

### **Rochester Electronics Manufactured Components**

Rochester branded components are manufactured using either die/wafers purchased from the original suppliers or Rochester wafers recreated from the original IP. All recreations are done with the approval of the OCM.

Parts are tested using original factory test programs or Rochester developed test solutions to guarantee product meets or exceed the OCM data sheet.

### **Quality Overview**

- ISO-9001
- AS9120 certification
- Qualified Manufacturers List (QML) MIL-PRF-35835
  - Class Q Military
  - Class V Space Level
- Qualified Suppliers List of Distributors (QSLD)
  - Rochester is a critical supplier to DLA and meets all industry and DLA standards.

Rochester Electronics, LLC is committed to supplying products that satisfy customer expectations for quality and are equal to those originally supplied by industry manufacturers.

---

The original manufacturer's datasheet accompanying this document reflects the performance and specifications of the Rochester manufactured version of this device. Rochester Electronics guarantees the performance of its semiconductor products to the original OEM specifications. 'Typical' values are for reference purposes only. Certain minimum or maximum ratings may be based on product characterization, design, simulation, or sample testing.

# SN54LS295B, SN74LS295B 4-BIT RIGHT-SHIFT LEFT-SHIFT REGISTERS WITH 3-STATE OUTPUTS

OCTOBER 1976 - REVISED MARCH 1988

- **'LS295B Offers Three Times the Sink-Current Capability of 'LS295A**
- **Schottky-Diode-Clamped Transistors**
- **Low Power Dissipation . . . 80 mW Typical (Enabled)**
- **Applications:**
  - N-Bit Serial-To-Parallel Converter**
  - N-Bit Parallel-To-Serial Converter**
  - N-Bit Storage Register**

## description

These 4-bit registers feature parallel inputs, parallel outputs, and clock (CLK), serial (SER), mode (LD/SH), and outputs control (OC) inputs. The registers have three modes of operation:

Parallel (broadside) load

Shift right (the direction  $Q_A$  toward  $Q_D$ )

Shift left (the direction  $Q_D$  toward  $Q_A$ )

Parallel loading is accomplished by applying the four bits of data and taking the mode control input high. The data is loaded into the associated flip-flops and appears at the outputs after the high-to-low transition of the clock input. During parallel loading, the entry of serial data is inhibited.

Shift right is accomplished when the mode control is low; shift left is accomplished when the mode control is high by connecting the output of each flip-flop to the parallel input of the previous flip-flop ( $Q_D$  to input C, etc.) and serial data is entered at input D.

When the output control is high, the normal logic levels of the four outputs are available for driving the loads or bus lines. The outputs are disabled independently from the level of the clock by a low logic level at the output control input. The outputs then present a high impedance and neither load nor drive the bus line; however, sequential operation of the registers is not affected.

The SN54LS295B is characterized for operation over the full military temperature range of  $-55^{\circ}\text{C}$  to  $125^{\circ}\text{C}$ ; the SN74LS295B is characterized for operation from  $0^{\circ}\text{C}$  to  $70^{\circ}\text{C}$ .

SN54LS295B . . . J OR W PACKAGE

SN74LS295B . . . D OR N PACKAGE

(TOP VIEW)

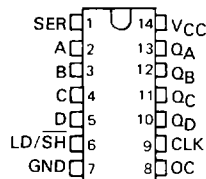

SN54LS295B . . . FK PACKAGE

(TOP VIEW)

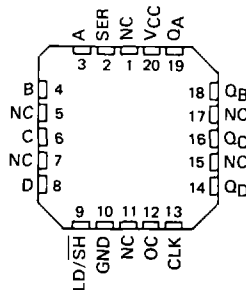

NC - N: internal connection

## logic symbol†

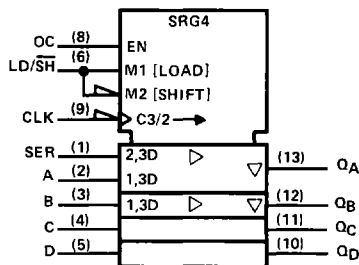

†This symbol is in accordance with ANSI/IEEE Std. 91-1984 and IEC Publication 617-12

Pin numbers shown are for D, J, N, and W packages.

2

TTL Devices

PRODUCTION DATA documents contain information current as of publication date. Products conform to specifications per the terms of Texas Instruments standard warranty. Production processing does not necessarily include testing of all parameters.

TEXAS  
INSTRUMENTS

POST OFFICE BOX 655012 • DALLAS, TEXAS 75265

2-807

# SN54LS295B, SN74LS295B 4-BIT RIGHT-SHIFT LEFT-SHIFT REGISTERS WITH 3-STATE OUTPUTS

logic diagram (positive logic)

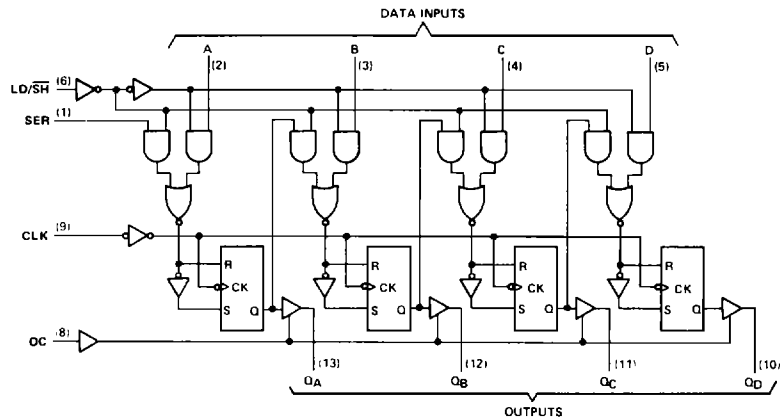

2

TTL Devices

Pin numbers shown are for D, J, N, and W packages

schematics of inputs and outputs

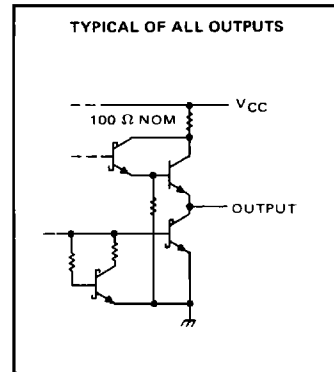
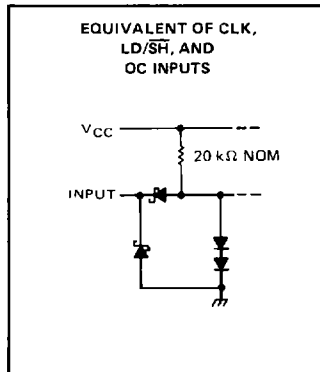
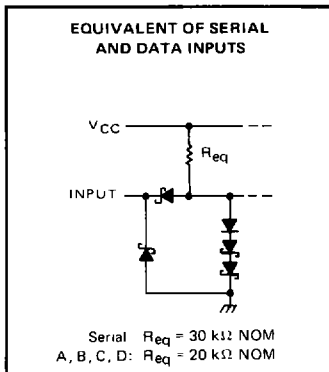

**SN54LS295B, SN74LS295B**  
**4-BIT RIGHT-SHIFT LEFT-SHIFT REGISTERS**  
**WITH 3-STATE OUTPUTS**

**FUNCTION TABLE**

INPUTS			PARALLEL				OUTPUTS			
LD/ $\overline{SH}$	CLK	SER	A	B	C	D	Q <sub>A</sub>	Q <sub>B</sub>	Q <sub>C</sub>	Q <sub>D</sub>
H	H	X	X	X	X	X	Q <sub>A0</sub>	Q <sub>B0</sub>	Q <sub>C0</sub>	Q <sub>D0</sub>
H	↓	X	a	b	c	d	a	b	c	d
H	↓	X	Q <sub>B</sub> <sup>†</sup>	Q <sub>C</sub> <sup>†</sup>	Q <sub>D</sub> <sup>†</sup>	d	Q <sub>Bn</sub>	Q <sub>Cn</sub>	Q <sub>Dn</sub>	d
L	H	X	X	X	X	X	Q <sub>A0</sub>	Q <sub>B0</sub>	Q <sub>C0</sub>	Q <sub>D0</sub>
L	↓	H	X	X	X	X	H	Q <sub>An</sub>	Q <sub>Bn</sub>	Q <sub>Cn</sub>
L	↓	L	X	X	X	X	L	Q <sub>An</sub>	Q <sub>Bn</sub>	Q <sub>Cn</sub>

When the output control is low, the outputs are disabled to the high-impedance state; however, sequential operation of the registers is not affected.

<sup>†</sup>Shifting left requires external connection of Q<sub>B</sub> to A, Q<sub>C</sub> to B, and Q<sub>D</sub> to C. Serial data is entered at input D.

H = high level (steady state), L = low level (steady state), X = irrelevant (any input, including transitions)  
 ↓ = transition from high to low level.

a, b, c, d = the level of steady state input at inputs A, B, C, or D, respectively.

Q<sub>A0</sub>, Q<sub>B0</sub>, Q<sub>C0</sub>, Q<sub>D0</sub> = the level of Q<sub>A</sub>, Q<sub>B</sub>, Q<sub>C</sub>, or Q<sub>D</sub>, respectively, before the indicated steady-state input conditions were established.

Q<sub>An</sub>, Q<sub>Bn</sub>, Q<sub>Cn</sub>, Q<sub>Dn</sub> = the level of Q<sub>A</sub>, Q<sub>B</sub>, Q<sub>C</sub>, or Q<sub>D</sub>, respectively, before the most-recent ↓ transition of the clock.

2

TTL Devices

**absolute maximum ratings over operating free-air temperature range (unless otherwise noted)**

Supply voltage, V <sub>CC</sub> (see Note 1)	7 V
Input voltage	7 V
Operating free-air temperature range: SN54LS295B	-55°C to 125°C
SN74LS295B	0°C to 70°C
Storage temperature range	-65°C to 150°C

NOTE 1. Voltage values are with respect to network ground terminal.

**recommended operating conditions**

		SN54LS295B			SN74LS295B			UNIT
		MIN	NOM	MAX	MIN	NOM	MAX	
V <sub>CC</sub>	Supply voltage	4.5	5	5.5	4.75	5	5.25	V
I <sub>OH</sub>	High-level output current			-1			-2.6	mA
I <sub>OL</sub>	Low-level output current			12			24	mA
f <sub>clock</sub>	Clock frequency	0		30	0		30	MHz
t <sub>w(clock)</sub>	Width of clock pulse	16			16			ns
t <sub>su</sub>	Setup time, high-level or low-level data	20			20			ns
t <sub>su</sub>	Setup time, LD/ $\overline{SH}$ to CLK	high-level	25		25			ns
		low-level	30		30			
t <sub>h</sub>	Hold time, high-level or low-level data	20			20			ns
t <sub>h</sub>	Hold time, high-level or low-level LD/ $\overline{SH}$ to CLK	0			0			ns
T <sub>A</sub>	Operating free-air temperature	-55		125	0		70	°C

# SN54LS295B, SN74LS295B

## 4-BIT RIGHT-SHIFT LEFT-SHIFT REGISTERS WITH 3-STATE OUTPUTS

electrical characteristics over recommended operating free-air temperature range (unless otherwise noted)

PARAMETER	TEST CONDITIONS†	SN54LS295B			SN74LS295B			UNIT
		MIN	TYP‡	MAX	MIN	TYP‡	MAX	
V <sub>IH</sub> High-level input voltage		2			2			V
V <sub>IL</sub> Low-level input voltage		0.7			0.8			V
V <sub>IK</sub> Input clamp voltage	V <sub>CC</sub> = MIN, I <sub>I</sub> = -18 mA	-1.5			-1.5			V
V <sub>OH</sub> High-level output voltage	V <sub>CC</sub> = MIN, V <sub>IH</sub> = 2 V, V <sub>IL</sub> = V <sub>IL</sub> max, I <sub>OH</sub> = MAX	2.4	3.4		2.4	3.1		V
V <sub>OL</sub> Low-level output voltage	V <sub>CC</sub> = MIN, V <sub>IH</sub> = 2 V, V <sub>IL</sub> = V <sub>IL</sub> max	I <sub>OL</sub> = 12 mA		0.25	0.4	I <sub>OL</sub> = 24 mA		V
I <sub>OZH</sub> Off-state output current, high-level voltage applied	V <sub>CC</sub> = MAX, V <sub>IH</sub> = V <sub>IH</sub> max, V <sub>O</sub> = 2.7 V	20			20			μA
I <sub>OZL</sub> Off-state output current, low-level voltage applied	V <sub>CC</sub> = MAX, V <sub>IH</sub> = 2 V, V <sub>O</sub> = 0.4 V	-20			-20			μA
I <sub>I</sub> Input current at maximum input voltage	V <sub>CC</sub> = MAX, V <sub>I</sub> = 7 V	0.1			0.1			mA
I <sub>IH</sub> High-level input current	V <sub>CC</sub> = MAX, V <sub>I</sub> = 2.7 V	20			20			μA
I <sub>IL</sub> Low-level input current	V <sub>CC</sub> = MAX, V <sub>I</sub> = 0.4 V	-0.4			-0.4			mA
I <sub>OS</sub> Short-circuit output current§	V <sub>CC</sub> = MAX	-30	-130		-30	-130		mA
I <sub>CC</sub> Supply current	V <sub>CC</sub> = MAX, See Note 2	Condition A		20	29	Condition B		mA
		Condition B		22	33	22 33		

† For conditions shown as MIN or MAX, use the appropriate value specified under recommended operating conditions.

‡ All typical values are at V<sub>CC</sub> = 5 V, T<sub>A</sub> = 25° C.

§ Not more than one output should be shorted at a time and duration of the short-circuit should not exceed one second.

NOTE 2. I<sub>CC</sub> is measured with the outputs open, the serial input and mode control at 4.5 V, and the data inputs grounded under the following conditions.

- Output control at 4.5 V and a momentary 3 V, then ground, applied to clock input.
- Output control and clock input grounded.

switching characteristics, V<sub>CC</sub> = 5 V, T<sub>A</sub> = 25° C, R<sub>L</sub> = 667 Ω

PARAMETER	TEST CONDITIONS	MIN	TYP	MAX	UNIT
f <sub>max</sub> Maximum clock frequency		30	45		MHz
t <sub>PLH</sub> Propagation delay time, low-to-high-level output	C <sub>L</sub> = 45 pF, See Note 3	14		20	ns
t <sub>PHL</sub> Propagation delay time, high-to-low-level output		19		30	ns
t <sub>PZH</sub> Output enable time to high level		18		26	ns
t <sub>PZL</sub> Output enable time to low level		20		30	ns
t <sub>PHZ</sub> Output disable time from high level	C <sub>L</sub> = 5 pF, See Note 3	13		20	ns
t <sub>PLZ</sub> Output disable time from low level		13		20	ns

NOTE 3: Load circuits and voltage waveforms are shown in Section 1

2

TTL Devices