



# M74HC165

## 8 BIT PISO SHIFT REGISTER

- HIGH SPEED :  
 $t_{PD} = 15\text{ns}$  (TYP.) at  $V_{CC} = 6\text{V}$
- LOW POWER DISSIPATION:  
 $I_{CC} = 4\mu\text{A}$ (MAX.) at  $T_A = 25^\circ\text{C}$
- HIGH NOISE IMMUNITY:  
 $V_{NIH} = V_{NIL} = 28\% V_{CC}$  (MIN.)
- SYMMETRICAL OUTPUT IMPEDANCE:  
 $|I_{OH}| = I_{OL} = 4\text{mA}$  (MIN)
- BALANCED PROPAGATION DELAYS:  
 $t_{PLH} \approx t_{PHL}$
- WIDE OPERATING VOLTAGE RANGE:  
 $V_{CC}$  (OPR) = 2V to 6V
- PIN AND FUNCTION COMPATIBLE WITH  
 74 SERIES 165



### ORDER CODES

PACKAGE	TUBE	T & R
DIP	M74HC165B1R	
SOP	M74HC165M1R	M74HC165RM13TR
TSSOP		M74HC165TTR

### DESCRIPTION

The M74HC165 is an high speed CMOS 8 BIT PISO SHIFT REGISTER fabricated with silicon gate C<sup>2</sup>MOS technology. This device contains eight clocked master slave RS flip-flops connected as a shift register, with auxiliary gating to provide over-riding asynchronous parallel entry. Parallel data enters when the shift/load input is low. The parallel data can change while shift/load is low, provided that the recommended set-up and hold times are observed. For clocked operation, shift/load must

be high. The two clock input perform identically; one can be used as a clock inhibit by applying a high signal; to permit this operation clocking is accomplished through a 2 input nor gate. To avoid double clocking, however, the inhibit signal should only go high while the clock is high. Otherwise the rising inhibit signal will cause the same response as rising clock edge. All inputs are equipped with protection circuits against static discharge and transient excess voltage.

### PIN CONNECTION AND IEC LOGIC SYMBOLS

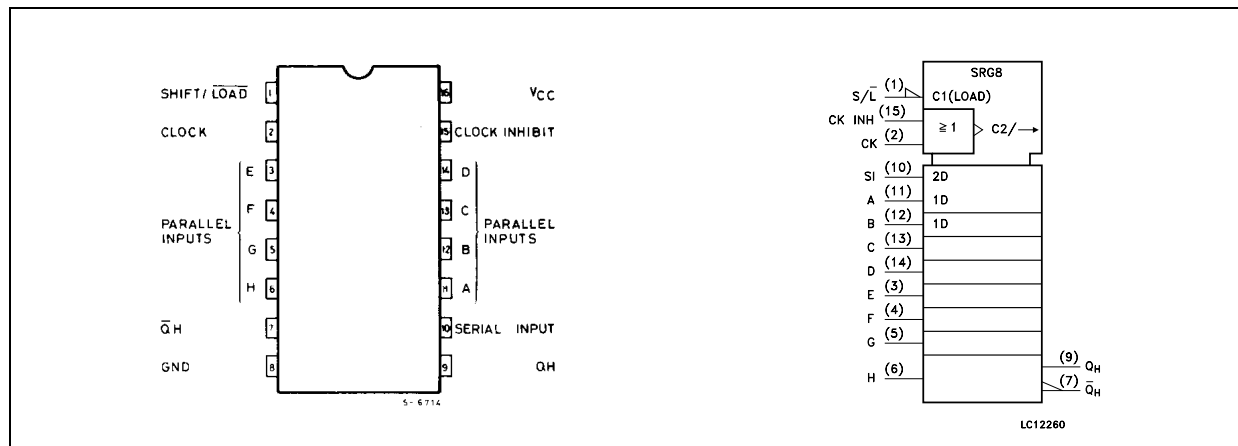

INPUT AND OUTPUT EQUIVALENT CIRCUIT

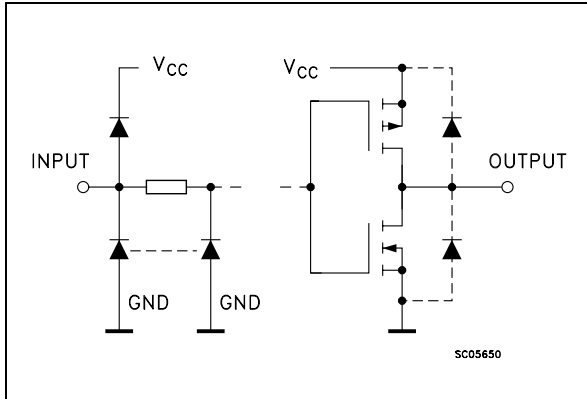

PIN DESCRIPTION

PIN No	SYMBOL	NAME AND FUNCTION
1	SHIFT/LOAD	Data Inputs
2	$\overline{QH}$	Complementary Output
7	QH	Serial Output
9	CLOCK	Clock Input (LOW to HIGH, Edge Triggered)
10	SI	Serial Data Inputs
11, 12, 13, 14, 3, 4, 5, 6	A to H	Parallel Data Inputs
15	CLOCK INH	Clock Inhibit
8	GND	Ground (0V)
16	Vcc	Positive Supply Voltage

TRUTH TABLE

INPUTS					INTERNAL OUTPUTS		OUTPUTS
SHIFT/LOAD	CLOCK INH	CLOCK	SI	A.....H	QA	QB	QH
L	X	X	X	a.....h	a	b	h
H	L		H	X	H	QAn	QGn
H	L		L	X	L	QAn	QGn
H		L	H	X	H	QAn	QGn
H		L	L	X	L	QAn	QGn
H	X	H	X	X	NO CHANGE		
H	H	X	X	X	NO CHANGE		

a.....h : The level of steady input voltage at inputs a through respectively  
 QAn - QGn : The level of QA - QG, respectively, before the most-recent transition of the clock

LOGIC DIAGRAM

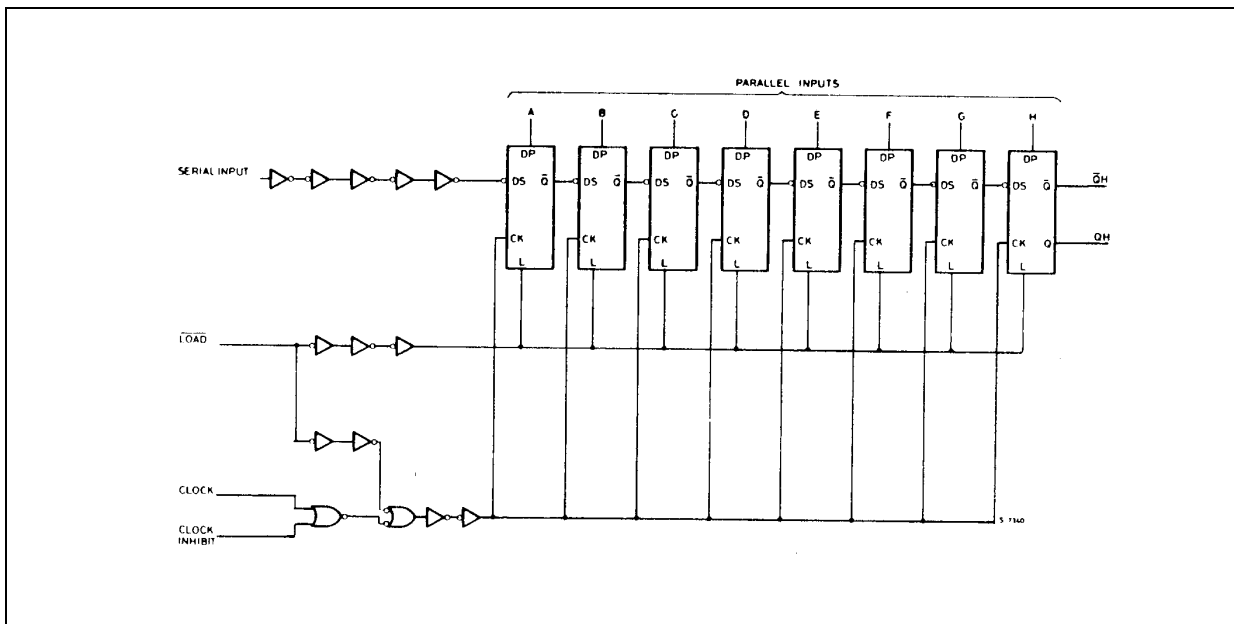

## TIMING CHART

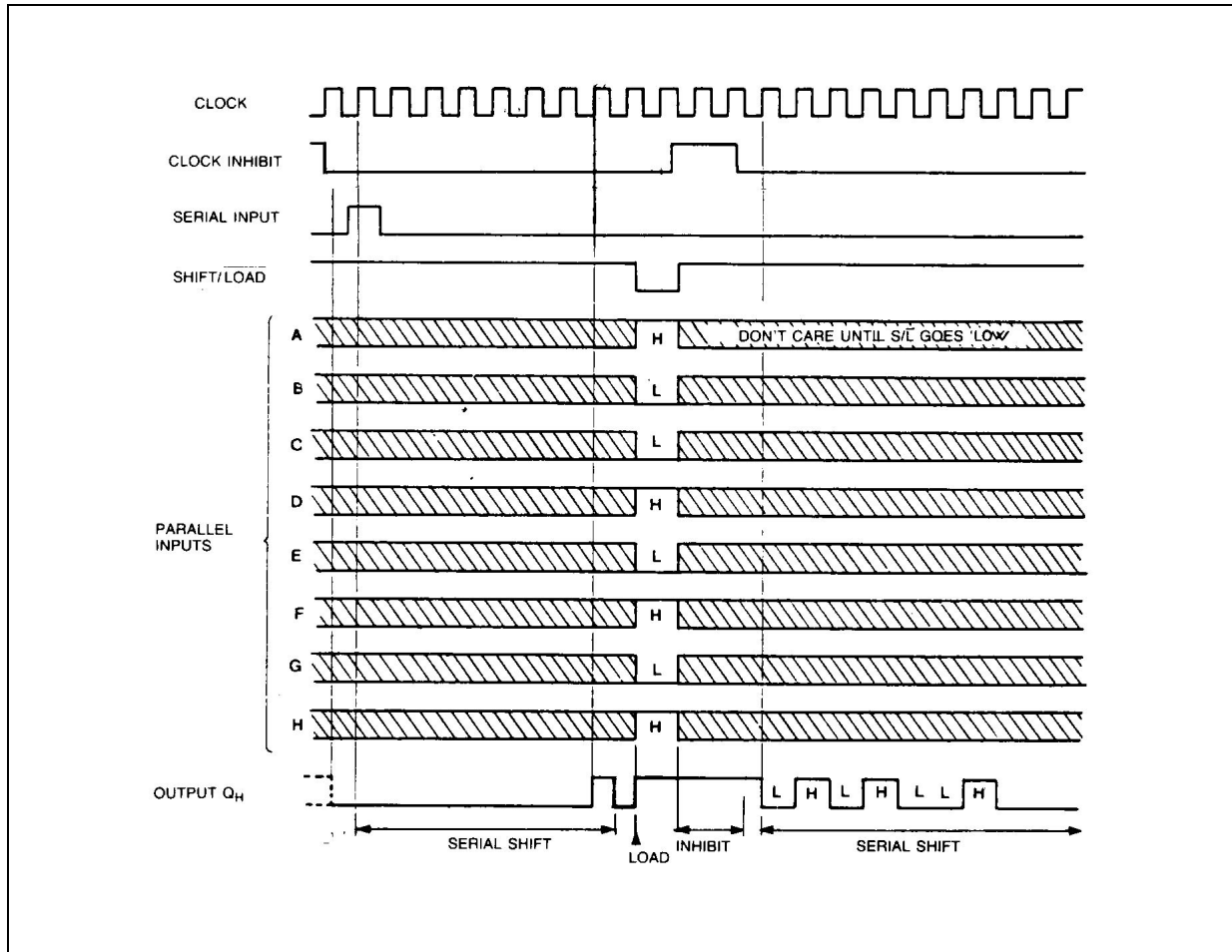

## ABSOLUTE MAXIMUM RATINGS

Symbol	Parameter	Value	Unit
$V_{CC}$	Supply Voltage	-0.5 to +7	V
$V_I$	DC Input Voltage	-0.5 to $V_{CC} + 0.5$	V
$V_O$	DC Output Voltage	-0.5 to $V_{CC} + 0.5$	V
$I_{IK}$	DC Input Diode Current	$\pm 20$	mA
$I_{OK}$	DC Output Diode Current	$\pm 20$	mA
$I_O$	DC Output Current	$\pm 25$	mA
$I_{CC}$ or $I_{GND}$	DC $V_{CC}$ or Ground Current	$\pm 50$	mA
$P_D$	Power Dissipation	500(*)	mW
$T_{stg}$	Storage Temperature	-65 to +150	$^{\circ}C$
$T_L$	Lead Temperature (10 sec)	300	$^{\circ}C$

Absolute Maximum Ratings are those values beyond which damage to the device may occur. Functional operation under these conditions is not implied.

(\*) 500mW at 65  $^{\circ}C$ ; derate to 300mW by 10mW/ $^{\circ}C$  from 65 $^{\circ}C$  to 85 $^{\circ}C$

## RECOMMENDED OPERATING CONDITIONS

Symbol	Parameter	Value	Unit	
$V_{CC}$	Supply Voltage	2 to 6	V	
$V_I$	Input Voltage	0 to $V_{CC}$	V	
$V_O$	Output Voltage	0 to $V_{CC}$	V	
$T_{op}$	Operating Temperature	-55 to 125	°C	
$t_r, t_f$	Input Rise and Fall Time	$V_{CC} = 2.0V$	0 to 1000	ns
		$V_{CC} = 4.5V$	0 to 500	ns
		$V_{CC} = 6.0V$	0 to 400	ns

## DC SPECIFICATIONS

Symbol	Parameter	Test Condition		Value						Unit	
		$V_{CC}$ (V)		$T_A = 25^\circ C$			$-40 \text{ to } 85^\circ C$		$-55 \text{ to } 125^\circ C$		
				Min.	Typ.	Max.	Min.	Max.	Min.		Max.
$V_{IH}$	High Level Input Voltage	2.0		1.5			1.5		1.5		V
		4.5		3.15			3.15		3.15		
		6.0		4.2			4.2		4.2		
$V_{IL}$	Low Level Input Voltage	2.0				0.5		0.5		0.5	V
		4.5				1.35		1.35		1.35	
		6.0				1.8		1.8		1.8	
$V_{OH}$	High Level Output Voltage	2.0	$I_O = -20 \mu A$	1.9	2.0		1.9		1.9		V
		4.5	$I_O = -20 \mu A$	4.4	4.5		4.4		4.4		
		6.0	$I_O = -20 \mu A$	5.9	6.0		5.9		5.9		
		4.5	$I_O = -4.0 \text{ mA}$	4.18	4.31		4.13		4.10		
		6.0	$I_O = -5.2 \text{ mA}$	5.68	5.8		5.63		5.60		
$V_{OL}$	Low Level Output Voltage	2.0	$I_O = 20 \mu A$		0.0	0.1		0.1		0.1	V
		4.5	$I_O = 20 \mu A$		0.0	0.1		0.1		0.1	
		6.0	$I_O = 20 \mu A$		0.0	0.1		0.1		0.1	
		4.5	$I_O = 4.0 \text{ mA}$		0.17	0.26		0.33		0.40	
		6.0	$I_O = 5.2 \text{ mA}$		0.18	0.26		0.33		0.40	
$I_I$	Input Leakage Current	6.0	$V_I = V_{CC} \text{ or GND}$			$\pm 0.1$		$\pm 1$		$\pm 1$	$\mu A$
$I_{CC}$	Quiescent Supply Current	6.0	$V_I = V_{CC} \text{ or GND}$			4		40		80	$\mu A$

AC ELECTRICAL CHARACTERISTICS ( $C_L = 50 \text{ pF}$ , Input  $t_r = t_f = 6 \text{ ns}$ )

Symbol	Parameter	Test Condition		Value						Unit	
		$V_{CC}$ (V)		$T_A = 25^\circ\text{C}$			$-40 \text{ to } 85^\circ\text{C}$		$-55 \text{ to } 125^\circ\text{C}$		
				Min.	Typ.	Max.	Min.	Max.	Min.		Max.
$t_{TLH}$ $t_{THL}$	Output Transition Time	2.0			30	75		95		110	ns
		4.5			8	15		19		22	
		6.0			7	13		16		19	
$t_{PLH}$ $t_{PHL}$	Propagation Delay Time (CLOCK - QH, $\overline{QH}$ )	2.0			55	150		190		225	ns
		4.5			18	30		38		45	
		6.0			15	26		33		38	
$t_{PLH}$ $t_{PHL}$	Propagation Delay Time (SHIFT/LOAD - QH, $\overline{QH}$ )	2.0			65	165		205	250		ns
		4.5			21	33		41		50	
		6.0			18	28		35		43	
$t_{PLH}$ $t_{PHL}$	Propagation Delay Time (H - QH, $\overline{QH}$ )	2.0			52	135		170		205	ns
		4.5			17	27		34		41	
		6.0			14	23		29		35	
$f_{MAX}$	Maximum Clock Frequency	2.0		7.4	15		6.0		4.8		MHz
		4.5		37	60		30		24		
		6.0		44	71		35		28		
$t_{W(H)}$ $t_{W(L)}$	Minimum Pulse Width (CLOCK)	2.0			24	75		95		110	ns
		4.5			6	15		19		22	
		6.0			5	13		16		19	
$t_{W(L)}$	Minimum Pulse Width (SHIFT/LOAD)	2.0			32	75		95		110	ns
		4.5			8	15		19		22	
		6.0			7	13		16		19	
$t_s$	Minimum Set-up Time (PI - SHIFT/LOAD) (SI - CLOCK) (SHIFT/LOAD - CK)	2.0			24	75		95		110	ns
		4.5			6	15		19		22	
		6.0			5	13		16		19	
$t_h$	Minimum Hold Time (PI - SHIFT/LOAD) (SI - CLOCK) (SHIFT/LOAD - CK)	2.0				0		0		0	ns
		4.5				0		0		0	
		6.0				0		0		0	
$t_{REM}$	Minimum Removal Time (CLOCK - CK INH)	2.0			20	75		95		110	ns
		4.5			5	15		19		22	
		6.0			4	13		16		19	

## CAPACITIVE CHARACTERISTICS

Symbol	Parameter	Test Condition		Value						Unit	
		$V_{CC}$ (V)		$T_A = 25^\circ\text{C}$			$-40 \text{ to } 85^\circ\text{C}$		$-55 \text{ to } 125^\circ\text{C}$		
				Min.	Typ.	Max.	Min.	Max.	Min.		Max.
$C_{IN}$	Input Capacitance	5.0			5	10		10		10	pF
$C_{PD}$	Power Dissipation Capacitance (note 1)	5.0			55						pF

1)  $C_{PD}$  is defined as the value of the IC's internal equivalent capacitance which is calculated from the operating current consumption without load. (Refer to Test Circuit). Average operating current can be obtained by the following equation.  $I_{CC(oper)} = C_{PD} \times V_{CC} \times f_{IN} + I_{CC}$

TEST CIRCUIT

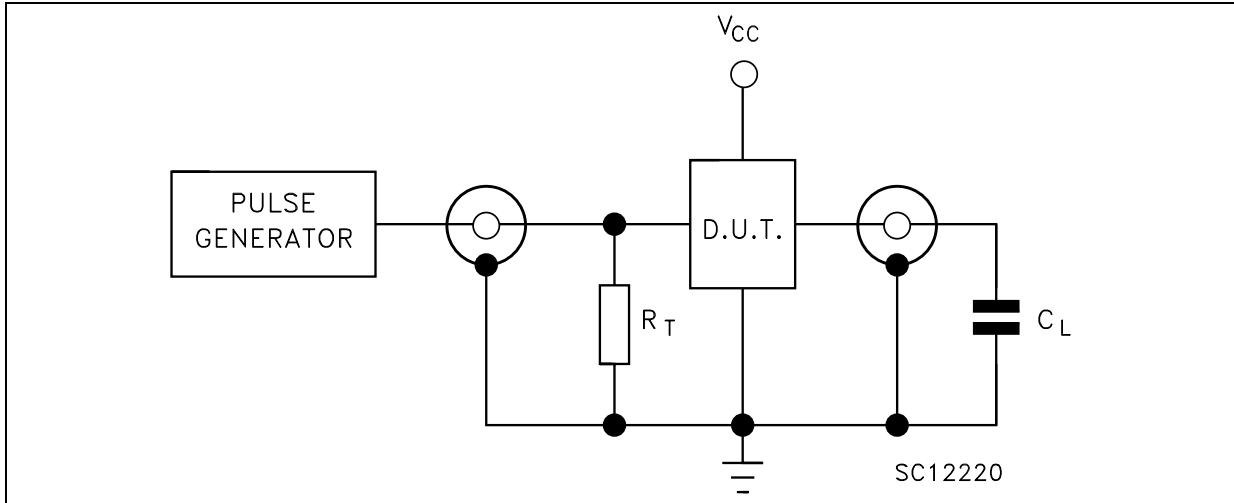

$C_L = 50\text{pF}$  or equivalent (includes jig and probe capacitance)  
 $R_T = Z_{OUT}$  of pulse generator (typically  $50\Omega$ )

WAVEFORM 1: SERIAL MODE PROPAGATION DELAY ( $f=1\text{MHz}$ ; 50% duty cycle)

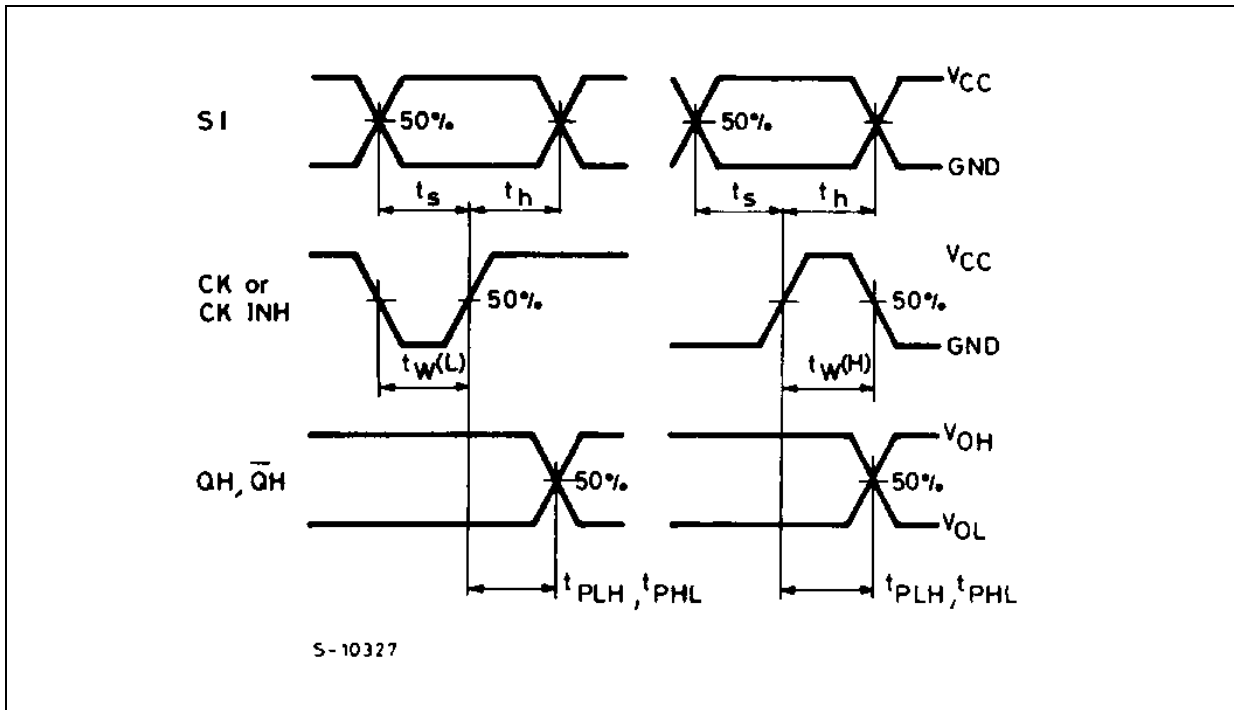

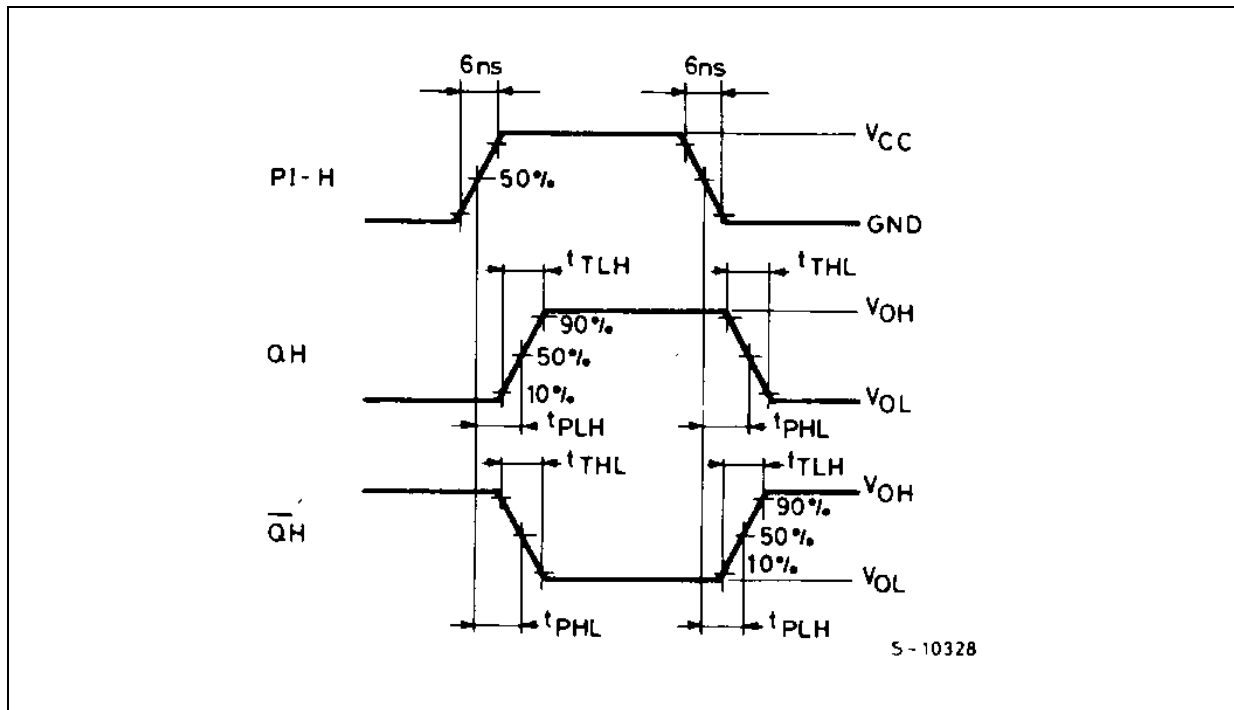
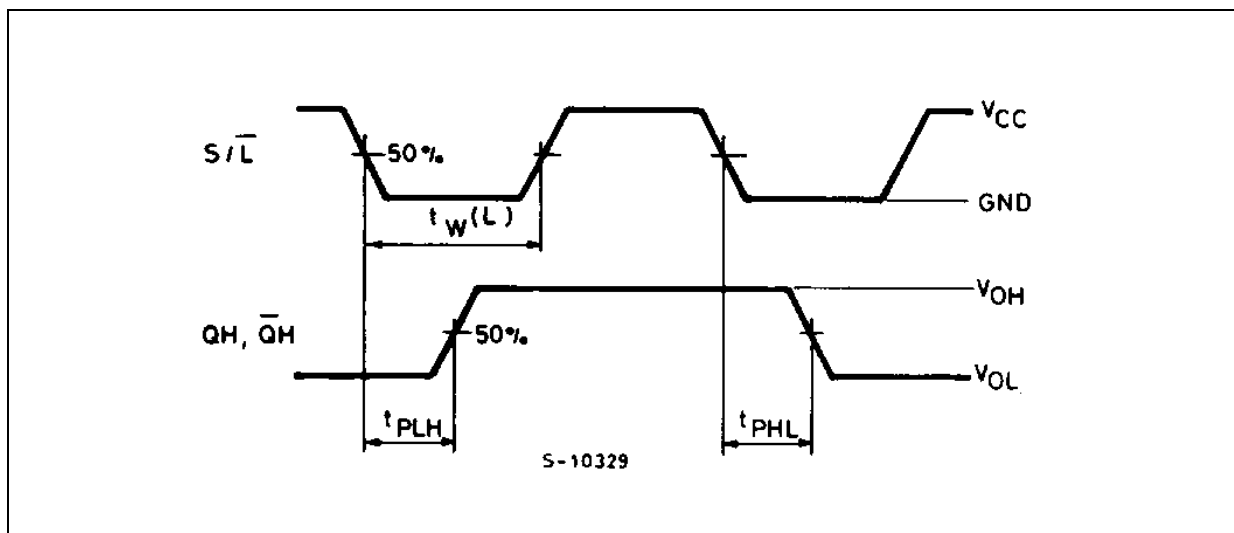
**WAVEFORM 2: PARALLEL MODE PROPAGATION DELAY** ( $f=1\text{MHz}$ ; 50% duty cycle)**WAVEFORM 3: MINIMUM PULSE WIDTH ( $S/\overline{L}$ ), PROPAGATION DELAY TIMES**  
( $f=1\text{MHz}$ ; 50% duty cycle)

WAVEFORM 4: SETUP AND HOLD TIME (PI TO S/L) (f=1MHz; 50% duty cycle)

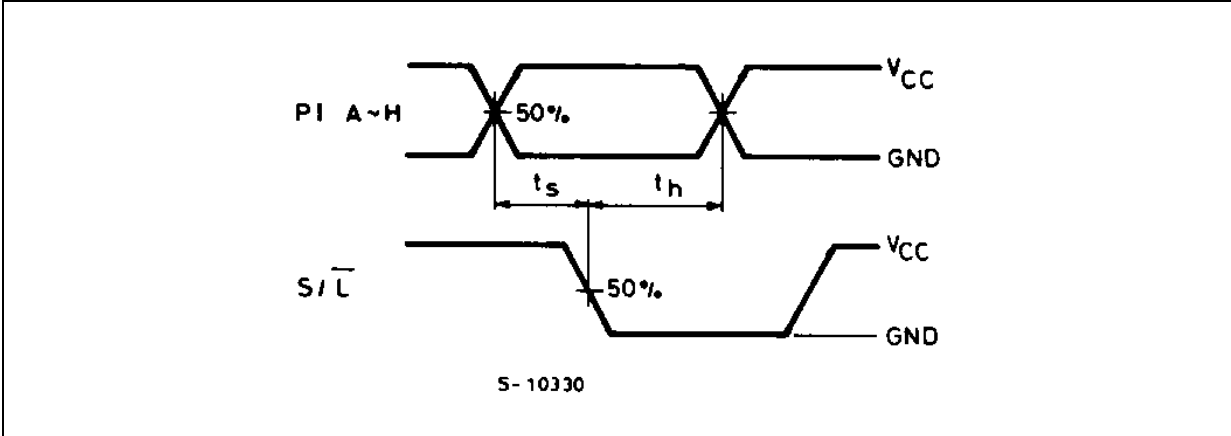

WAVEFORM 5: MINIMUM REMOVAL TIME (CK INH TO CK) (f=1MHz; 50% duty cycle)

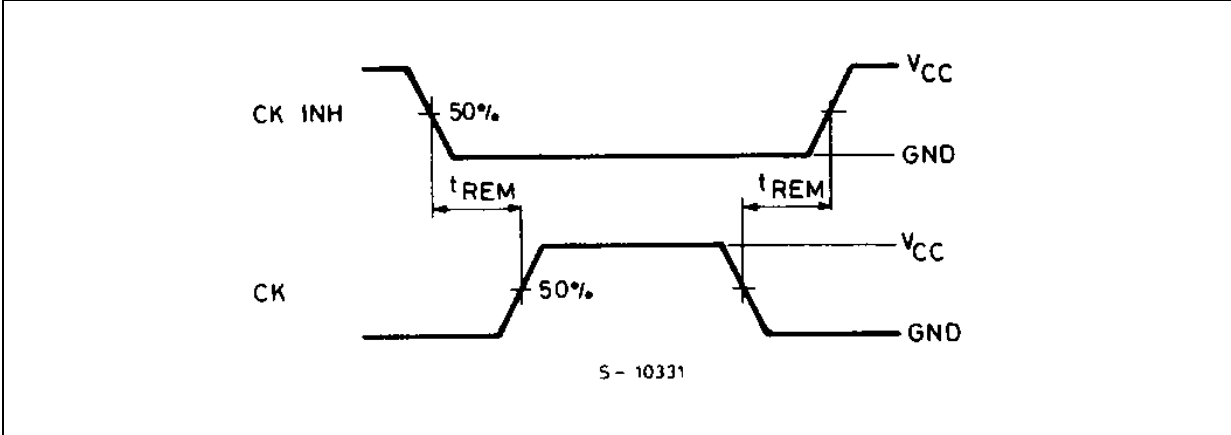



### Plastic DIP-16 (0.25) MECHANICAL DATA

DIM.	mm.			inch		
	MIN.	TYP	MAX.	MIN.	TYP.	MAX.
a1	0.51			0.020		
B	0.77		1.65	0.030		0.065
b		0.5			0.020	
b1		0.25			0.010	
D			20			0.787
E		8.5			0.335	
e		2.54			0.100	
e3		17.78			0.700	
F			7.1			0.280
I			5.1			0.201
L		3.3			0.130	
Z			1.27			0.050



**SO-16 MECHANICAL DATA**

DIM.	mm.			inch		
	MIN.	TYP.	MAX.	MIN.	TYP.	MAX.
A			1.75			0.068
a1	0.1		0.2	0.003		0.007
a2			1.65			0.064
b	0.35		0.46	0.013		0.018
b1	0.19		0.25	0.007		0.010
C		0.5			0.019	
c1	45° (typ.)					
D	9.8		10	0.385		0.393
E	5.8		6.2	0.228		0.244
e		1.27			0.050	
e3		8.89			0.350	
F	3.8		4.0	0.149		0.157
G	4.6		5.3	0.181		0.208
L	0.5		1.27	0.019		0.050
M			0.62			0.024
S	8° (max.)					



PO13H

## TSSOP16 MECHANICAL DATA

DIM.	mm.			inch		
	MIN.	TYP.	MAX.	MIN.	TYP.	MAX.
A			1.2			0.047
A1	0.05		0.15	0.002	0.004	0.006
A2	0.8	1	1.05	0.031	0.039	0.041
b	0.19		0.30	0.007		0.012
c	0.09		0.20	0.004		0.0089
D	4.9	5	5.1	0.193	0.197	0.201
E	6.2	6.4	6.6	0.244	0.252	0.260
E1	4.3	4.4	4.48	0.169	0.173	0.176
e		0.65 BSC			0.0256 BSC	
K	0°		8°	0°		8°
L	0.45	0.60	0.75	0.018	0.024	0.030



Information furnished is believed to be accurate and reliable. However, STMicroelectronics assumes no responsibility for the consequences of use of such information nor for any infringement of patents or other rights of third parties which may result from its use. No license is granted by implication or otherwise under any patent or patent rights of STMicroelectronics. Specifications mentioned in this publication are subject to change without notice. This publication supersedes and replaces all information previously supplied. STMicroelectronics products are not authorized for use as critical components in life support devices or systems without express written approval of STMicroelectronics.

© The ST logo is a registered trademark of STMicroelectronics

© 2001 STMicroelectronics - Printed in Italy - All Rights Reserved  
STMicroelectronics GROUP OF COMPANIES

Australia - Brazil - China - Finland - France - Germany - Hong Kong - India - Italy - Japan - Malaysia - Malta - Morocco  
Singapore - Spain - Sweden - Switzerland - United Kingdom

© <http://www.st.com>