

## FST16212 24-Bit Bus Exchange Switch

### General Description

The Fairchild Switch FST16212 provides 24-bits of high-speed CMOS TTL-compatible bus switching or exchanging. The low on resistance of the switch allows inputs to be connected to outputs without adding propagation delay or generating additional ground bounce noise.

The device operates as a 24-bit bus switch or a 12-bit bus exchanger, which allows data exchange between the four signal ports via the data-select terminals.

### Features

- 4Ω switch connection between two ports.
- Minimal propagation delay through the switch.
- Low I<sub>CC</sub>.
- Zero bounce in flow-through mode.
- Control inputs compatible with TTL level.

### Ordering Code:

Order Number	Package Number	Package Description
FST16212MEA	MS56A	56-Lead Shrink Small Outline Package (SSOP), JEDEC MO-118, 0.300" Wide
FST16212MTD	MTD56	56-Lead Thin Shrink Small Outline Package (TSSOP), JEDEC MO-153, 6.1mm Wide

Devices also available in Tape and Reel. Specify by appending the suffix letter "X" to the ordering code.

### Logic Diagram

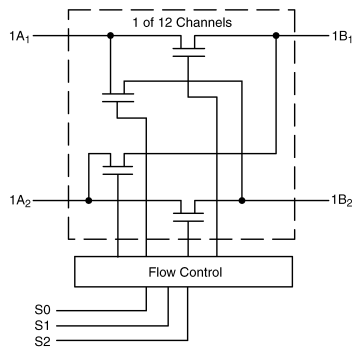

### Connection Diagram

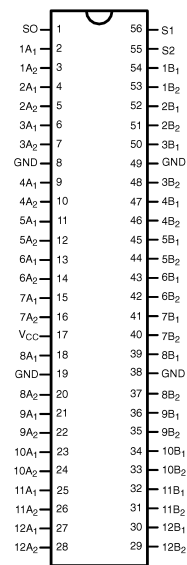

### Truth Table

S2	S1	S0	A <sub>1</sub>	A <sub>2</sub>	Function
L	L	L	Z	Z	Disconnect
L	L	H	B <sub>1</sub>	Z	A <sub>1</sub> = B <sub>1</sub>
L	H	L	B <sub>2</sub>	Z	A <sub>1</sub> = B <sub>2</sub>
L	H	H	Z	B <sub>1</sub>	A <sub>2</sub> = B <sub>1</sub>
H	L	L	Z	B <sub>2</sub>	A <sub>2</sub> = B <sub>2</sub>
H	L	H	Z	Z	Disconnect
H	H	L	B <sub>1</sub>	B <sub>2</sub>	A <sub>1</sub> = B <sub>1</sub> , A <sub>2</sub> = B <sub>2</sub>
H	H	H	B <sub>2</sub>	B <sub>1</sub>	A <sub>1</sub> = B <sub>2</sub> , A <sub>2</sub> = B <sub>1</sub>

### Pin Descriptions

Pin Name	Description
S2, S1, S0	Data-select inputs
A <sub>1</sub> , A <sub>2</sub>	Bus A
B <sub>1</sub> , B <sub>2</sub>	Bus B

**Absolute Maximum Ratings** (Note 1)

Supply Voltage ( $V_{CC}$ )	-0.5V to +7.0V
DC Switch Voltage ( $V_S$ )	-0.5V to +7.0V
DC Input Voltage ( $V_{IN}$ ) (Note 2)	-0.5V to +7.0V
DC Input Diode Current ( $I_{IK}$ ) $V_{IN} < 0V$	-50mA
DC Output ( $I_{OUT}$ ) Sink Current	128mA
DC $V_{CC}$ /GND Current ( $I_{CC}/I_{GND}$ )	+/- 100mA
Storage Temperature Range ( $T_{STG}$ )	-65°C to +150 °C

**Recommended Operating Conditions** (Note 3)

Power Supply Operating ( $V_{CC}$ )	4.0V to 5.5V
Input Voltage ( $V_{IN}$ )	0V to 5.5V
Output Voltage ( $V_{OUT}$ )	0V to 5.5V
Input Rise and Fall Time ( $t_r, t_f$ )	
Switch Control Input	0nS/V to 5nS/V
Switch I/O	0nS/V to DC
Free Air Operating Temperature ( $T_A$ )	-40 °C to +85 °C

**Note 1:** The "Absolute Maximum Ratings" are those values beyond which the safety of the device cannot be guaranteed. The device should not be operated at these limits. The parametric values defined in the Electrical Characteristics tables are not guaranteed at the absolute maximum rating. The "Recommended Operating Conditions" table will define the conditions for actual device operation.

**Note 2:** The input and output negative voltage ratings may be exceeded if the input and output diode current ratings are observed.

**Note 3:** Unused control inputs must be held high or low. They may not float.

**DC Electrical Characteristics**

Symbol	Parameter	$V_{CC}$ (V)	$T_A = -40\text{ °C to }+85\text{ °C}$			Units	Conditions
			Min	Typ (Note 4)	Max		
$V_{IK}$	Clamp Diode Voltage	4.5			-1.2	V	$I_{IN} = -18\text{mA}$
$V_{IH}$	HIGH Level Input Voltage	4.0-5.5	2.0			V	
$V_{IL}$	LOW Level Input Voltage	4.0-5.5			0.8	V	
$I_I$	Input Leakage Current	5.5			$\pm 1.0$	$\mu\text{A}$	$0 \leq V_{IN} \leq 5.5\text{V}$
		0			10	$\mu\text{A}$	$V_{IN} = 5.5\text{V}$
$I_{OZ}$	OFF-STATE Leakage Current	5.5			$\pm 1.0$	$\mu\text{A}$	$0 \leq A, B \leq V_{CC}$
$R_{ON}$	Switch On Resistance (Note 5)	4.5		4	7	$\Omega$	$V_{IN} = 0\text{V}, I_{IN} = 64\text{mA}$
		4.5		4	7	$\Omega$	$V_{IN} = 0\text{V}, I_{IN} = 30\text{mA}$
		4.5		8	12	$\Omega$	$V_{IN} = 2.4\text{V}, I_{IN} = 15\text{mA}$
		4.0		14	20	$\Omega$	$V_{IN} = 2.4\text{V}, I_{IN} = 15\text{mA}$
$I_{CC}$	Quiescent Supply Current	5.5			3	$\mu\text{A}$	$V_{IN} = V_{CC}$ or GND, $I_{OUT} = 0$
$\Delta I_{CC}$	Increase in $I_{CC}$ per Input	5.5			2.5	mA	One input at 3.4V Other inputs at $V_{CC}$ or GND

**Note 4:** Typical values are at  $V_{CC} = 5.0\text{V}$  and  $T_A = +25\text{ °C}$

**Note 5:** Measured by the voltage drop between A and B pins at the indicated current through the switch. On resistance is determined by the lower of the voltages on the two (A or B) pins.

## AC Electrical Characteristics

Symbol	Parameter	T <sub>A</sub> = -40 °C to +85 °C, C <sub>L</sub> = 50pF, R <sub>U</sub> = R <sub>D</sub> = 500Ω				Units	Conditions	Figure No.
		V <sub>CC</sub> = 4.5 – 5.5V		V <sub>CC</sub> = 4.0V				
		Min	Max	Min	Max			
t <sub>PHL</sub> , t <sub>PLH</sub>	Prop Delay Bus to Bus (Note 6)		0.25		0.25	ns	V <sub>I</sub> = OPEN	Figures 1, 2
t <sub>PHL</sub> , t <sub>PLH</sub>	Prop Delay S to Bus	1.5	7.0		7.5	ns	V <sub>I</sub> = OPEN	Figures 1, 2
t <sub>PZH</sub> , t <sub>PZL</sub>	Output Enable Time, S to A or B	1.5	7.5		8.0	ns	V <sub>I</sub> = 7V for t <sub>PZL</sub> V <sub>I</sub> = OPEN for t <sub>PZH</sub>	Figures 1, 2
t <sub>PHZ</sub> , t <sub>PLZ</sub>	Output Disable Time S to A or B	1.0	8.5		9.0	ns	V <sub>I</sub> = 7V for t <sub>PLZ</sub> V <sub>I</sub> = OPEN for t <sub>PHZ</sub>	Figures 1, 2
BW	-3dB Bandwidth	250				MHz	R <sub>L</sub> = 50Ω	

**Note 6:** This parameter is guaranteed by design but is not tested. The bus switch contributes no propagation delay other than the RC delay of the typical On resistance of the switch and the 50pF load capacitance, when driven by an ideal voltage source (zero output impedance).

## Capacitance (Note 7)

Symbol	Parameter	Typ	Max	Units	Conditions
C <sub>IN</sub>	Control pin Input Capacitance	3		pF	V <sub>CC</sub> = 5.0V
C <sub>I/O</sub>	Input/Output Capacitance	10		pF	V <sub>CC</sub> = 5.0V, S0, S1, or S2 = GND

**Note 7:** T<sub>A</sub> = +25°C, f = 1 MHz, Capacitance is characterized but not tested.

## AC Loading and Waveforms

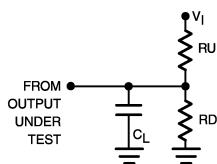

Note: Input driven by 50 Ω source terminated in 50 Ω

Note: C<sub>L</sub> includes load and stray capacitance

Note Input PRR = 1.0 MHz, t<sub>W</sub> = 500 ns

FIGURE 1. AC Test Circuit

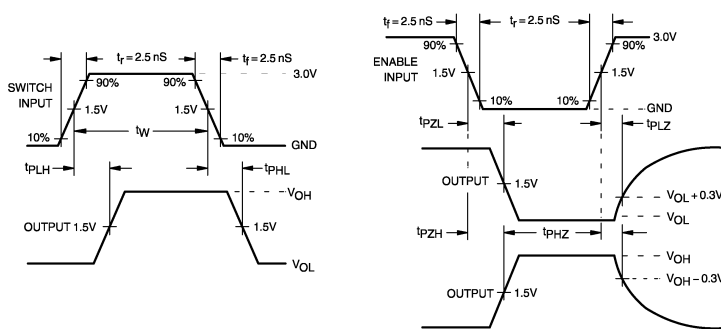
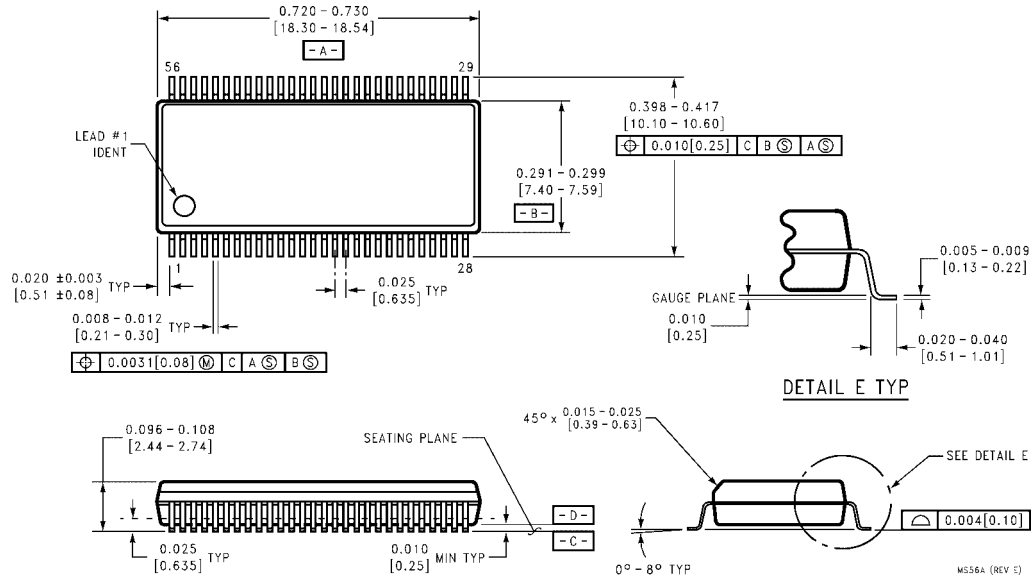

FIGURE 2. AC Waveforms

**Physical Dimensions** inches (millimeters) unless otherwise noted



**56-Lead Shrink Small Outline Package (SSOP), JEDEC MO-118, 0.300" Wide  
Package Number MS56A**

MS56A (REV 1)

**Physical Dimensions** inches (millimeters) unless otherwise noted (Continued)

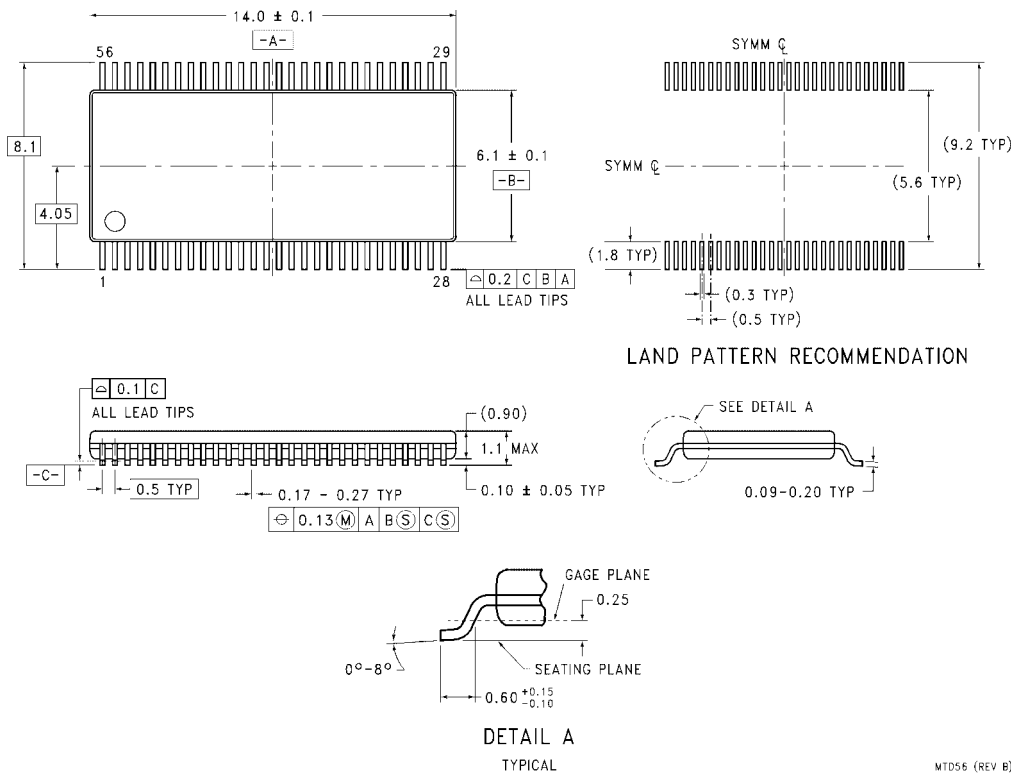

**56-Lead Thin Shrink Small Outline Package (TSSOP), JEDEC MO-153, 6.1mm Wide  
Package Number MTD56**

**Technology Description**

The Fairchild Switch family derives from and embodies Fairchild's proven switch technology used for several years in its 74LVX3L384 (FST3384) bus switch product.

Fairchild does not assume any responsibility for use of any circuitry described, no circuit patent licenses are implied and Fairchild reserves the right at any time without notice to change said circuitry and specifications.

**LIFE SUPPORT POLICY**

FAIRCHILD'S PRODUCTS ARE NOT AUTHORIZED FOR USE AS CRITICAL COMPONENTS IN LIFE SUPPORT DEVICES OR SYSTEMS WITHOUT THE EXPRESS WRITTEN APPROVAL OF THE PRESIDENT OF FAIRCHILD SEMICONDUCTOR CORPORATION. As used herein:

1. Life support devices or systems are devices or systems which, (a) are intended for surgical implant into the body, or (b) support or sustain life, and (c) whose failure to perform when properly used in accordance with instructions for use provided in the labeling, can be reasonably expected to result in a significant injury to the user.
2. A critical component in any component of a life support device or system whose failure to perform can be reasonably expected to cause the failure of the life support device or system, or to affect its safety or effectiveness.

[www.fairchildsemi.com](http://www.fairchildsemi.com)