

2.5V/3.3V, High Bandwidth, Hot Insertion
10-Bit, 2-Port, Bus Switch

Features

- Near-Zero propagation delay
- Low noise, 25-ohm version (PI3C32384)
- 5-ohm switches connect inputs to outputs (PI3C3384)
- High Bandwidth (>400 MHz)
- Permits Hot Insertion.
- Rail-to-Rail, 3.3V or 2.5V Switching
- 5V I/O Tolerant
- 2.5V Supply Voltage Operation
- Packaging (Pb-free & Green available):
 - 24-pin 150-mil wide plastic QSOP (Q)
 - 24-pin 173-mil wide plastic TSSOP (L)

Description

Pericom Semiconductor's PI3C3384 and PI3C32384 are 2.5V or 3.3V, high bandwidth 10-bit, 2-port bus switches designed with a low On-Resistance allowing inputs to be connected directly to outputs. The bus switch creates no additional propagational delay or additional ground bounce noise. The switches are turned ON by the Bus Enable (\overline{BE}) input signal. Two bus enable signals are provided, one for each of the upper and lower five bits of the two 10-bit buses.

The PI3C32384 is designed with an internal 25-ohm resistor reducing noise reflection in high-speed applications.

Applications

- High Bandwidth Data switching
- Hot Docking

Block Diagram

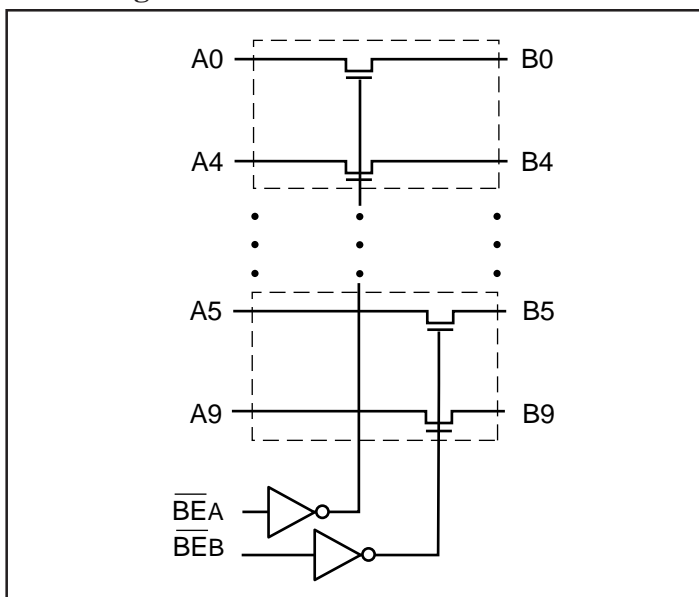

Pin Configuration

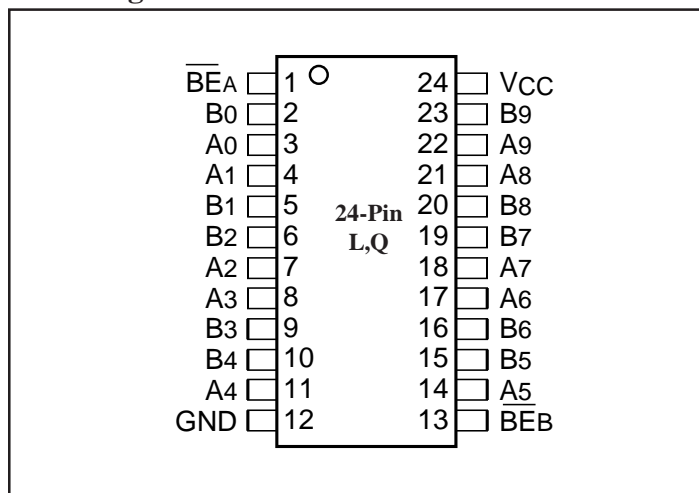

Truth Table⁽¹⁾

Function	\overline{BEA}	\overline{BEB}	B0-B4	B5-B9
Disconnect	H	H	Hi-Z	Hi-Z
Connect	L	H	A0-A4	Hi-Z
Connect	H	L	Hi-Z	A5-A9
Connect	L	L	A0-A4	A5-A9

Note:

1. H = High Voltage Level, X = Don't Care,
L = Low Voltage Level, Hi-Z = High Impedance

Pin Description

Pin Name	Description
\overline{BEA} , \overline{BEB}	Bus Enable Inputs (Active LOW)
A0 - A9	Bus A
B0 - A9	Bus B
GND	Ground
VCC	Power

Maximum Ratings

(Above which the useful life may be impaired. For user guidelines, not tested.)

Storage Temperature	-65°C to +150°C
Ambient Temperature with Power Applied	-40°C to +85°C
Supply Voltage to Ground Potential (Inputs & V _{CC} Only) ...	-0.5V to +4.6V
Supply Voltage to Ground Potential (Outputs & D/O Only)	-0.5V to +4.6V
DC Input Voltage	-0.5V to +5.5V
DC Output Current	120 mA
Power Dissipation	0.5W

Note:

Stresses greater than those listed under MAXIMUM RATINGS may cause permanent damage to the device. This is a stress rating only and functional operation of the device at these or any other conditions above those indicated in the operational sections of this specification is not implied. Exposure to absolute maximum rating conditions for extended periods may affect reliability.

DC Electrical Characteristics (Over Operating Range, T_A = -40°C to +85°C, V_{CC} = 3.3V ± 10%)

Parameters	Description	Test Conditions ⁽¹⁾	Min.	Typ. ⁽²⁾	Max.	Units	
V _{IH}	Input HIGH Voltage	Guaranteed Logic HIGH Level	2.0			V	
V _{IL}	Input LOW Voltage	Guaranteed Logic LOW Level	-0.5		0.8		
I _{IH}	Input HIGH Current	V _{CC} = Max., V _{IN} = V _{CC}			±1	µA	
I _{IL}	Input LOW Current	V _{CC} = Max., V _{IN} = GND			±1		
I _{OZH}	High-Impedance Output Current	0 ≤ A, B ≤ V _{CC}			±1		
V _{IK}	Clamp diode Voltage	V _{CC} = Min., I _{IN} = -18mA		-0.73	-1.2	V	
R _{ON}	Switch On Resistance ⁽³⁾	V _{CC} = Min., V _{IN} = 0.0V I _{ON} = 48mA or 64mA	PI3C3384	5	7	Ω	
			PI3C32384	18	28		40
		V _{CC} = Min., V _{IN} = 2.4V I _{ON} = 15mA	PI3C3384		8		15
			PI3C32384	18	35		48

Capacitance (T_A = 25°C f = 1 MHz)

Parameters ⁽⁴⁾	Description	Test Conditions	Typ.	Units
C _{IN}	Input Capacitance	V _{IN} = 0V	3.5	pF
C _{OFF}	A/B Capacitance, Switch Off		5.0	
C _{ON}	A/B Capacitance, Switch On		10.0	

Notes:

- For Max. or Min. conditions, use appropriate value specified under Electrical Characteristics for the applicable device type.
- Typical values are at V_{CC} = 3.3V, T_A = 25°C ambient and maximum loading.
- Measured by the voltage drop between A and B pin at indicated current through the switch. ON resistance is determined by the lower of the voltages on the two (A,B) pins.
- This parameter is determined by device characterization but is not production tested.

Power Supply Characteristics

Parameters	Description	Test Conditions ⁽¹⁾		Min.	Typ. ⁽²⁾	Max.	Units
I _{CC}	Quiescent Power Supply Current	V _{CC} = Max., V _{IN} = GND or V _{CC}	PI3C3384 PI3C32384		260	500	μA
ΔI _{CC}	Supply Current per Input @ TTL HIGH	V _{CC} = Max., V _{IN} = 3.0V ⁽³⁾				750	

Notes:

1. For Max. or Min. conditions, use appropriate value specified under Electrical Characteristics for the applicable device.
2. Typical values are at V_{CC} = 3.3V, +25°C ambient.
3. Per TTL driven input (control inputs only); A and B pins do not contribute to I_{CC}.

Switching Characteristics over 3.3V Operating Range

Parameters	Description	Conditions ⁽¹⁾	PI3C3384		PI3C32384		Units
			Com.		Com.		
			Min.	Max.	Min.	Max.	
t _{PLH} t _{PHL}	Propogation Delay ^(2,3) Ax to Bx, Bx to Ax	C _L = 50pF R _L = 500-ohm		0.25		1.25	ns
t _{PZH} t _{PZL}	Bus Enable Time B _{Ex} to Ax or Bx	C _L = 50pF R _L = 500-ohm	1.5	6.5	1.5	6.5	
t _{PHZ} t _{PLZ}	Bus Disable Time B _{Ex} to Ax or Bx	R = 500-ohm	1.5	5.5	1.5	5.5	

Switching Characteristics over 2.5V Operating Range

Parameters	Description	Conditions ⁽¹⁾	PI3C3384		PI3C32384		Units
			Com.		Com.		
			Min.	Max.	Min.	Max.	
t _{PLH} t _{PHL}	Propogation Delay ^(2,3) Ax to Bx, Bx to Ax	C _L = 50pF R _L = 500-ohm		0.25		1.25	ns
t _{PZH} t _{PZL}	Bus Enable Time B _{Ex} to Ax or Bx	C _L = 50pF R _L = 500-ohm	1.5	9.8	1.5	9.8	
t _{PHZ} t _{PLZ}	Bus Disable Time B _{Ex} to Ax or Bx	R = 500-ohm	1.5	8.3	1.5	8.3	

Notes:

1. See test circuit and waveforms.
2. This parameter is guaranteed but not tested on Propagation Delays.
3. The bus switch contributes no propagational delay other than the RC delay of the ON resistance of the switch and the load capacitance. The time constant for the switch alone is of the order of 0.25ns for 50pF load. Since this time constant is much smaller than the rise/fall times of typical driving signals, it adds very little propagational delay to the system. Propagational delay of the bus switch when used in a system is determined by the driving circuit on the driving side of the switch and its interaction with the load on the driven side.

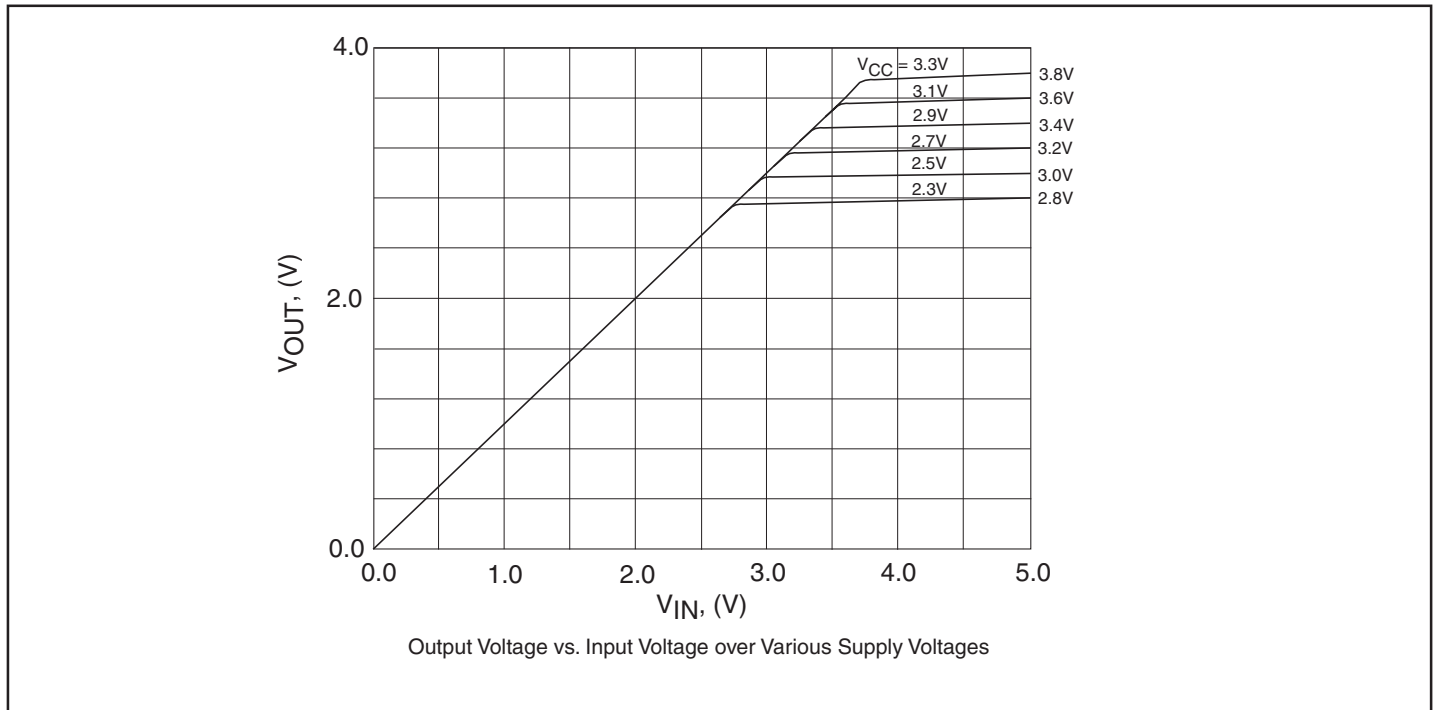

Test Circuit

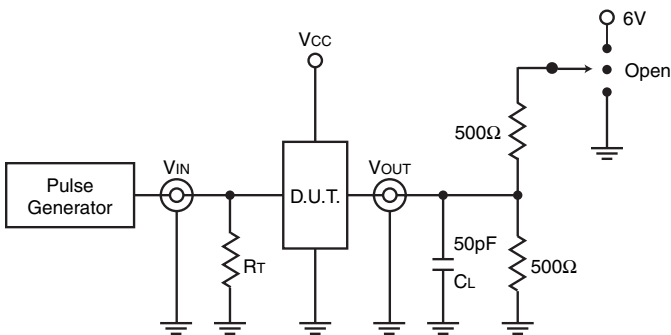

Switch Position

Test	Switch
Disable LOW	6V
Enable LOW	6V
Disable HIGH	GND
Enable HIGH	GND
t_{pD}	Open

Definitions:

C_L = Load capacitance (includes jig and probe capacitance)

R_T = Termination resistance (should be equal to Z_{OUT} of the pulse generator)

Enable and Disable Timing

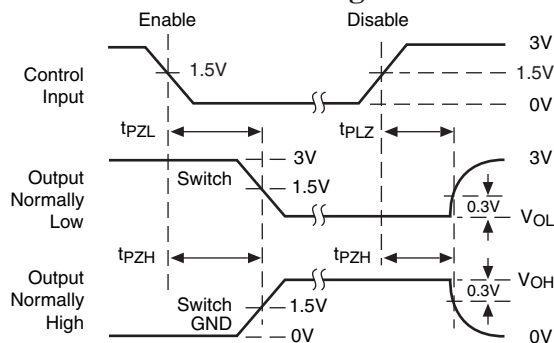

1. Input Control Enable = Low; Input Control Disable = High
2. Pulse Generator for all pulses:
Rate ≤ 1.0 MHz; $Z_{OUT} \leq 50\Omega$; $t_r, t_f \leq 2.5$ ns

Propagation Delay

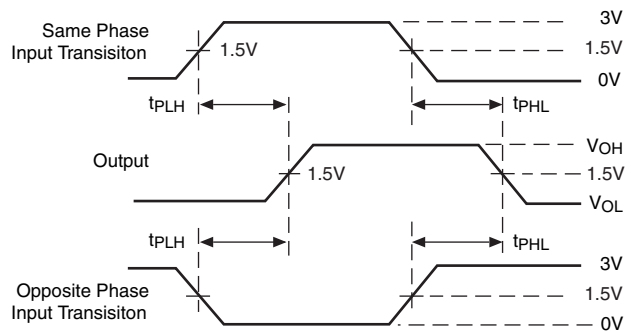

Packaging Mechanical: 24-pin QSOP (Q)

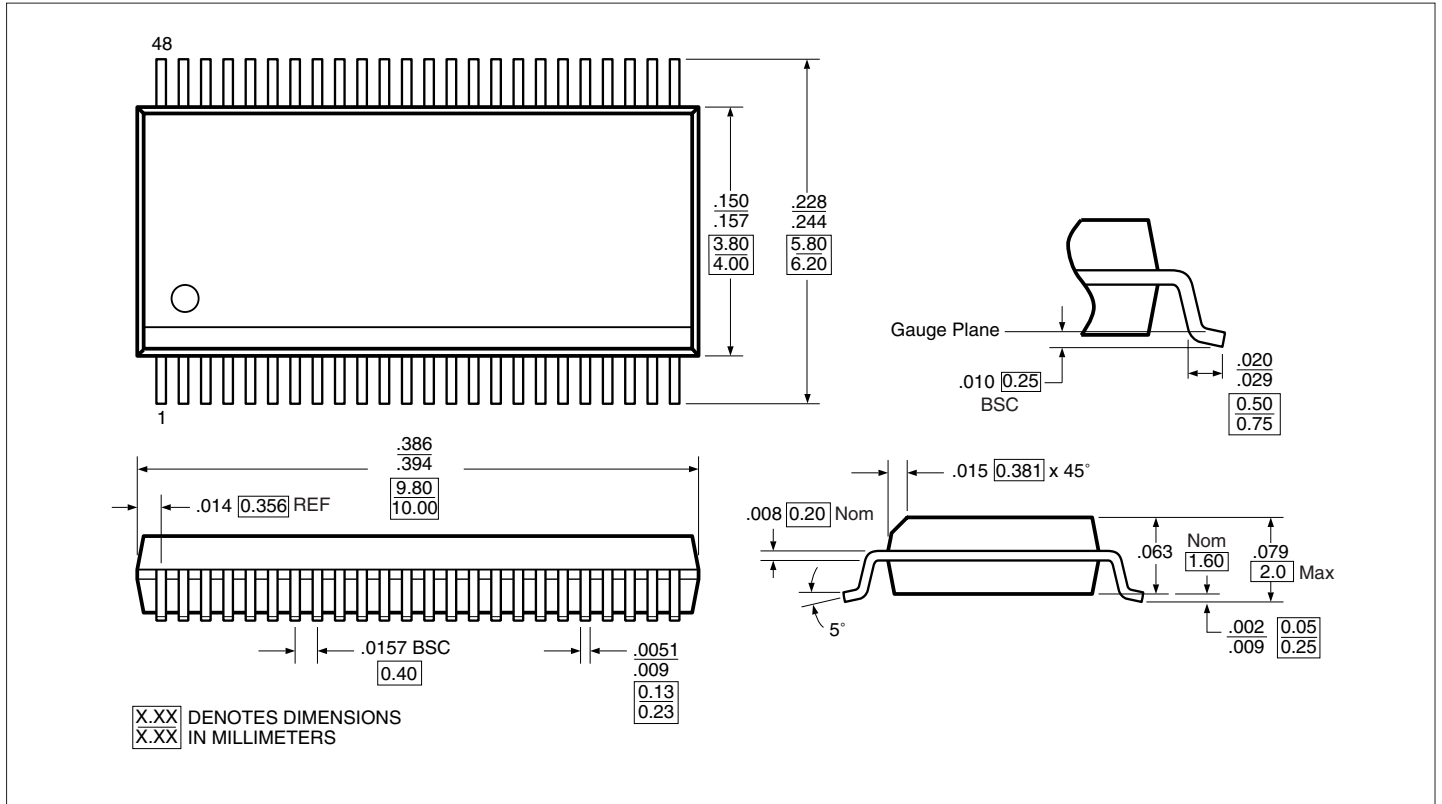

Packaging Mechanical: 24-pin TSSOP (L)

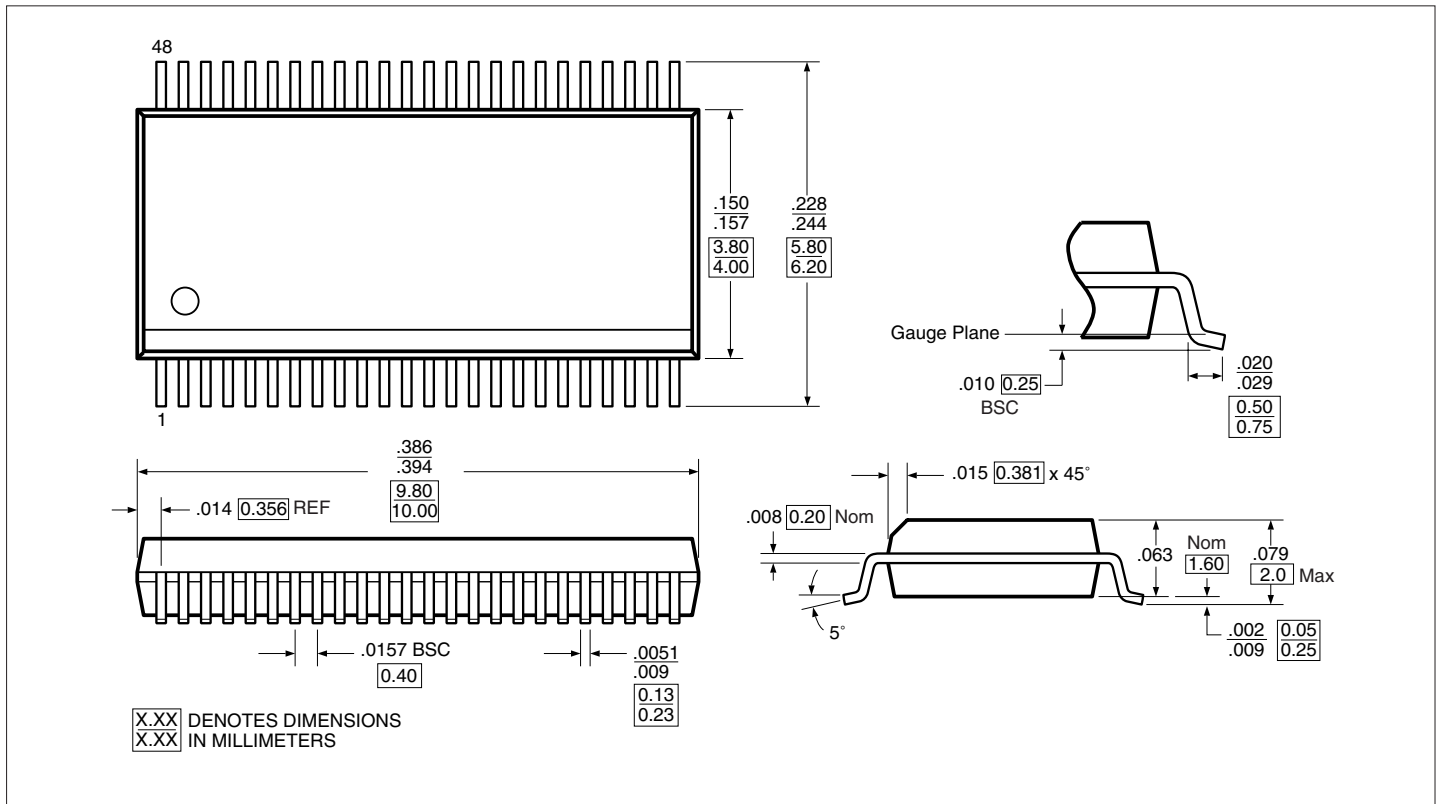



Ordering Information

Ordering Code	Package Code	Package Type
PI3C3384L	L	24-pin TSSOP
PI3C3384LE	L	Pb-free & Green, 24-pin TSSOP
PI3C3384Q	Q	24-pin QSOP
PI3C3384QE	Q	Pb-free & Green, 24-pin QSOP
PI3C32384L	L	24-pin TSSOP
PI3C32384LE	L	Pb-free & Green, 24-pin TSSOP
PI3C32384Q	Q	24-pin QSOP
PI3C32384QE	Q	Pb-free & Green, 24-pin QSOP

Notes:

- Thermal characteristics can be found on the company web site at www.pericom.com/packaging/
- E = Pb-free & Green
- X suffix = Tape/Reel