

High-current Density Surface Mount Schottky Rectifier

Major Ratings and Characteristics

$I_{F(AV)}$	4.0 A
V_{RRM}	30 V, 40 V
I_{FSM}	100 A
V_F	0.38 V, 0.42 V
$T_j \text{ max.}$	150 °C



DO-214AA (SMB)

Features

- Low profile package
- Ideal for automated placement
- Guardring for overvoltage protection
- Low power losses, high efficiency
- Very low forward voltage drop
- High surge capability
- Meets MSL level 1, per J-STD-020C
- Solder Dip 260 °C, 40 seconds



Mechanical Data

Case: DO-214AA (SMB)

Epoxy meets UL 94V-0 Flammability rating

Terminals: Matte tin plated leads, solderable per J-STD-002B and JESD22-B102D

E3 suffix for commercial grade, HE3 suffix for high reliability grade (AEC Q101 qualified)

Polarity: Color band denotes the cathode end

Typical Applications

For use in low voltage high frequency inverters, free-wheeling, dc-to-dc converters, and polarity protection applications

Maximum Ratings

$T_A = 25\text{ °C}$ unless otherwise specified

Parameter	Symbol	SSB43L	SSB44	Unit
Device marking code		43L	S44	
Maximum repetitive peak reverse voltage	V_{RRM}	30	40	V
Maximum RMS voltage	V_{RMS}	21	28	V
Maximum DC blocking voltage	V_{DC}	30	40	V
Max. average forward rectified current at T_L (See Fig. 1)	$I_{F(AV)}$	4.0		A
Peak forward surge current 8.3 ms single half sine-wave superimposed on rated load	I_{FSM}	100		A
Voltage rate of change (rated V_R)	dv/dt	10000		V/ μ s
Operating junction temperature range	T_J	- 65 to + 150		°C
Storage temperature range	T_{STG}	- 65 to + 150		C

Electrical Characteristics

T_A = 25 °C unless otherwise specified

Parameter	Test condition	Symbol	Typ.	Max.	Typ.	Max.	Unit
Maximum instantaneous forward voltage	at 4.0 A ⁽¹⁾	V _F	T _J = 25 °C	0.43	0.45	0.45	0.49
			T _J = 125 °C	0.33	0.38	0.37	0.42
Maximum DC reverse current at rated DC blocking voltage ⁽¹⁾		I _R	T _J = 25 °C	-	0.6	-	0.4
			T _J = 125 °C	35	45	25	40

Notes:

(1) Pulse test: 300 μs pulse width, 1 % duty cycle

Thermal Characteristics

T_A = 25 °C unless otherwise specified

Parameter	Symbol	SSB43L	SSB44	Unit
Typical thermal resistance ⁽¹⁾	R _{θJA}	70		°C/W
	R _{θJL}	23		

Notes:

(1) Aluminum substrate mounted

Ratings and Characteristics Curves

(T_A = 25 °C unless otherwise noted)

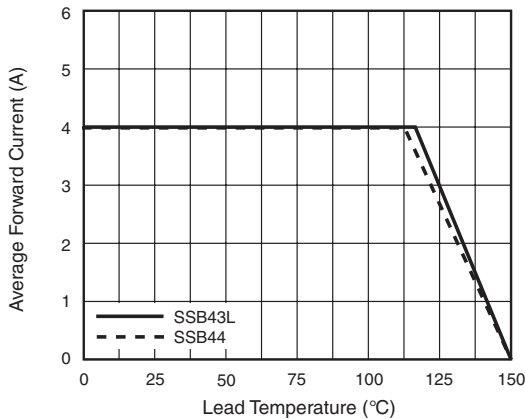

Figure 1. Forward Current Derating Curve

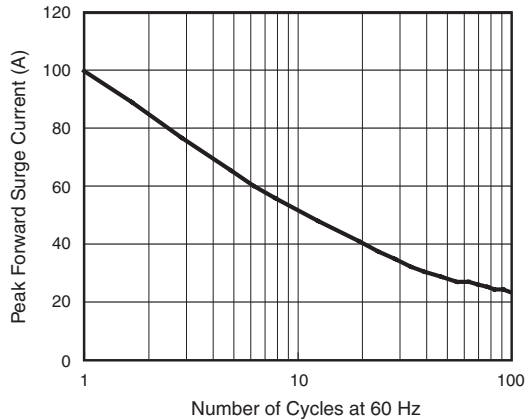

Figure 2. Maximum Non-Repetitive Peak Forward Surge Current

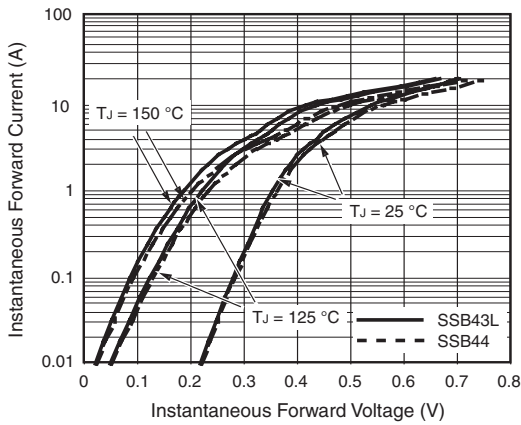

Figure 3. Typical Instantaneous Forward Characteristics

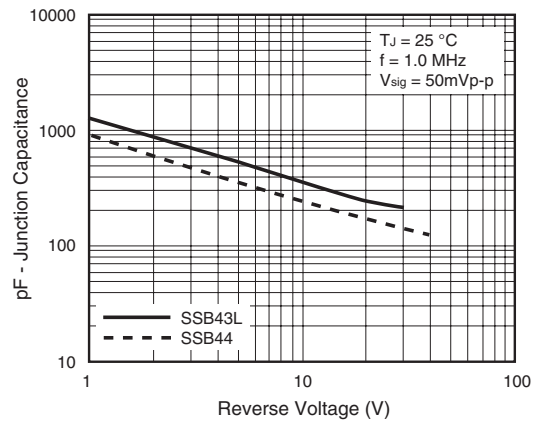

Figure 5. Typical Junction Capacitance

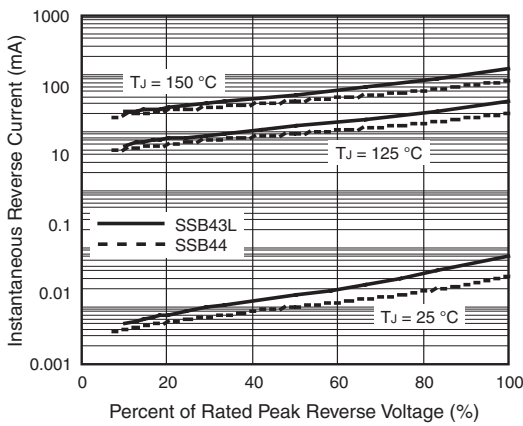
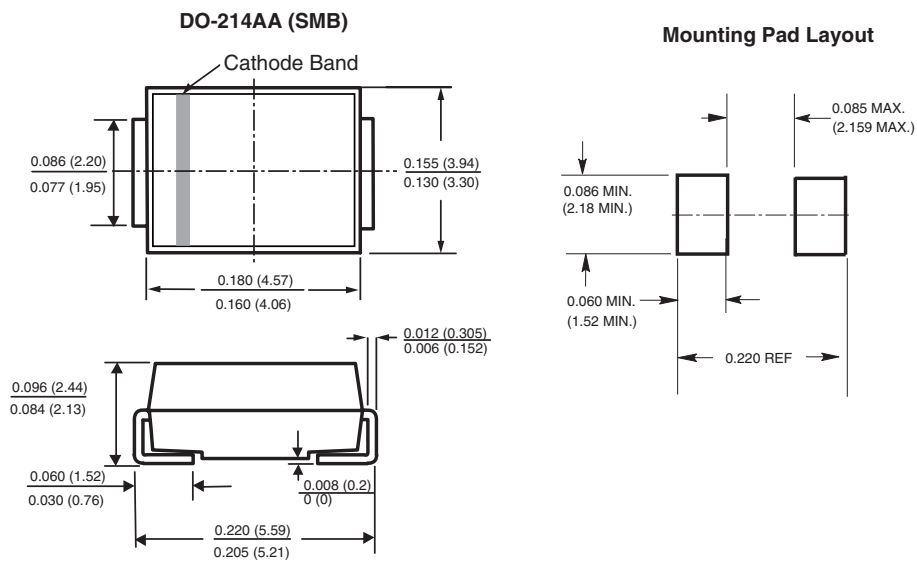

Figure 4. Typical Reverse Characteristics

Package outline dimensions in inches (millimeters)





Notice

Specifications of the products displayed herein are subject to change without notice. Vishay Intertechnology, Inc., or anyone on its behalf, assumes no responsibility or liability for any errors or inaccuracies.

Information contained herein is intended to provide a product description only. No license, express or implied, by estoppel or otherwise, to any intellectual property rights is granted by this document. Except as provided in Vishay's terms and conditions of sale for such products, Vishay assumes no liability whatsoever, and disclaims any express or implied warranty, relating to sale and/or use of Vishay products including liability or warranties relating to fitness for a particular purpose, merchantability, or infringement of any patent, copyright, or other intellectual property right.

The products shown herein are not designed for use in medical, life-saving, or life-sustaining applications. Customers using or selling these products for use in such applications do so at their own risk and agree to fully indemnify Vishay for any damages resulting from such improper use or sale.