

Product Features

- Functionally compatible with LCX family of products
- 1.65V - 3.6V V_{CC} supply operation, -40°C to 85°C
- ESD Protection exceeds 2000V, Human Body Model 200V, Machine Model
- Inputs accept up to 5.5V
- Balanced sink and source output drives (24mA)
- Low ground bounce outputs, <0.8V @ 3.3V, 25°C
- Supports live insertion
- Packages available:
 - 14-pin 173-mil wide plastic TSSOP(L)
 - 14-pin 150-mil wide plastic SOIC(W)

Product Description

Pericom Semiconductor's PI74LVC series of logic circuits are produced using the Company's advanced 0.5 micron CMOS technology, achieving high speed while maintaining low power operation.

The PI74LVC04A Hex Inverter contains six independent inverters that perform the Boolean function $Y = \bar{A}$.

Inputs can be driven from either 3.3V or 5.0V devices allowing the PI74LVC04A to be used as a translator in a mixed 3.3V/5.0V system.

Logic Diagram

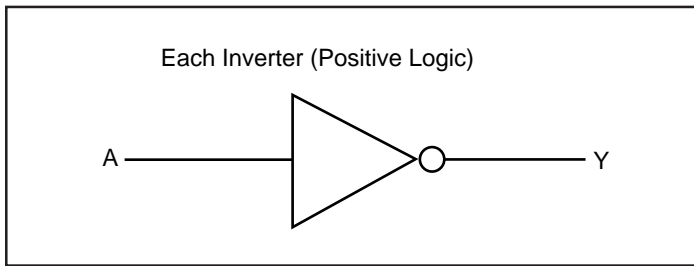

Truth Table

(Each Inverter)

Input A	Output Y
H	L
L	H

Notes:

H=HIGH Logic Level
L=LOW Logic Level

Pin Configuration

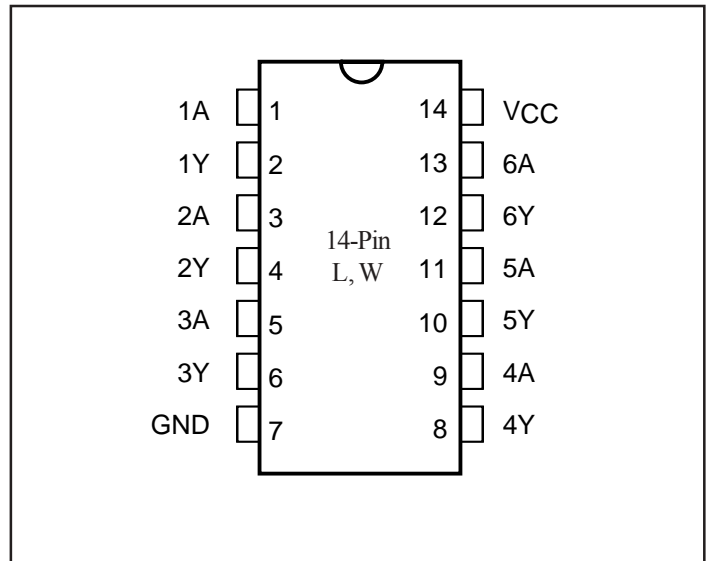

Maximum Ratings

(Above which the useful life may be impaired. For user guidelines, not tested.)

Supply voltage range, V_{CC}	-0.5V to 6.5V
Input voltage range, $V_I^{(1)}$	-0.5V to 6.5V
Output voltage range, $V_O^{(1,2)}$	-0.5V to $V_{CC}+0.5V$
Input clamp current, $I_{IK} (V_I < 0)$	-50mA
Output clamp current, $I_{OK} (V_O < 0)$	-50mA
Continuous output current, I_O	$\pm 50mA$
Continuous current through V_{CC} or GND	$\pm 100mA$
Package thermal impedance, $\theta_{JA}^{(3)}$: W package	113°C/W
L package	100°C/W
Storage Temperature range, T_{stg}	65°C to 150°C

Notes:

Stresses greater than those listed under MAXIMUM RATINGS may cause permanent damage to the device. This is a stress rating only and functional operation of the device at these or any other conditions above those indicated in the operational sections of this specification is not implied. Exposure to absolute maximum rating conditions for extended periods may affect reliability.

1. The Input negative-voltage and output voltage ratings may be exceeded if the input and output current ratings are observed.
2. The value of V_{CC} is provided in the recommended operating conditions table.
3. The package thermal impedance is calculated in accordance with JESD 51.

Recommended Operating Conditions⁽⁴⁾

Parameter	Description	Min.	Max.	Units	
V _{CC}	Supply Voltage	Operating	1.65	3.6	V
		Data retention only	1.5		
V _{IH}	High-level Input Voltage	V _{CC} = 1.65V to 1.95V	0.65 x V _{CC}		
		V _{CC} = 2.3V to 2.7V	1.7		
		V _{CC} = 2.7V to 3.6V	2.0		
V _{IL}	Low-level Input Voltage	V _{CC} = 1.65V to 1.95V		0.35 x V _{CC}	
		V _{CC} = 2.3V to 2.7V		0.7	
		V _{CC} = 2.7V to 3.6V		0.8	
V _I	Input Voltage	0	5.5		
V _O	Output Voltage	0	V _{CC}		
I _{OH}	High-level output current	V _{CC} = 1.65V		-4	mA
		V _{CC} = 2.3V		-8	
		V _{CC} = 2.7V		-12	
		V _{CC} = 3V		-24	
I _{OL}	Low-level output current	V _{CC} = 1.65V		4	
		V _{CC} = 2.3V		8	
		V _{CC} = 2.7V		12	
		V _{CC} = 3V		24	
Δt / Δv	Input transition rise or fall time	0	10	ns/V	
T _A	Operating free-air temperature	-40	85	°C	

Note:

4. All unused inputs must be held at V_{CC} or GND to ensure proper device operation.

DC Electrical Characteristics (Over Recommended Operating Free-Air Temperature Range, unless otherwise noted)

Parameters	Test Conditions	V _{CC}	Min.	Typ.†	Max.	Units
V _{OH}	I _{OH} = -100μA	1.65V to 3.6V	V _{CC} - 0.2V			V
	I _{OH} = -4mA	1.65V	1.2			
	I _{OH} = -8mA	2.3V	1.7			
	I _{OH} = -12mA	2.7V	2.2			
		3V	2.4			
I _{OH} = -24mA	3V	2.2				
V _{OL}	I _{OL} = 100μA	1.65V to 3.6V			0.2	V
	I _{OL} = 4mA	1.65V			0.45	
	I _{OL} = 8mA	2.3V			0.7	
	I _{OL} = 12mA	2.7V			0.4	
	I _{OL} = 24mA	3V			0.55	
I _I	V _I = 5.5V or GND	3.6V			±5	μA
I _{CC}	V _I = V _{CC} or GND I _O = 0	3.6V			10	
ΔI _{CC}	One input a V _{CC} - 0.6V Other inputs at V _{CC} or GND	2.7V to 3.6V			500	
C _I	V _I = V _{CC} or GND	3.3V		3		pF

† All typical values are measured at V_{CC} = 3.3V, T_A = 25°C

Switching Characteristics

(Over recommended operating free-air temperature range, unless otherwise noted, see Figures 1 through 3)

Parameters	From (Input)	To (Output)	V _{CC} = 1.8V ±0.15V		V _{CC} = 2.5V ±0.2V		V _{CC} = 2.7V		V _{CC} = 3.3V ±0.3V		Units
			Min.	Max.	Min.	Max.	Min.	Max.	Min.	Max.	
t _{pd}	A or B	Y	1	13.5	1	7.5	1	5.5	1	4.5	ns
tsk(o) [§]										1	

§ Skew between any two outputs of the same package switching in the same direction.

Operating Characteristics, T_A = 25°C

Parameter	Description	Test Conditions	V _{CC} = 1.8V	V _{CC} = 2.5V	V _{CC} = 3.3V	Units
			Typ.	Typ.	Typ.	
C _{pd}	Power Dissipation Capacitance per gate	f = 10 MHz	22	27	35	pF

PARAMETER MEASUREMENT INFORMATION

$V_{CC} = 1.8V \pm 0.15V$

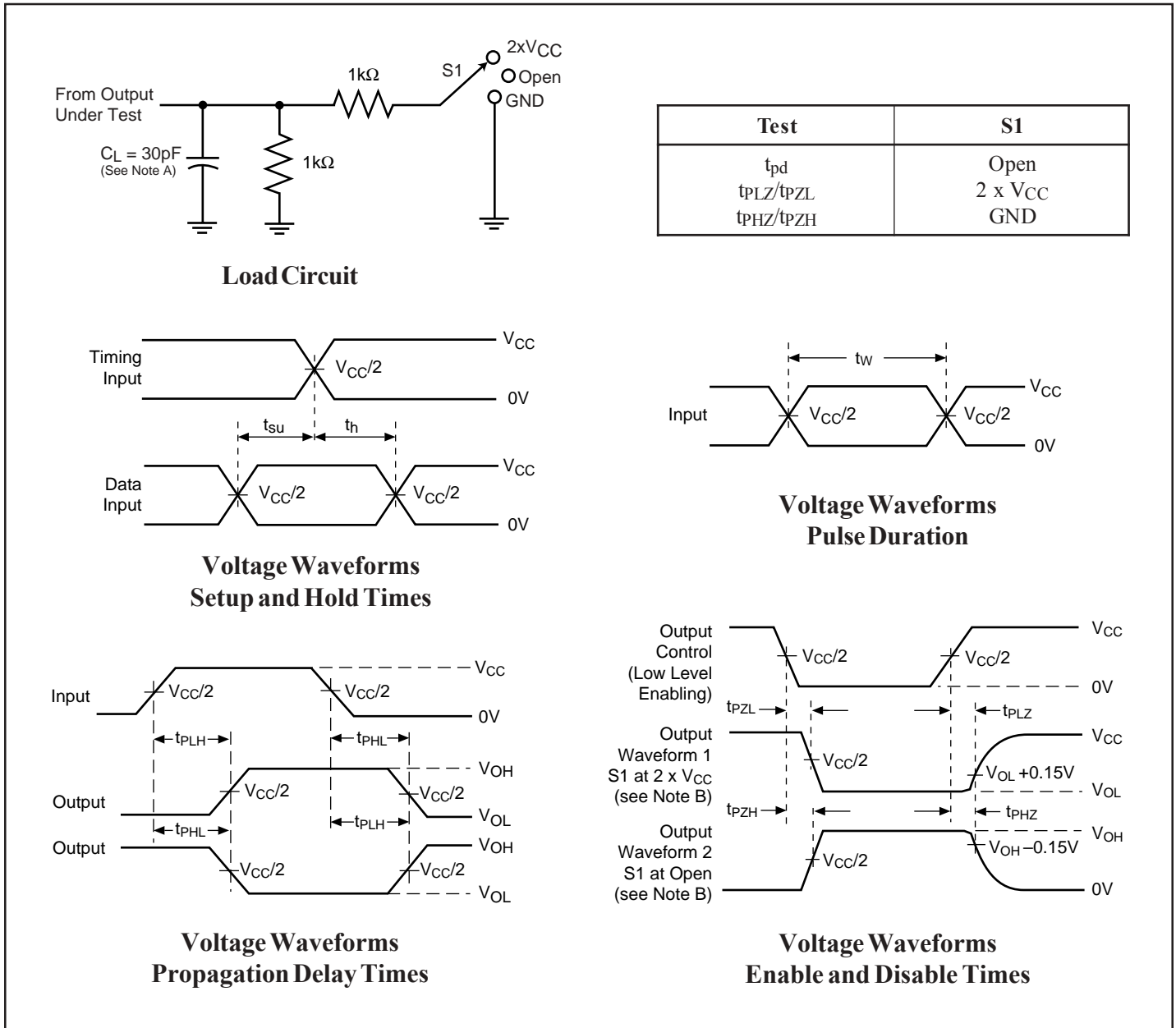

Figure 1. Load Circuit and Voltage Waveforms

Notes:

- A. C_L includes probe and jig capacitance.
- B. Waveform 1 is for an output with internal conditions such that the output is low except when disabled by the output control. Waveform 2 is for an output with internal conditions such that the output is high except when disabled by the output control.
- C. All input impulses are supplied by generators having the following characteristics: PRR ≤ 10 MHz, Z_O = 50 Ω , t_R ≤ 2.0ns, t_F ≤ 2.0ns.
- D. Outputs are measured one at a time with one transition per measurement.
- E. t_{PLZ} and t_{PHZ} are the same as t_{dis}
- F. t_{PZL} and t_{PZH} are the same as t_{en}
- G. t_{PLH} and t_{PHL} are the same as t_{pd}
- H. Not all parameters and waveforms are applicable to all devices.

PARAMETER MEASUREMENT INFORMATION

$V_{CC} = 2.5V \pm 0.2V$

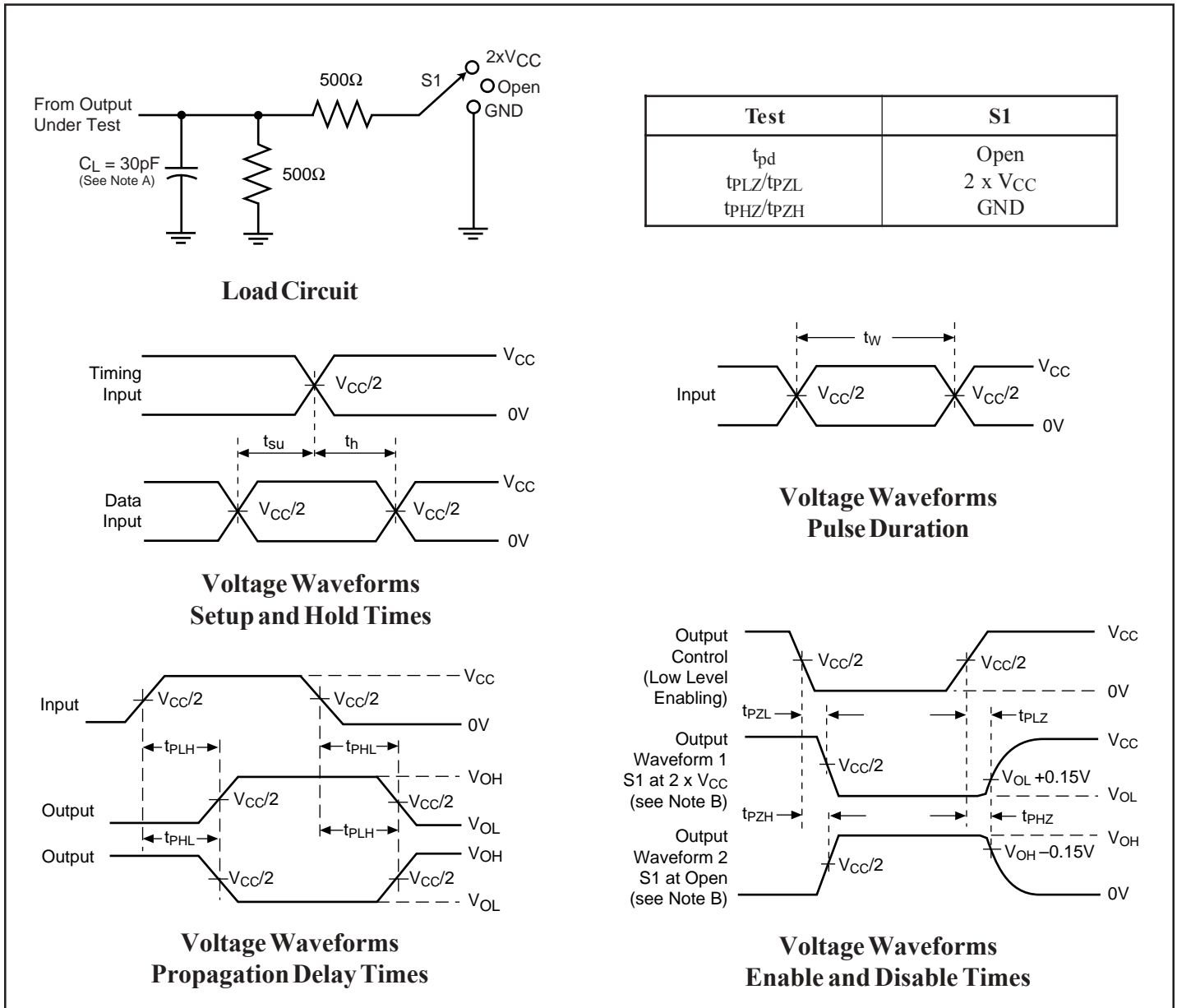

Figure 2. Load Circuit and Voltage Waveforms

Notes:

- A. C_L includes probe and jig capacitance.
- B. Waveform 1 is for an output with internal conditions such that the output is low except when disabled by the output control.
Waveform 2 is for an output with internal conditions such that the output is high except when disabled by the output control.
- C. All input impulses are supplied by generators having the following characteristics: $PRR \leq 10 \text{ MHz}$, $Z_O = 50\Omega$, $t_R \leq 2.0\text{ns}$, $t_F \leq 2.0\text{ns}$.
- D. Outputs are measured one at a time with one transition per measurement.
- E. t_{PLZ} and t_{PHZ} are the same as t_{dis}
- F. t_{PZL} and t_{PZH} are the same as t_{en}
- G. t_{PLH} and t_{PHL} are the same as t_{pd}
- H. Not all parameters and waveforms are applicable to all devices.

PARAMETER MEASUREMENT INFORMATION

$V_{CC} = 2.7V$ and $3.3V \pm 0.3V$

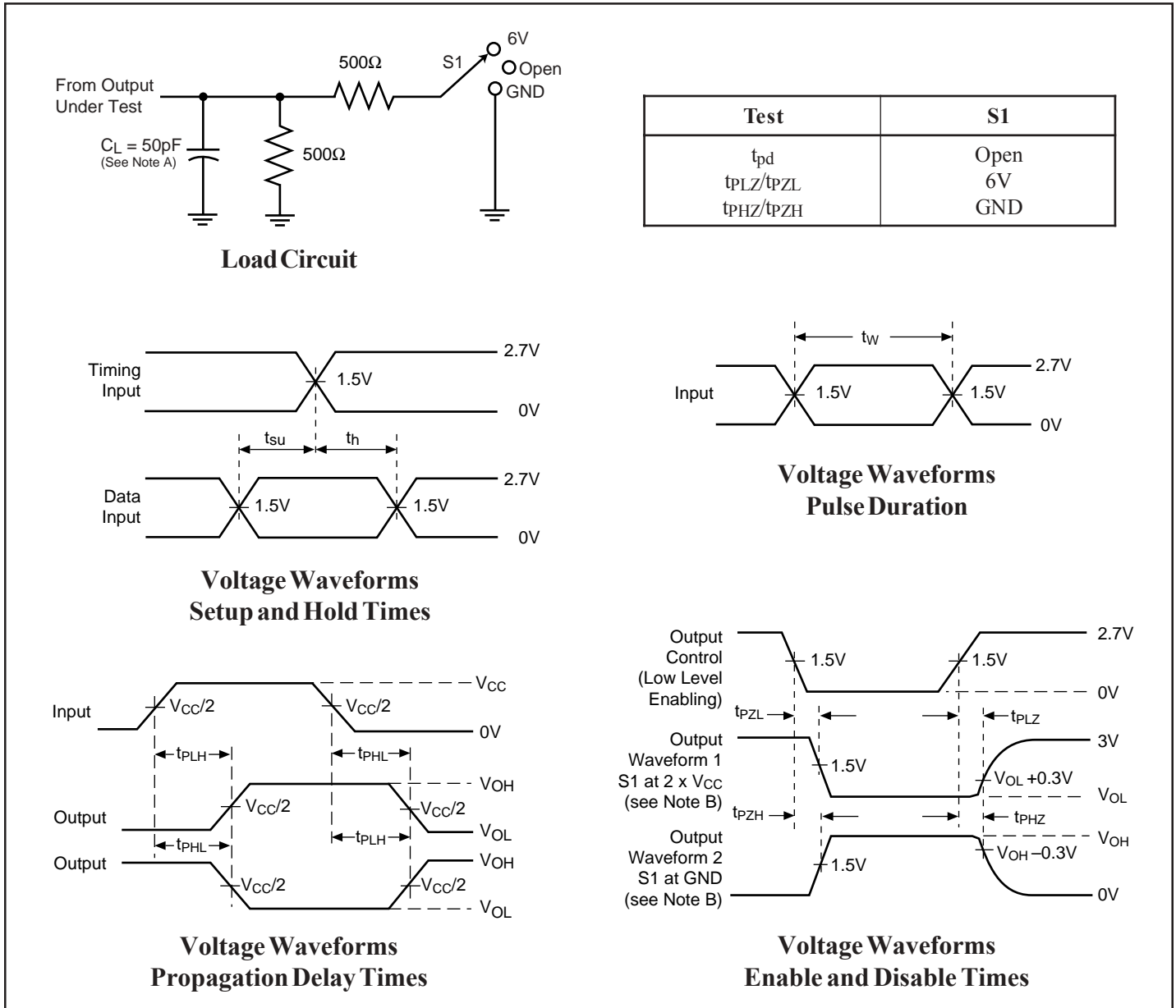
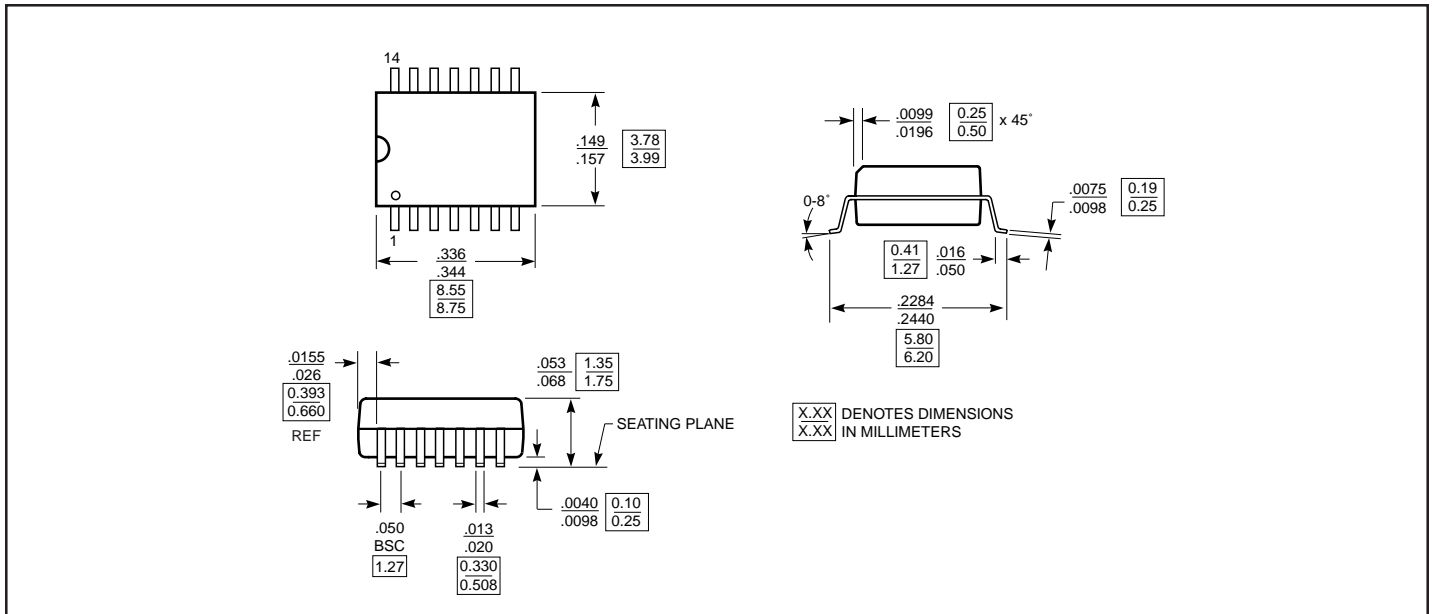

Figure 3. Load Circuit and Voltage Waveforms

Notes:

- A. C_L includes probe and jig capacitance.
- B. Waveform 1 is for an output with internal conditions such that the output is low except when disabled by the output control. Waveform 2 is for an output with internal conditions such that the output is high except when disabled by the output control.
- C. All input impulses are supplied by generators having the following characteristics: $PRR \leq 10$ MHz, $Z_O = 50\Omega$, $t_R \leq 2.5ns$, $t_F \leq 2.5ns$.
- D. Outputs are measured one at a time with one transition per measurement.
- E. t_{PLZ} and t_{PHZ} are the same as t_{dis}
- F. t_{PZL} and t_{PZH} are the same as t_{en}
- G. t_{PLH} and t_{PHL} are the same as t_{pd}
- H. Not all parameters and waveforms are applicable to all devices.

14-pin 150-mil wide SOIC (W) Package



14-pin 173-mil wide TSSOP (L) Package

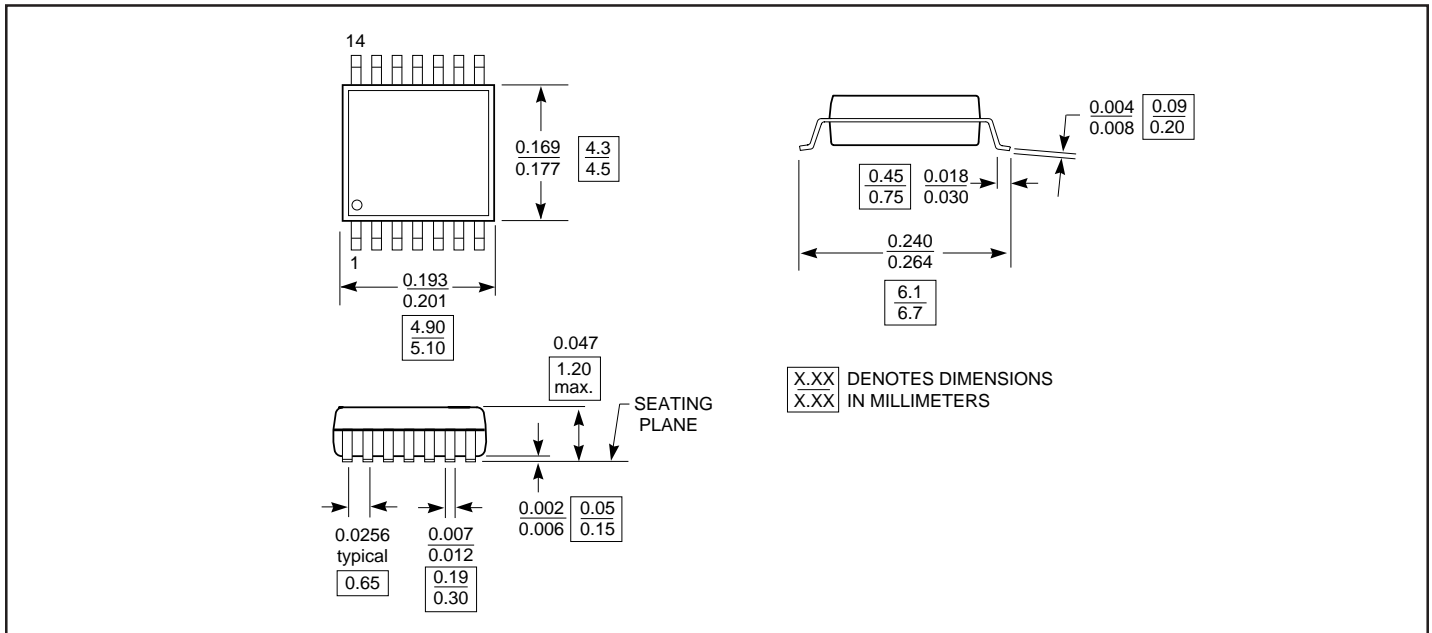

Ordering Information

Ordering Code	Package Type	Operating Range
PI74LVC04AL	14-pin, 173-mil wide plastic TSSOP	-40°C to 85°C
PI74LVC04AW	14-pin, 150-mil wide plastic SOIC	