

Features

- Optimized for 5V operation
- Stable at gain of 2
- 100 MHz Gain bandwidth product
- 130 V/ μ s slew rate
- Drives 150 Ω load to video levels
- Input and outputs operate at negative supply rail
- -60 dB isolation at 4.2 MHz

Applications

- Consumer video amplifier
- Active filters/integrators
- Cost sensitive applications
- Single supply amplifiers

Ordering Information

Part No	Temp. Range	Package	Outline #
EL2221CN	-40°C to +85°C	8-lead P-DIP	MDP0031
EL2221CS	-40°C to +85°C	8-lead SO	MDP0027

General Description

The EL2221C operational amplifier, built using Elantec's complementary bipolar process, offers unprecedented high frequency performance at a very low cost. It is suitable for any application, such as consumer video, where traditional DC performance specifications are of secondary importance to the high frequency specifications. On a 5V supply at a gain of +2 the EL2221C will drive a 150 Ω load to +2V, with a bandwidth of 100 MHz. This device achieves 0.1 dB bandwidth at 5 MHz.

The recommended power supply voltage is 5V. At zero and 5V supplies, the inputs will operate to ground. When the outputs are at 0V the amplifier draws only 2.4 mA of supply current.

Connection Diagram

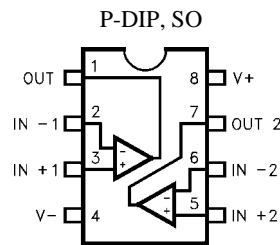

Note: All information contained in this data sheet has been carefully checked and is believed to be accurate as of the date of publication; however, this data sheet cannot be a "controlled document". Current revisions, if any, to these specifications are maintained at the factory and are available upon your request. We recommend checking the revision level before finalization of your design documentation.

EL2221C

Dual, Low Cost, Gain of 2, Video Op Amp

Absolute Maximum Ratings ($T_A = 25^\circ\text{C}$)

Total Supply Voltage	18V	Power Dissipation	See Curves
Input Voltage	-6V _S	Storage Temperature Range	-65°C to +150°C
Differential Input Voltage	6V	Operating Temperature Range	-40°C to +85°C
Peak Output Current	75 mA per amplifier		

Important Note:

All parameters having Min/Max specifications are guaranteed. The Test Level column indicates the specific device testing actually performed during production and Quality inspection. Elantec performs most electrical tests using modern high-speed automatic test equipment, specifically the LTX77 Series system. Unless otherwise noted, all tests are pulsed tests, therefore $T_J = T_C = T_A$.

Test Level	Test Procedure
I	100% production tested and QA sample tested per QA test plan QCX0002.
II	100% production tested at $T_A = 25^\circ\text{C}$ and QA sample tested at $T_A = 25^\circ\text{C}$, T_{MAX} and T_{MIN} per QA test plan QCX0002.
III	QA sample tested per QA test plan QCX0002.
IV	Parameter is guaranteed (but not tested) by Design and Characterization Data.
V	Parameter is typical value at $T_A = 25^\circ\text{C}$ for information purposes only.

DC Characteristics

$V_S = +5V$, $R_L = 1K\Omega$, $V_{IN} = 1V$, $T_A = 25^\circ\text{C}$ unless otherwise specified.

Parameter	Description	Conditions	Min	Typ	Max	Test Level	Units
V_{OS}	Input Offset Voltage		-20	10	20	I	mV
TCV_{OS}	Average Offset Voltage Drift	[1]		-50		V	$\mu\text{V}/^\circ\text{C}$
I_B	Input Bias Current		-15	-7	-3	I	μA
I_{OS}	Input Offset Current			0.3	1.0	I	μA
TCI_{OS}	Average Offset Current Drift	[1]	-1	-3		V	$\text{nA}/^\circ\text{C}$
A_{VOL}	Open Loop Gain	$V_{OUT} = .5, 2.5, R_L = 1K\Omega$	160	250		I	V/V
		$V_{OUT} = .5, 2.5, R_L = 150K\Omega$	160	250		V	V/V
$PSRR$	Power Supply Rejection Ratio	$V_S = 4.5V$ to $5.5V$	43	50		I	dB
$CMRR$	Common Mode Rejection Ratio	$V_{CM} = 0V$ to $+3.8V$	60	65		I	dB
$CMIR$	Common Mode Input Range		0.0		3.0	I	V
V_{OUT}	Output Voltage Swing	$R_{FB} = R_G = 1K, R_L = 150\Omega$	2.8	3.2		I	V
I_{SC}	Output Short Circuit Current	Output to Ground [2]	75	125		I	mA
I_S	Supply Current	No Load (per channel) $V_{IN} = 0V$	2.0	2.4	3.0	I	mA
R_{IN}	Input Resistance	Differential		150		V	$K\Omega$
		Common Mode		1.5		V	$M\Omega$
C_{IN}	Input Capacitance	$A_v = +1$ @ 10 MHz		1		V	pF
R_{OUT}	Output Resistance			0.150		V	Ω
$PSOR$	Power Supply Operating Range	Single Supply	4		6	V	V

1. Measured from T_{MIN} to T_{MAX} .
2. A heat-sink is required to keep junction temperature below absolute maximum when an output is shorted.

EL2221C

Dual, Low Cost, Gain of 2, Video Op Amp

EL2221C

Closed Loop AC Electrical Characteristics

V_S=5V, AC Test Figure, T_A = 25°C unless otherwise specified

Parameter	Description	Conditions	Min	Typ	Max	Test Level	Units
BW	-3dB Bandwidth (V _{OUT} = 0.4 mVp-p) ±0.1 dB Bandwidth (V _{OUT} = 0.4 mVp-p)	A _V = +1		100		V	MHz
		A _V = +1		10		V	MHz
GBWP	Gain Bandwidth Product			50		V	MHz
PM	Phase Margin			55		V	(°)
SR	Slew Rate		85	130		V	V/μs
FBWP	Full Power Bandwidth	^[1]	8	11		V	MHz
t _R , t _F	Rise Time, Fall Time	0.1V step		2		V	ns
OS	Overshoot	0.1V step		15		V	%
t _{PD}	Propagation Delay			3.5		V	ns
t _S	Settling to 0.1% (A _V = 1)	V _S = 5V, 2V Step		80		V	ns
dG	Differential Gain ^[2]	NTSC/PAL		0.1		V	%
dP	Differential Phase ^[2]	NTSC/PAL		0.2		V	(°)
e _N	Input Noise Voltage	10 KHz		15		V	nV/rt(Hz)
i _N	Input Noise Current	10 KHz		1.5		V	nV/rt(Hz)
CS	Channel Separation	P = 5 MHz		55		V	dB

1. For V_S = 5V, V_{OUT} = 4V_{pp}. Full power bandwidth is based on slew rate measurement using: FPBW = SR/(2π*V_{peak})
2. Video performance measured at V_S = 5V, A_V = +2 with 2 times normal video level across R_L = 150Ω

EL2221C

Dual, Low Cost, Gain of 2, Video Op Amp

Typical Performance Curves

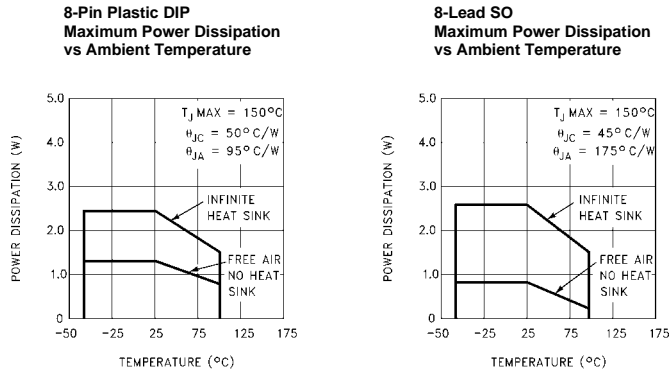

Simplified Block Diagram

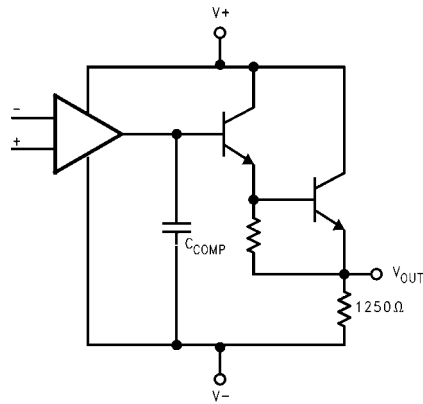

Applications Information

Product Description

The EL2221C operational amplifier is stable at a gain of 1. It is built on Elantec's proprietary complimentary bipolar process. This topology allows it to be used in a variety of applications where current mode amplifiers are not appropriate because of restrictions placed on the feedback elements. This product is especially designed for applications where high bandwidth and good video performance characteristics are desired but the higher cost of more flexible and sophisticated products are prohibitive.

Power Supplies

The EL2221C is designed to work at a supply voltage difference of 4.5V to 5.5V. It will work on any combination of \pm supplies. All electrical characteristics are measured with a 5V supply.

Output Swing vs Load

Please refer to the simplified block diagram. This amplifier provides an NPN pull-up transistor output and a passive 1250 Ω pull-down resistor to the most negative supply. In an application where the load is connected to V_{S-} the output voltage can swing to within 200 mV of V_{S-} .

Output Drive Capability

This device does not have short circuit protection. Each output is capable of than 100 mA into a shorted output. Care must be used in the design to limit the output current with a series resistor.

Single 5 Volt Supply Video Cable Driver

These amplifiers may be used as a direct coupled video cable driver with a gain of 2. With a 75 Ω back matching resistor driving a terminated 75 Ω cable the output at the cable load will be original video level (1V NTSC). The best operating mode is with direct coupling. The input signal must be offset to keep the entire signal within the range of the amplifier. The required offset voltage can be set with a resistor divider and a bypass capacitor in the video path (*Figure 1*). The input DC offset should be between .3V and .5V. With $R_A=68K$ and $R_B=4.7K$ the input offset will be .32V. Since these amplifiers require a DC load at their outputs it is good design practice to add a 250 Ω resistor to ground directly at the amplifier output. Then if the 75 Ω cable termination resistor were inadvertently removed there would still be an output signal. The values in figure 1 give an output range of 0V to 2.6V

Output capacitive coupling also has some restrictions. These amplifiers require a DC load at their outputs. A 75 Ω back matching resistor to a cable and a 75 Ω load to ground at the end of the cable provide a 150 Ω DC load. But output capacitive coupling opens this DC path so an extra pulldown resistor on the amplifier output to ground is required. Figure 4 shows a 250 Ω resistor. Capacitively coupling the output will require that we shift the output offset voltage higher than in the direct coupled case. Using $R_A=43K$ and $R_B=4.7K$ will make the quiescent output offset voltage about 1V. The output dynamic range will be .6V to 3V.

EL2221C

Dual, Low Cost, Gain of 2, Video Op Amp

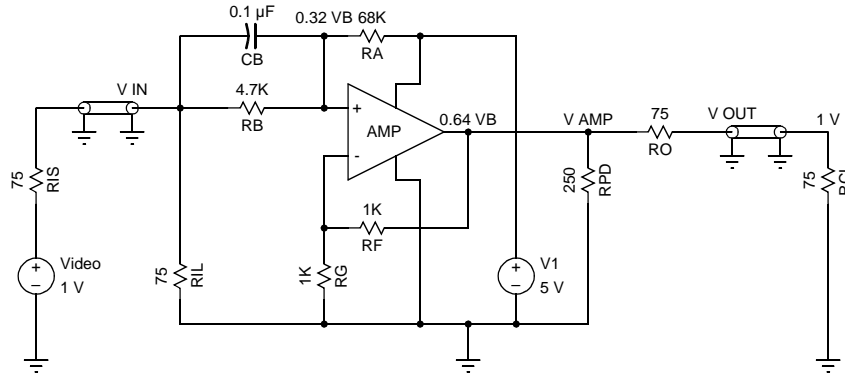

Figure 1.

Input capacitive coupling will increase the needed dynamic range of the amplifier. The standard NTSC video signal is 1V peak to peak plus 143 mV for the color AC peak. The video signal is made up of the -286 mV sync pulse plus the 714 mV picture signal which may vary from 0V to 714 mV. The video signal average value for a black picture is about 28 mV (Figure 2) and with a white picture level is about 583 mV (Figure 3). This gives a maximum change in average value of about

555 mV. A direct coupled amplifier with an standard NTSC video signal needs a dynamic range of 1.143V. But with input capacitance coupling the dynamic range requirements are the sum of the 1.143V video plus the average picture value change of 0.555V or 1.698V_{p-p}. At a gain of two this doubles to 3.394V. These amplifiers do not have this much dynamic range so a gain of less than 2 must be used to avoid waveform compression under all conditions.

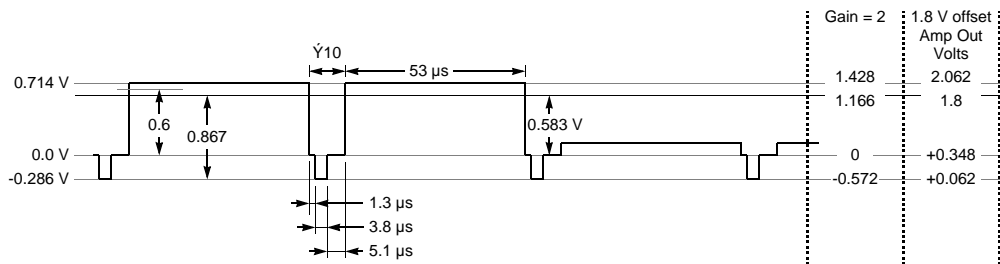
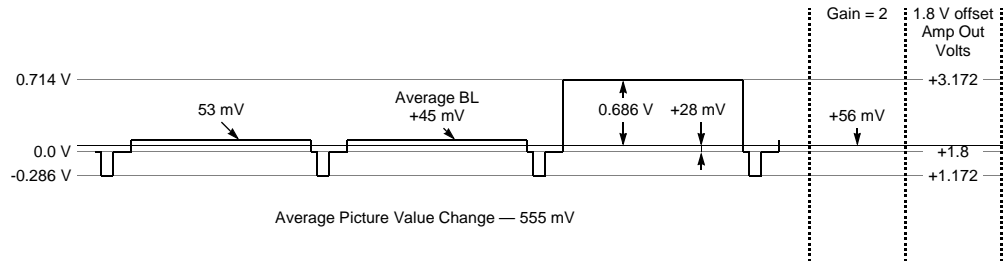

Figure 2. White Level Video

**Figure 3. Black Level Video**

Capacitively coupling the input and output is worse than a capacitor only on the input. Without any special compromises you can only take a gain of one. But if the backmatch resistor is reduced to 36Ω , reducing the output range requirement 25% and the output offset is shifted to 2.1V you can take a gain of 1.5 and have a standard NTSC 1V at the 75Ω load.

A simple transistor, capacitor and resistor sync tip clamp may be used when the input is already AC coupled to set the sync tip to ground. This gives the input a fixed DC level and can be used like a direct coupled input. The clamp uses a PNP transistor with the collector at ground and the base has a $200\text{ K}\Omega$ resistor to 5V. The emitter connects to the amplifier input and a capacitor from the video input. The clamp functions as an inverted Beta current source for input bias current with plus inputs and a clamp to ground for minus inputs. The R_A and R_B resistors are removed for the clamp option (Figure 4).

Printed Circuit Layout

The EL2221C is well behaved, and easy to apply in most applications. However, a few simple techniques will help assure rapid, high quality results. As with any high frequency device, good PCB layout is necessary for optimum performance. Ground-plane construction is highly recommended, as is good power supply bypassing. A $0.1\ \mu\text{F}$ ceramic capacitor is recommended for bypassing both supplies. Lead lengths should be as short as possible, and bypass capacitors should be as close to the device pins as possible. For good AC performance, parasitic capacitances should be kept to a minimum at both inputs and at the output. Resistor values should be kept under $5\text{ K}\Omega$ because of the RC time constants associated with the parasitic capacitance. Metal-film and carbon resistors are both acceptable, use of wire-wound resistors is not recommended because of their parasitic inductance. Similarly, capacitors should be low-inductance for best performance.

EL2221C

Dual, Low Cost, Gain of 2, Video Op Amp

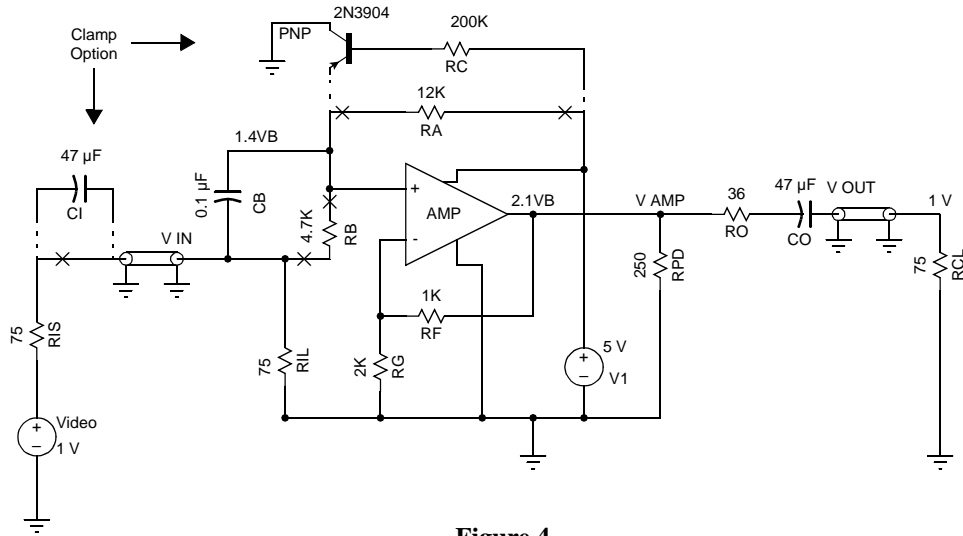
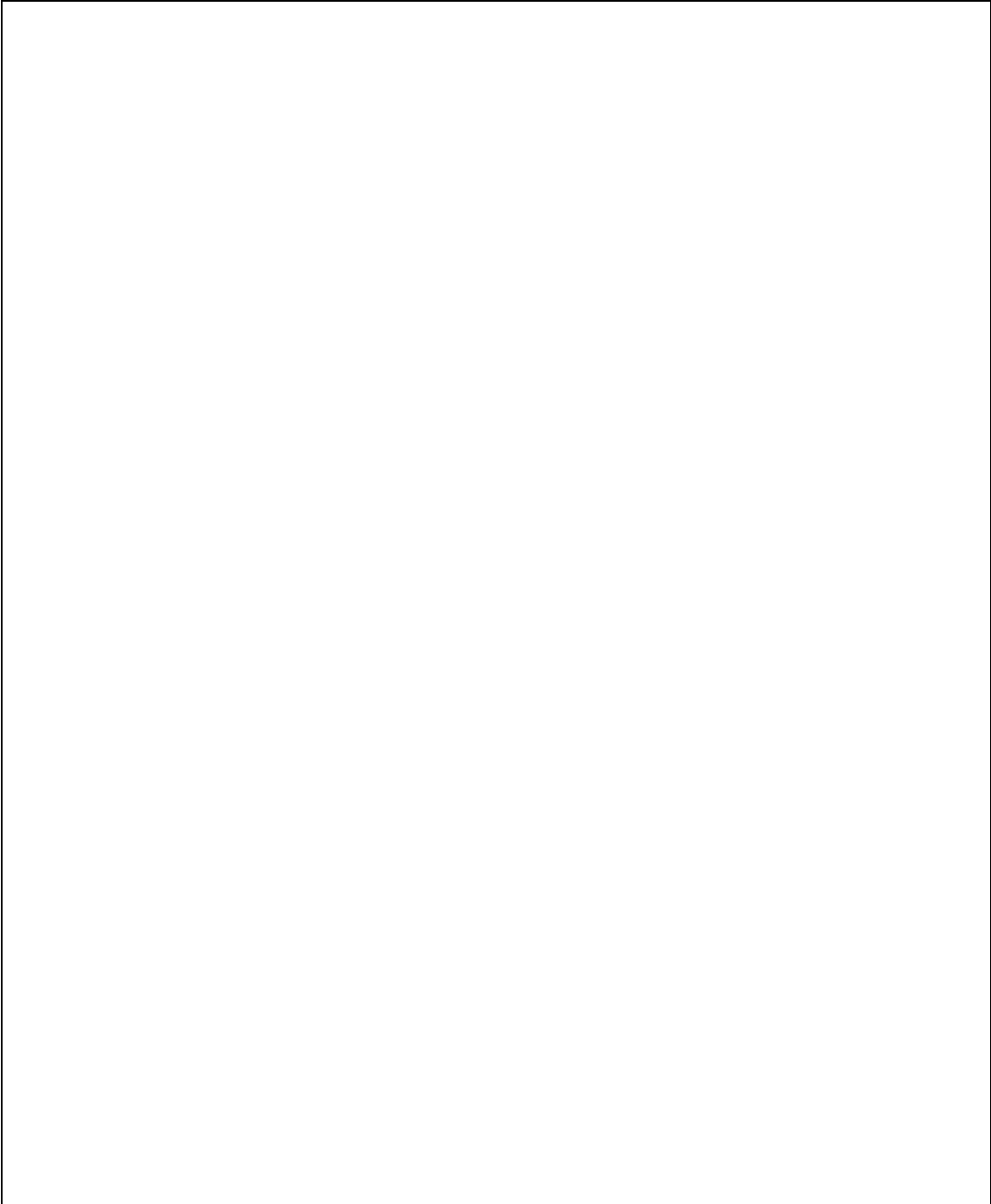

Figure 4.

EL2221C

Dual, Low Cost, Gain of 2, Video Op Amp

EL2221C



EL2221C

Dual, Low Cost, Gain of 2, Video Op Amp

General Disclaimer

Specifications contained in this data sheet are in effect as of the publication date shown. Elantec, Inc. reserves the right to make changes in the circuitry or specifications contained herein at any time without notice. Elantec, Inc. assumes no responsibility for the use of any circuits described herein and makes no representations that they are free from patent infringement.

élantec

HIGH PERFORMANCE ANALOG INTEGRATED CIRCUITS

Elantec, Inc.

1996 Tarob Court
Milpitas, CA 95035
Telephone: (408) 945-1323
(800) 333-6314
Fax: (408) 945-9305
European Office: 44-71-482-4596

WARNING - Life Support Policy

Elantec, Inc. products are not authorized for and should not be used within Life Support Systems without the specific written consent of Elantec, Inc. Life Support systems are equipment intended to support or sustain life and whose failure to perform when properly used in accordance with instructions provided can be reasonably expected to result in significant personal injury or death. Users contemplating application of Elantec, Inc. Products in Life Support Systems are requested to contact Elantec, Inc. factory headquarters to establish suitable terms & conditions for these applications. Elantec, Inc.'s warranty is limited to replacement of defective components and does not cover injury to persons or property or other consequential damages.