

January 1996

Features

- Devices QML Qualified in Accordance with MIL-PRF-38535
- Detailed Electrical and Screening Requirements are Contained in SMD# 5962-96717 and Harris' QM Plan
- 1.25 Micron Radiation Hardened SOS CMOS
- Total Dose >300K RAD (Si)
- Single Event Upset (SEU) Immunity: <math> < 1 \times 10^{-10}</math> Errors/Bit/Day (Typ)
- SEU LET Threshold >100 MEV-cm²/mg
- Dose Rate Upset >10¹¹ RAD (Si)/s, 20ns Pulse
- Dose Rate Survivability >10¹² RAD (Si)/s, 20ns Pulse
- Latch-Up Free Under Any Conditions
- Military Temperature Range -55°C to +125°C
- Significant Power Reduction Compared to ALSTTL Logic
- DC Operating Voltage Range 4.5V to 5.5V
- Input Logic Levels
 - VIL = 0.8V Max
 - VIH = VCC/2 Min
- Input Current ≤ 1μA at VOL, VOH
- Fast Propagation Delay 17.5ns (Max), 12ns (Typ)

Description

The Harris ACTS240MS is a Radiation Hardened High Reliability, High-Speed CMOS/SOS having two active low enable inputs.

The ACTS240MS utilizes advanced CMOS/SOS technology to achieve high-speed operation. This device is a member of a radiation hardened, high-speed, CMOS/SOS Logic Family.

The ACTS240MS is supplied in a 20 lead Ceramic Flatpack (K suffix) or a Dual-In-Line Ceramic Package (D suffix).

Pinouts

20 PIN CERAMIC DUAL-IN-LINE
MIL-STD-1835 DESIGNATOR CDIP2-T20,
LEAD FINISH C
TOP VIEW

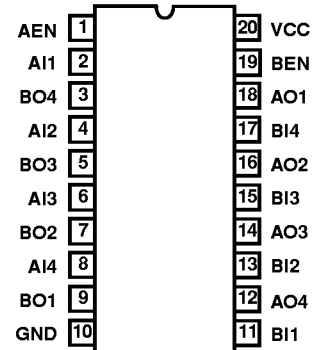

20 PIN CERAMIC FLATPACK
MIL-STD-1835 DESIGNATOR CDFP4-F20,
LEAD FINISH C
TOP VIEW

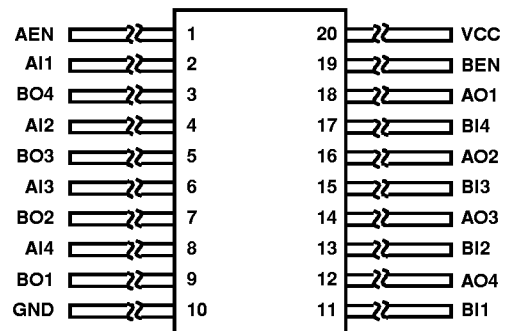

Ordering Information

PART NUMBER	TEMPERATURE RANGE	SCREENING LEVEL	PACKAGE
5962F9671701VRC	-55°C to +125°C	MIL-PRF-38535 Class V	20 Lead SBDIP
5962F9671701VXC	-55°C to +125°C	MIL-PRF-38535 Class V	20 Lead Ceramic Flatpack
ACTS240D/Sample	25°C	Sample	20 Lead SBDIP
ACTS240K/Sample	25°C	Sample	20 Lead Ceramic Flatpack
ACTS240HMSR	25°C	Die	Die

ACTS240MS

Functional Diagram

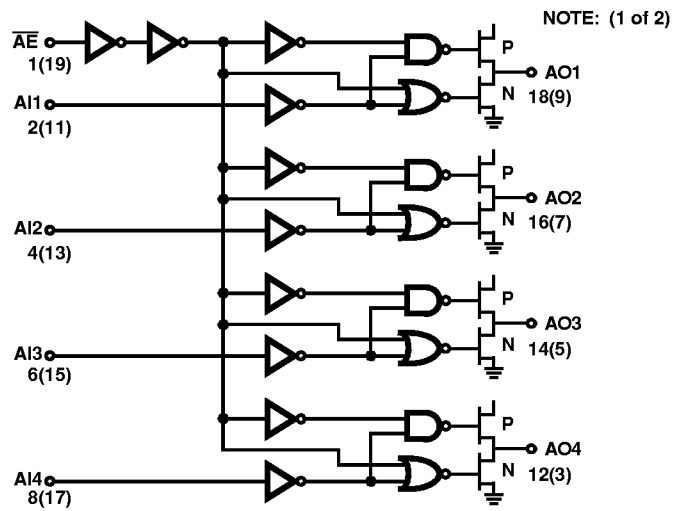

TRUTH TABLE

INPUTS		OUTPUT
$\overline{AEn}, \overline{BEn}$	AIn, BIn	AOn, BOn
L	L	H
L	H	L
H	X	Z

NOTE: H = High Voltage Level, L = Low Voltage Level,
X = Immaterial, Z = High Impedance

ACTS240MS

Die Characteristics

DIE DIMENSIONS:

100 mils x 100 mils
2.54mm x 2.54mm

METALLIZATION:

Type: AlSi
Metal 1 Thickness: $7.125\text{k}\text{\AA} \pm 1.125\text{k}\text{\AA}$
Metal 2 Thickness: $9\text{k}\text{\AA} \pm 1\text{k}\text{\AA}$

GLASSIVATION:

Type: SiO_2
Thickness: $8\text{k}\text{\AA} \pm 1\text{k}\text{\AA}$

WORST CASE CURRENT DENSITY:

$< 2.0 \times 10^5 \text{A/cm}^2$

BOND PAD SIZE:

$110\mu\text{m} \times 110\mu\text{m}$
4.4 mils x 4.4 mils

Metallization Mask Layout

