

SN54BCT25244, SN74BCT25244 25-Ω OCTAL BUFFERS/DRIVERS WITH 3-STATE OUTPUTS

SCBS064A – JUNE 1990 – REVISED NOVEMBER 1993

- **State-of-the-Art BiCMOS Design Significantly Reduces I_{CC}**
- **ESD Protection Exceeds 2000 V Per MIL-STD-883C, Method 3015; Exceeds 200 V Using Machine Model (C = 200 pF, R = 0)**
- **Designed to Facilitate Incident-Wave Switching for Line Impedances of 25 Ω or Greater**
- **Distributed V_{CC} and GND Pins Minimize Noise Generated by the Simultaneous Switching of Outputs**
- **Package Options Include Plastic Small-Outline (DW) Packages, Ceramic Chip Carriers (FK) and Flatpacs (W), and Standard Plastic and Ceramic 300-mil DIPs (JT, NT)**

SN54BCT25244 ... JT OR W PACKAGE
SN74BCT25244 ... DW OR NT PACKAGE
(TOP VIEW)

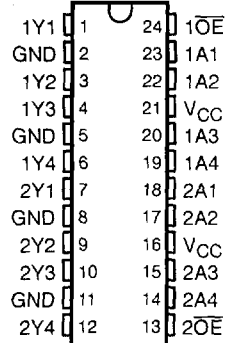

SN54BCT25244 ... FK PACKAGE
(TOP VIEW)

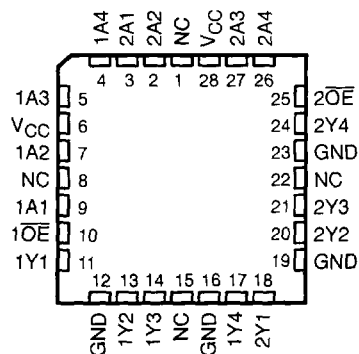

NC – No internal connection

description

These 25-Ω octal buffers and line drivers are designed specifically to improve both the performance and density of 3-state memory address drivers, clock drivers, and bus-oriented receivers and transmitters.

These buffers are capable of sinking 188-mA I_{OL} , which facilitates switching 25-Ω transmission lines on the incident wave. The distributed V_{CC} and GND pins minimize switching noise for more reliable system operation.

When the output-enable ($1\overline{OE}$ and $2\overline{OE}$) inputs are low, the device transmits data from the A inputs to the Y outputs. When $1\overline{OE}$ and $2\overline{OE}$ are high, the outputs are in the high-impedance state.

The SN54BCT25244 is characterized for operation over the full military temperature range of -55°C to 125°C. The SN74BCT25244 is characterized for operation from 0°C to 70°C.

FUNCTION TABLE
(each buffer/driver)

INPUTS		OUTPUT
\overline{OE}	A	Y
L	H	H
L	L	L
H	X	Z

PRODUCTION DATA Information is current as of publication date. Products conform to specifications per the terms of Texas Instruments standard warranty. Production processing does not necessarily include testing of all parameters.

TEXAS
INSTRUMENTS

POST OFFICE BOX 655303 • DALLAS, TEXAS 75265

Copyright © 1993, Texas Instruments Incorporated

2-163

SN54BCT25244, SN74BCT25244
25-Ω OCTAL BUFFERS/DRIVERS
WITH 3-STATE OUTPUTS

SCBS064A – JUNE 1990 – REVISED NOVEMBER 1993

logic symbol†

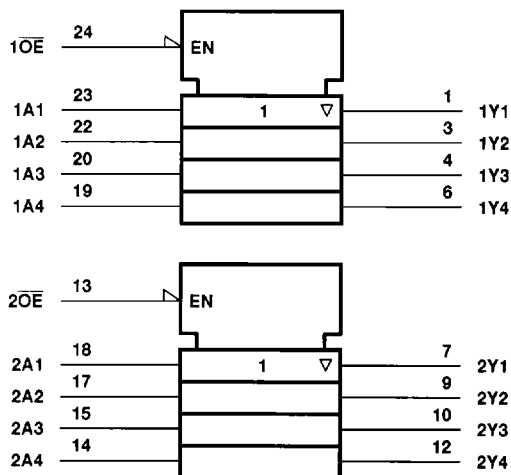

† This symbol is in accordance with ANSI/IEEE Std 91-1984 and IEC Publication 617-12.

logic diagram (positive logic)

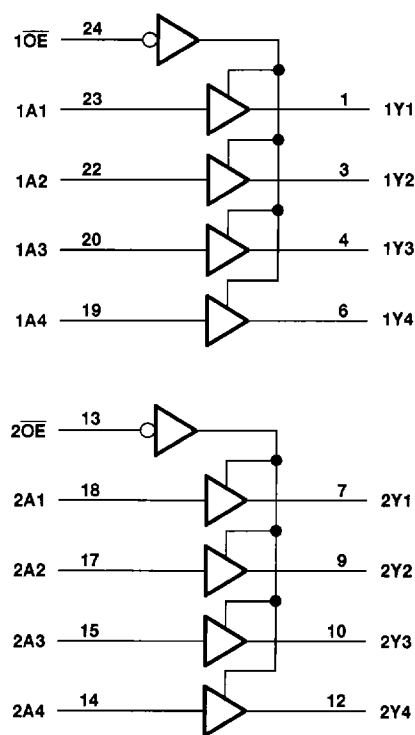

Pin numbers shown are for the DW, JT, NT, and W packages.

absolute maximum ratings over operating free-air temperature range (unless otherwise noted)‡

Supply voltage range, V_{CC}	-0.5 V to 7 V
Input voltage range, V_I (see Note 1)	-0.5 V to 7 V
Voltage range applied to any output in the disabled or power-off state, V_O	-0.5 V to 5.5 V
Voltage range applied to any output in the high state, V_O	-0.5 V to V_{CC}
Input clamp current, I_{IK} ($V_I < 0$)	-30 mA
Current into any output in the low state, I_O : SN54BCT25244	250 mA
SN74BCT25244	376 mA
Operating free-air temperature range: SN54BCT25244	-55°C to 125°C
SN74BCT25244	0°C to 70°C
Storage temperature range	-65°C to 150°C

‡ Stresses beyond those listed under "absolute maximum ratings" may cause permanent damage to the device. These are stress ratings only, and functional operation of the device at these or any other conditions beyond those indicated under "recommended operating conditions" is not implied. Exposure to absolute-maximum-rated conditions for extended periods may affect device reliability.

NOTE 1: The input and output negative-voltage ratings may be exceeded if the input and output clamp-current ratings are observed.

SN54BCT25244, SN74BCT25244
25-Ω OCTAL BUFFERS/DRIVERS
WITH 3-STATE OUTPUTS

SCBS064A – JUNE 1980 – REVISED NOVEMBER 1993

recommended operating conditions (see Note 2)

		SN54BCT25244			SN74BCT25244			UNIT
		MIN	NOM	MAX	MIN	NOM	MAX	
V _{CC}	Supply voltage	4.5	5	5.5	4.5	5	5.5	V
V _{IH}	High-level input voltage	2			2			V
V _{IL}	Low-level input voltage				0.8			V
I _{IK}	Input clamp current				-18			mA
I _{OH}	High-level output current				-53			mA
I _{OL}	Low-level output current				125			mA
T _A	Operating free-air temperature	-55			125			°C

NOTE 2: Unused or floating inputs must be held high or low.

electrical characteristics over recommended operating free-air temperature range (unless otherwise noted)

PARAMETER	TEST CONDITIONS	SN54BCT25244			SN74BCT25244			UNIT
		MIN	TYP†	MAX	MIN	TYP†	MAX	
V _{IK}	V _{CC} = 4.5 V, I _I = -18 mA				-1.2			V
V _{OH}	V _{CC} = 4.75 V, I _{OH} = -3 mA				2.7			V
	V _{CC} = 4.5 V, I _{OH} = -53 mA	2						
V _{OL}	V _{CC} = 4.5 V, I _{OL} = 94 mA				0.38			V
					0.55			
					0.42			
					0.55			
					0.7			
I _I	V _{CC} = 5.5 V, V _I = 5.5 V				0.1			mA
I _{IH}	V _{CC} = 5.5 V, V _I = 2.7 V				20			μA
I _{IL}	V _{CC} = 5.5 V, V _I = 0.5 V				-0.6			mA
I _{OZH}	V _{CC} = 5.5 V, V _O = 2.7 V				50			μA
I _{OZL}	V _{CC} = 5.5 V, V _O = 0.5 V				-50			μA
I _{CCL}	V _{CC} = 5.5 V, Outputs open	90			119			mA
I _{CCH}	V _{CC} = 5.5 V, Outputs open	59			78			mA
I _{CCZ}	V _{CC} = 5.5 V, Outputs open	7			11			mA
C _i	V _{CC} = 5 V, V _I = 2.5 V or 0.5 V	5.5			5.5			pF
C _o	V _{CC} = 5 V, V _O = 2.5 V or 0.5 V	17			17			pF

† All typical values are at V_{CC} = 5 V, T_A = 25°C.

switching characteristics over recommended ranges of supply voltage and operating free-air temperature, C_L = 50 pF (unless otherwise noted) (see Note 3)

PARAMETER	FROM (INPUT)	TO (OUTPUT)	V _{CC} = 5 V, T _A = 25°C			SN54BCT25244		SN74BCT25244		UNIT
			MIN	TYP	MAX	MIN	MAX	MIN	MAX	
t _{PLH}	A	Y	1	3.2	4.9	1	5.6	1	5.5	ns
t _{PHL}			2	4	5.6	2	6.3	2	6	
t _{PZH}	OE	Y	3.2	5.6	8.5	3.2	9.7	3.2	9.3	ns
t _{PZL}			3.7	6.3	9.2	3.7	10.4	3.7	10.2	
t _{PHZ}	OE	Y	1.6	3.6	5.5	1.6	6.5	1.6	6.3	ns
t _{PLZ}			3.1	5.3	7.8	3.1	9.5	3.1	8.4	

NOTE 3: Load circuits and voltage waveforms are shown in Section 1.



POST OFFICE BOX 655303 • DALLAS, TEXAS 75265