

SN54BCT241, SN74BCT241 OCTAL BUFFERS/DRIVERS WITH 3-STATE OUTPUTS

SCBS005D – OCTOBER 1987 – REVISED APRIL 1994

- State-of-the-Art BICMOS Design Significantly Reduces I_{CCZ}
- ESD Protection Exceeds 2000 V Per MIL-STD-883C, Method 3015
- 3-State Outputs Drive Bus Lines or Buffer Memory Address Registers
- Package Options Include Plastic Small-Outline (DW) and Shrink Small-Outline (DB) Packages, Ceramic Chip Carriers (FK) and Flatpacks (W), and Standard Plastic and Ceramic 300-mil DIPs (J, N)

description

These octal buffers and line drivers are designed specifically to improve both the performance and density of 3-state memory address drivers, clock drivers, and bus-oriented receivers and transmitters. Taken together with the 'BCT240 and 'BCT244, these devices provide the choice of selected combinations of inverting and noninverting outputs, symmetrical \overline{OE} (active-low output-enable) inputs, and complementary OE and \overline{OE} inputs.

The SN54BCT241 is characterized for operation over the full military temperature range of -55°C to 125°C . The SN74BCT241 is characterized for operation from 0°C to 70°C .

SN54BCT241 ... J OR W PACKAGE
SN74BCT241 ... DB, DW OR N PACKAGE
(TOP VIEW)

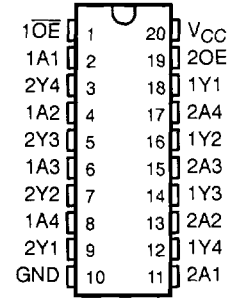

SN54BCT241 ... FK PACKAGE
(TOP VIEW)

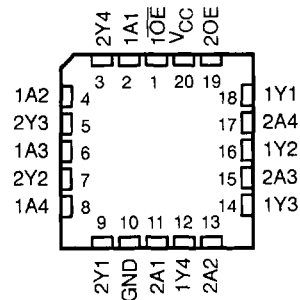

FUNCTION TABLES

INPUTS		OUTPUT
$\overline{1OE}$	1A	1Y
L	H	H
L	L	L
H	X	Z

INPUTS		OUTPUT
2OE	2A	2Y
H	H	H
H	L	L
L	X	Z

PRODUCTION DATA Information is current as of publication date. Products conform to specifications per the terms of Texas Instruments standard warranty. Production processing does not necessarily include testing of all parameters.

 **TEXAS
INSTRUMENTS**

POST OFFICE BOX 655303 • DALLAS, TEXAS 75265

Copyright © 1994, Texas Instruments Incorporated

2-15

SN54BCT241, SN74BCT241
OCTAL BUFFERS/DRIVERS
WITH 3-STATE OUTPUTS

SCBS005D – OCTOBER 1987 – REVISED APRIL 1994

logic symbol†

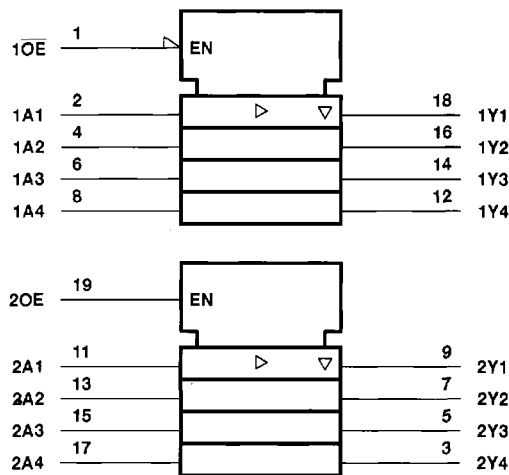

† This symbol is in accordance with ANSI/IEEE Std 91-1984 and IEC Publication 617-12.

logic diagram (positive logic)

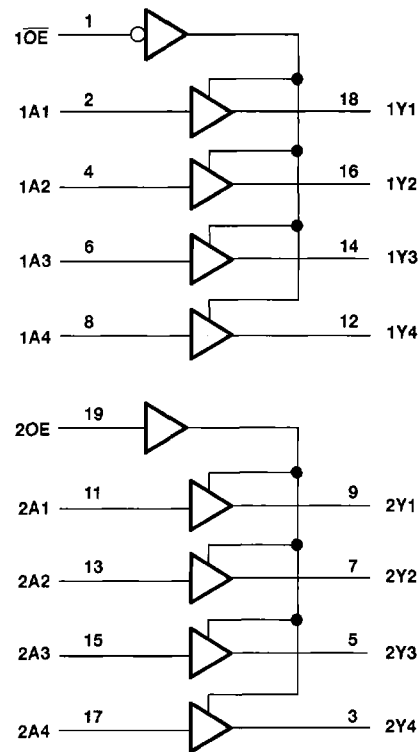

absolute maximum ratings over operating free-air temperature range (unless otherwise noted)‡

Supply voltage range, V_{CC}	- 0.5 V to 7 V
Input voltage range, V_I (see Note 1)	- 0.5 V to 7 V
Voltage range applied to any output in the disabled or power-off state, V_O	- 0.5 V to 5.5 V
Voltage range applied to any output in the high state, V_O	- 0.5 V to V_{CC}
Input clamp current, I_{IK}	- 30 mA
Current into any output in the low state: SN54BCT241	96 mA
SN74BCT241	128 mA
Operating free-air temperature range: SN54BCT241	- 55°C to 125°C
SN74BCT241	0°C to 70°C
Storage temperature range	- 65°C to 150°C

‡ Stresses beyond those listed under "absolute maximum ratings" may cause permanent damage to the device. These are stress ratings only, and functional operation of the device at these or any other conditions beyond those indicated under "recommended operating conditions" is not implied. Exposure to absolute-maximum-rated conditions for extended periods may affect device reliability.

NOTE 1: The input and output voltage ratings may be exceeded if the input and output current ratings are observed.



POST OFFICE BOX 655303 • DALLAS, TEXAS 75265

**SN54BCT241, SN74BCT241
OCTAL BUFFERS/DRIVERS
WITH 3-STATE OUTPUTS**

SCBS005D – OCTOBER 1987 – REVISED APRIL 1994

recommended operating conditions

		SN54BCT241			SN74BCT241			UNIT
		MIN	NOM	MAX	MIN	NOM	MAX	
V _{CC}	Supply voltage	4.5	5	5.5	4.5	5	5.5	V
V _{IH}	High-level input voltage	2			2			V
V _{IL}	Low-level input voltage			0.8			0.8	V
I _{IK}	Input clamp current			-18			-18	mA
I _{OH}	High-level output current			-12			-15	mA
I _{OL}	Low-level output current			48			64	mA
T _A	Operating free-air temperature	-55		125	0		70	°C

electrical characteristics over recommended operating free-air temperature range (unless otherwise noted)

PARAMETER	TEST CONDITIONS		SN54BCT241			SN74BCT241			UNIT
			MIN	TYP†	MAX	MIN	TYP†	MAX	
V _{IK}	V _{CC} = 4.5 V, I _I = -18 mA				-1.2			-1.2	V
V _{OH}	V _{CC} = 4.5 V	I _{OH} = -3 mA	2.4	3.3		2.4	3.3		V
		I _{OH} = -12 mA	2	3.2					
		I _{OH} = -15 mA				2	3.1		
V _{OL}	V _{CC} = 4.5 V	I _{OL} = 48 mA	0.38	0.55					V
		I _{OL} = 64 mA				0.42	0.55		
I _I	V _{CC} = 5.5 V, V _I = 7 V			0.1			0.1	mA	
I _{IH}	V _{CC} = 5.5 V, V _I = 2.7 V			20			20	μA	
I _{IL}	V _{CC} = 5.5 V, V _I = 0.5 V	1OE or 2OE			-1			-1	mA
		Any A input			-1.6			-1.6	
I _{OZH}	V _{CC} = 5.5 V, V _O = 2.7 V			50			50	μA	
I _{OZL}	V _{CC} = 5.5 V, V _O = 0.5 V			-50			-50	μA	
I _{OS} ‡	V _{CC} = 5.5 V, V _O = 0			-100		-225	-100	-225	mA
I _{CCH}	V _{CC} = 5.5 V, Outputs open			23	43		23	43	mA
I _{CCL}	V _{CC} = 5.5 V, Outputs open			53	85		53	85	mA
I _{CCZ}	V _{CC} = 5.5 V, Outputs open			4	10		4	10	mA
C _i	V _{CC} = 5 V, V _I = 2.5 V or 0.5 V			6			6		pF
C _o	V _{CC} = 5 V, V _O = 2.5 V or 0.5 V			11			11		pF

† All typical values are at V_{CC} = 5 V, T_A = 25°C.

‡ Not more than one output should be tested at a time, and the duration of the test should not exceed one second.



POST OFFICE BOX 655303 • DALLAS, TEXAS 75265

SN54BCT241, SN74BCT241
OCTAL BUFFERS/DRIVERS
WITH 3-STATE OUTPUTS

SCBS005D – OCTOBER 1987 – REVISED APRIL 1994

switching characteristics (see Note 2)

PARAMETER	FROM (INPUT)	TO (OUTPUT)	V _{CC} = 5 V, C _L = 50 pF, R ₁ = 500 Ω, R ₂ = 500 Ω, T _A = 25°C			V _{CC} = 4.5 V to 5.5 V, C _L = 50 pF, R ₁ = 500 Ω, R ₂ = 500 Ω, T _A = MIN to MAX†				UNIT
			BCT241			SN54BCT241		SN74BCT241		
			MIN	TYP	MAX	MIN	MAX	MIN	MAX	
t _{PLH}	A	Y	0.5	2.5	4.5	0.5	5.2	0.5	4.9	ns
t _{PHL}			1	3	5.4	1	6.3	1	5.9	
t _{PZH}	OE or OE	Y	1	5.7	7.8	1	9.1	1	8.7	ns
t _{PZL}			1	5.2	8.6	1	10	1	9.4	
t _{PHZ}	OE or OE	Y	1	5.8	6.8	1	8.4	1	8.1	ns
t _{PLZ}			1	7	8.1	1	11	1	9.9	

† For conditions shown as MIN or MAX, use the appropriate value specified under recommended operating conditions.

NOTE 2: Load circuits and voltage waveforms are shown in Section 1.



POST OFFICE BOX 655303 • DALLAS, TEXAS 75265