



High Speed CMOS 8-Bit Bus Interface Register Tranceivers

QS54/74FCT646T
QS54/74FCT648T

QS54/74FCT2646T
QS54/74FCT2648T*

FEATURES/BENEFITS

- Pin and function compatible to the 74F646/8 74FCT646/8 and 74FCT646T/8T
- CMOS power levels: <7.5 mW static
- Available in DIP, SOIC, QSOP, ZIP, HQSOP
- Undershoot clamp diodes on all inputs
- TTL-compatible input and output levels
- Ground bounce controlled outputs
- Reduced output swing of 0-3.5V
- Military product compliant to MIL-STD-883

3

FCT-T 646T, 648T

- JEDEC-FCT spec compatible
- Fastest CMOS logic family available
- Std, A, C, and D speed grades with 4.8 ns t_{PD} for D
- $I_{OL} = 64$ mA Com., 48 mA Mil.

FCT-T 2646T, 2648T

- Built-in 25Ω series resistor outputs reduce reflection and other system noise
- Std, A, C, and D speed grades with 4.8 ns t_{PD} for D
- $I_{OL} = 12$ mA Com.

DESCRIPTION

The QSFCT646T/648T and QSFCT2646T/648T are 8-bit high-speed CMOS TTL-compatible registered bus transceivers with three-state outputs that are ideal for driving high capacitance loads such as memory and address buses. The 2646/8 devices are 25Ω resistor output versions useful for driving transmission lines and reducing system noise. The 2646 series parts can replace the 646 series to reduce noise in an existing design. All inputs have clamp diodes for undershoot noise suppression. All outputs have ground bounce suppression (see QSI Application Note AN-001), and outputs will not load an active bus when Vcc is removed from the device.

FUNCTIONAL BLOCK DIAGRAM

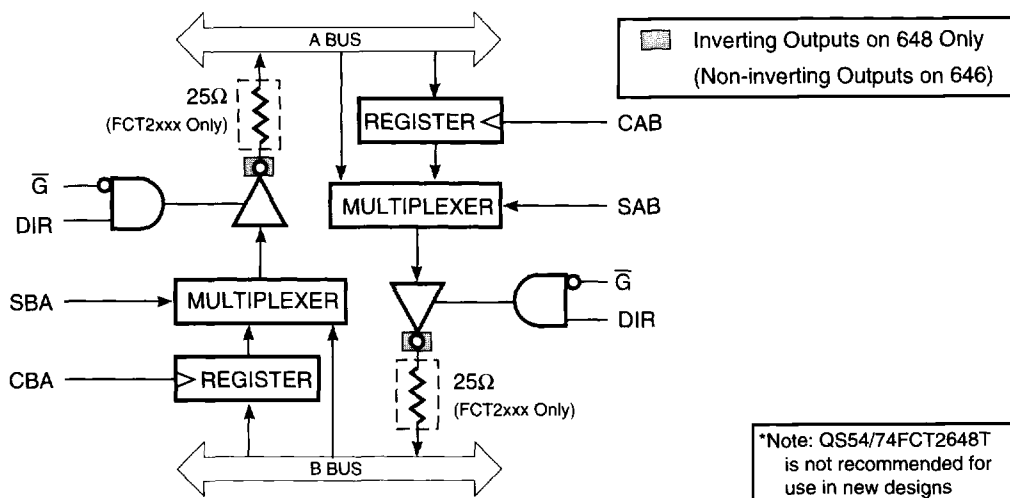

PIN CONFIGURATIONS (All Pins Top View)

PDIP, SOIC, QSOP, HQSOP

ZIP

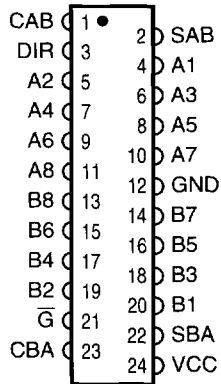
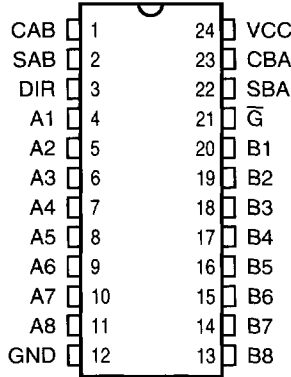

PIN DESCRIPTION

Name	I/O	Description
A8-A1	I/O	A Bus
B8-B1	I/O	B Bus
CAB	I	Clock A to Register
CBA	I	Clock B to Register
SAB	I	A Bus or Reg to B
SBA	I	B Bus or Reg to A
DIR	I	Direction, A → B or B → A
\bar{G}	I	Output Enable

FUNCTION TABLE

Inputs						Outputs		Function	
\bar{G}	DIR	CAB	CBA	SAB	SBA	A8-A1	B8-B1	646/2646	648/2648
H	—	—	—	—	—	Hi-Z	Hi-Z	Disabled	Disabled
L	L	—	—	—	—	A	Hi-Z	Output A	Output A
L	H	—	—	—	—	Hi-Z	B	Output B	Output B
—	—	↑	—	—	—	—	—	Load A Register	Load A Register
—	—	—	↑	—	—	—	—	Load B Register	Load B Register
—	—	—	—	L	—	—	—	A Bus → B Bus	\bar{A} Bus → B Bus
—	—	—	—	H	—	—	—	A Reg → B Bus	\bar{A} Reg → B Bus
—	—	—	—	—	L	—	—	B Bus → A Bus	\bar{B} Bus → A Bus
—	—	—	—	—	H	—	—	B Reg → A Bus	\bar{B} Reg → A Bus

ABSOLUTE MAXIMUM RATINGS

Supply Voltage to Ground	-0.5V to +7.0V
DC Output Voltage V_{OUT}	-0.5V to +7.0V
DC Input Voltage V_{IN}	-0.5V to +7.0V
AC Input Voltage (for a pulse width ≤ 20 ns)	-3.0V
DC Input Diode Current with $V_{IN} < 0$	-20 mA
DC Output Diode Current with $V_{OUT} < 0$	-50 mA
DC Output Current Max. Sink Current/Pin	120 mA
Maximum Power Dissipation	0.5 watts
T_{STG} Storage Temperature	-65° to +150°C

Note: Stresses greater than those listed under ABSOLUTE MAXIMUM RATINGS may cause permanent damage to QSI devices that result in functional or reliability type failures.

CAPACITANCE

$T_A = 25^\circ\text{C}$, $f = 1$ MHz, $V_{IN} = 0\text{V}$, $V_{OUT} = 0\text{V}$

Pins	SOIC	QSOP	PDIP	ZIP	Unit
—	4	4	5	7	pF
—	6	6	7	9	pF
1-11, 13-23	8	8	9	10	pF

Note: Capacitance is characterized but not tested.



POWER SUPPLY CHARACTERISTICS

Symbol	Parameter	Test Conditions ⁽¹⁾	Min	Max	Unit
I_{CC}	Quiescent Power Supply Current	$V_{CC} = \text{Max.}$, freq = 0 $0\text{V} \leq V_{IN} \leq 0.2\text{V}$ or $V_{CC} - 0.2\text{V} \leq V_{IN} \leq V_{CC}$	—	1.5	mA
ΔI_{CC}	Supply Current per Input @ TTL HIGH	$V_{CC} = \text{Max.}$, $V_{IN} = 3.4\text{V}$, freq = 0 ⁽²⁾	—	2.0	mA
Q_{CCD}	Supply Current per Input per MHz	$V_{CC} = \text{Max.}$, Outputs Open and Enabled One Bit Toggling @ 50% Duty Cycle Other Inputs at GND or V_{CC} ^(3,4)	—	0.25	mA/ MHz

Notes:

1. For conditions shown as Min. or Max., use the appropriate values specified under DC specifications.
2. Per TTL driven input ($V_{IN} = 3.4\text{V}$).
3. For flip-flops, Q_{CCD} is measured by switching one of the data input pins so that the output changes every clock cycle. This is a measurement of device power consumption only and does not include power to drive load capacitance or tester capacitance. This parameter is guaranteed by design but not tested.
4. I_C can be computed using the above parameters as explained in the Technical Overview section.

QSFCT646T, 648T, 2646T, 2648T

DC ELECTRICAL CHARACTERISTICS OVER OPERATING RANGE

Commercial $T_A = 0^{\circ}\text{C}$ to 70°C , $V_{CC} = 5.0\text{V} \pm 5\%$

Military $T_A = -55^{\circ}\text{C}$ to 125°C , $V_{CC} = 5.0\text{V} \pm 10\%$

Symbol	Parameter	Test Conditions	Min	Typ ⁽¹⁾	Max	Unit
V_{IH}	Input HIGH Voltage	Logic HIGH for All Inputs	2.0	—	—	V
V_{IL}	Input LOW Voltage	Logic LOW for All Inputs	—	—	0.8	V
ΔV_T	Input Hysteresis	$V_{TLH} - V_{THL}$ for All Inputs	—	0.2	—	V
$ I_{IH} $ $ I_{IL} $	Input Current Input HIGH or LOW	$V_{CC} = \text{Max.}, 0 \leq V_{IN} < V_{CC}$	—	—	5	μA
$ I_{OZ} $	Off-State Output Current (Hi-Z)	$V_{CC} = \text{Max.}, 0 \leq V_{IN} \leq V_{CC}$	—	—	5	μA
I_{OS}	Short Circuit Current (FCTXXX)	$V_{CC} = \text{Max.}, V_{OUT} = \text{GND}^{(2,3)}$	-60	—	—	mA
I_{OR}	Current Drive (FCT2XXX)	$V_{CC} = \text{Max.}, V_{OUT} = 2.0\text{V}^{(3)}$	50	—	—	mA
V_{IC}	Input Clamp Voltage	$V_{CC} = \text{Min.}, I_{IN} = -18 \text{ mA}, T_A = 25^{\circ}\text{C}^{(3)}$	—	-0.7	-1.2	V
V_{OH}	Output HIGH Voltage	$V_{CC} = \text{Min.}$ $I_{OH} = -12 \text{ mA (MIL)}$ $I_{OH} = -15 \text{ mA (COM)}$	2.4 2.4	— —	— —	V
V_{OL}	Output LOW Voltage (FCTXXX)	$V_{CC} = \text{Min.}$ $I_{OL} = 48 \text{ mA (MIL)}$ $I_{OL} = 64 \text{ mA (COM)}$	— —	— —	0.55 0.55	V
V_{OL}	Output LOW Voltage (FCT2XXX- 25 Ω)	$V_{CC} = \text{Min.}$ $I_{OL} = 12 \text{ mA (MIL)}$ $I_{OL} = 12 \text{ mA (COM)}$	— —	— —	0.50 0.50	V
R_{OUT}	Output Resistance (FCT2XXX- 25 Ω)	$V_{CC} = \text{Min.}$ $I_{OL} = 12 \text{ mA (MIL)}$ $I_{OL} = 12 \text{ mA (COM)}$	— 20	25 28	— 40	Ω

Notes:

1. Typical values indicate $V_{CC} = 5.0\text{V}$ and $T_A = 25^{\circ}\text{C}$.
2. Not more than one output should be shorted and the duration is ≤ 1 second.
3. These parameters are guaranteed by design but not tested.

QSFACT646T, 648T, 2646T, 2648T

SWITCHING CHARACTERISTICS OVER OPERATING RANGE

Commercial TA = 0°C to 70°C, Vcc = 5.0V ± 5%

Military TA = -55°C to 125°C, Vcc = 5.0V ± 10%

CLOAD = 50 pF, RLOAD = 500Ω unless otherwise noted.

Symbol	Description(1)		646 2646		646A 2646A		646C 2646C		646D 2646D		Unit
			Min	Max	Min	Max	Min	Max	Min	Max	
tPHLB	Bus to Bus	Com	2.0	9.0	2.0	6.3	1.5	5.4	1.5	4.8	ns
tPLHB	Delay, 646	Mil	2.0	11	2.0	7.7	1.5	6.0	—	—	
tPHLB	Bus to Bus	Com	2.0	9.0	2.0	6.3	1.5	5.4	1.5	4.8	ns
tPLHB	Delay, 2646	Mil	2.0	11	2.0	7.7	1.5	6.0	—	—	
tpZH	Output Enable	Com	2.0	14	2.0	9.8	1.5	7.8	1.5	7.3	ns
tpZL	Time, 646	Mil	2.0	15	2.0	10.5	1.5	8.9	—	—	
tpZH	Output Enable	Com	2.0	14	2.0	9.8	1.5	7.8	1.5	7.3	ns
tpZL	Time, 2646	Mil	2.0	15	2.0	10.5	1.5	8.9	—	—	
tPHZ	Output Disable	Com(2)	2.0	9.0	2.0	6.3	1.5	6.3	1.5	6.3	ns
tPLZ	Time	Mil(2)	2.0	11	2.0	7.7	1.5	7.7	—	—	
tPHLC	Clock to Bus	Com	2.0	9.0	2.0	6.3	1.5	5.7	1.5	5.2	ns
tPLHC	Delay, 646	Mil	2.0	10	2.0	7.0	1.5	6.3	—	—	
tPHLC	Clock to Bus	Com	2.0	9.0	2.0	6.3	1.5	5.7	1.5	5.2	ns
tPLHC	Delay, 2646	Mil	2.0	10	2.0	7.0	1.5	6.3	—	—	
tPHLS	SBA/SAB to Bus	Com	2.0	11	2.0	7.7	1.5	6.2	1.5	5.8	ns
tPLHS	Delay, 646	Mil	2.0	12	2.0	8.4	1.5	7.0	—	—	
tPHLS	SBA/SAB to Bus	Com	2.0	11	2.0	7.7	1.5	6.2	1.5	5.8	ns
tPLHS	Delay, 2646	Mil	2.0	12	2.0	8.4	1.5	7.0	—	—	
ts	Data Setup Time	Com	4.0	—	2.0	—	2.0	—	2.0	—	ns
		Mil	4.5	—	2.0	—	2.0	—	—	—	
th	Data Hold Time	Com	2.0	—	1.5	—	1.5	—	1.5	—	ns
		Mil	2.0	—	1.5	—	1.5	—	—	—	
tpWH	Clock Pulse Width	Com(2)	6.0	—	5.0	—	5.0	—	5.0	—	ns
tpWL	HIGH or LOW	Mil(2)	6.0	—	5.0	—	5.0	—	—	—	

3

Notes:

1. Minimums guaranteed but not tested for all parameters except ts and th.
2. This parameter is guaranteed by design but not tested.
3. See Test Circuit and Waveforms.

QSFACT646T, 648T, 2646T, 2648T

TIMING REQUIREMENTS OVER OPERATING RANGE

Commercial $T_A = 0^\circ\text{C}$ to 70°C , $V_{CC} = 5.0\text{V} \pm 5\%$

Military $T_A = -55^\circ\text{C}$ to 125°C , $V_{CC} = 5.0\text{V} \pm 10\%$

$C_{LOAD} = 50\text{ pF}$, $R_{LOAD} = 500\Omega$ unless otherwise noted.

Symbol	Description ⁽¹⁾		648 2648		648A 2648A		648C 2648C		Unit
			Min	Max	Min	Max	Min	Max	
t _{PHLB}	Bus to Bus	Com	2.0	8.0	2.0	5.6	1.5	5.4	ns
t _{PLHB}	Delay, 648	Mil	2.0	9.0	2.0	6.3	1.5	6.0	
t _{PHLB}	Bus to Bus	Com	2.0	8.0	2.0	5.6	1.5	5.4	ns
t _{PLHB}	Delay, 2648	Mil	2.0	9.0	2.0	6.3	1.5	6.0	
t _{PZH}	Ouput Enable	Com	2.0	15	2.0	10.5	1.5	7.8	ns
t _{PZL}	Time, 648	Mil	2.0	18	2.0	12.6	1.5	8.9	
t _{PZH}	Output Enable	Com	2.0	15	2.0	10.5	1.5	7.8	ns
t _{PZL}	Time, 2648	Mil	2.0	18	2.0	12.6	1.5	8.9	
t _{PHZ}	Output Disable	Com ⁽²⁾	2.0	9.0	2.0	6.3	1.5	6.3	ns
t _{PLZ}	Time	Mil ⁽²⁾	2.0	11	2.0	7.7	1.5	7.7	
t _{PHLC}	Clock to Bus	Com	2.0	9.0	2.0	6.3	1.5	5.7	ns
t _{PLHC}	Delay, 648	Mil	2.0	10	2.0	7.0	1.5	6.3	
t _{PHLC}	Clock to Bus	Com	2.0	9.0	2.0	6.3	1.5	5.7	ns
t _{PLHC}	Delay, 2648	Mil	2.0	10	2.0	7.0	1.5	6.3	
t _{PHLS}	SBA/SAB to Bus	Com	2.0	11	2.0	7.7	1.5	6.2	ns
t _{PLHS}	Delay, 648	Mil	2.0	12	2.0	8.4	1.5	7.0	
t _{PHLS}	SBA/SAB to Bus	Com	2.0	11	2.0	7.7	1.5	6.2	ns
t _{PLHS}	Delay, 2648	Mil	2.0	12	2.0	8.4	1.5	7.0	
t _s	Data Setup Time	Com	4.0	—	2.0	—	2.0	—	ns
		Mil	4.5	—	2.0	—	2.0	—	
t _h	Data Hold Time	Com	2.0	—	1.5	—	1.5	—	ns
		Mil	2.0	—	1.5	—	1.5	—	
t _{PWH}	Clock Pulse Width	Com ⁽²⁾	6.0	—	5.0	—	5.0	—	ns
t _{PWL}	HIGH to LOW	Mil ⁽²⁾	6.0	—	5.0	—	5.0	—	

Notes:

1. Minimums guaranteed but not tested for all parameters except t_s and t_h .
2. This parameter is guaranteed by design but not tested.
3. See Test Circuit and Waveforms.