



PI3C3244

3.3V, High Bandwidth, Hot Insertion, 8-Bit, 2-Port Bus Switch

Product Features

- Near zero propagation delay
- High Bandwidth (>200 MHz)
- Rail-to-Rail 3.3V Switching
- 5V I/O Tolerant
- Fast Switching Speed - 4.5ns max.
- Permits Hot Insertion
- Pin compatible with 74 series 244 logic devices
- Packages available:
 - 20-pin 150 mil wide plastic QSOP (Q20)

Product Description

Pericom Semiconductor's PI3C series of logic circuits are produced in the Company's advanced sub micron CMOS technology, achieving industry leading performance.

The PI3C3244 features a set of 3.3V 8-bit bus switches, which is a pinout and function compatible with the P74FCT244T, 74F244, and 74ALS/AS/LS2448-bit drivers. Two enable signals (\overline{BEn}) turn the switches on similar to the enable signals of the 244. The bus switch create no additional propagation delay or ground bounce noise.

It is very useful in switching signals that have high bandwidth (>200 MHz).

Logic Block Diagram

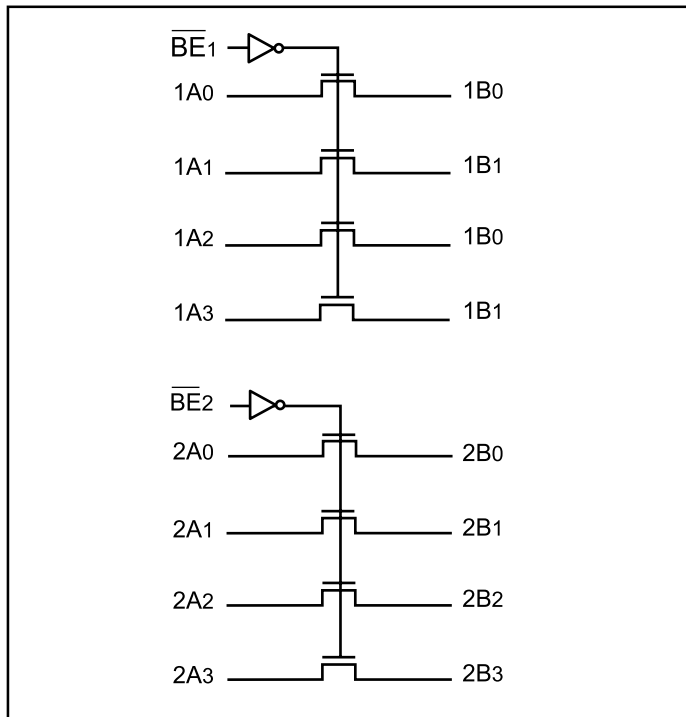

Product Pin Configuration

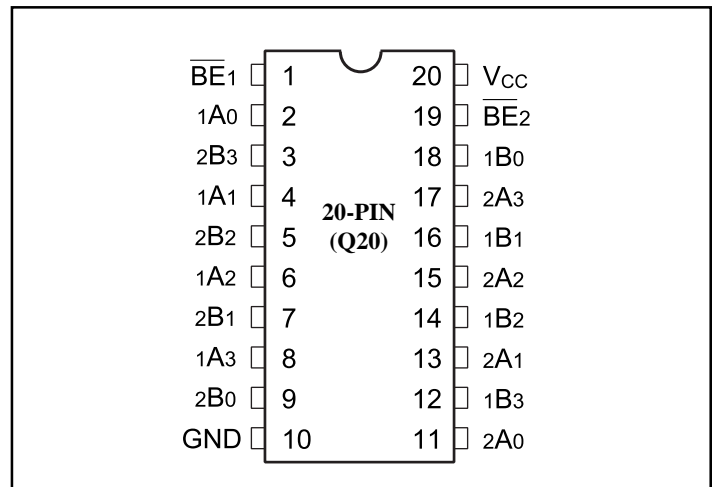

Product Pin Description

Pin Name	Description
\overline{BEn}	Bus Enable Input (Active LOW)
A0-7	Bus A
B0-7	Bus B
GND	Ground
VCC	Power

Truth Table⁽¹⁾

$\overline{BE1}$	$\overline{BE2}$	1A, 1B	2A, 2B
H	H	Disconnect	Disconnect
L	H	1A = 1B	Disconnect
H	L	Disconnect	2A = 2B
L	L	1A = 1B	2A = 2B

Note:

1. H = High Voltage Level
L = Low Voltage Level

Maximum Ratings

(Above which the useful life may be impaired. For user guidelines, not tested.)

Storage Temperature	-65°C to +150°C
Ambient Temperature with Power Applied	-40°C to +85°C
Supply Voltage to Ground Potential	-0.5V to +4.6V
DC Input Voltage	-0.5V to +4.6V
DC Output Current	120mA
Power Dissipation	0.5W

Note:

Stresses greater than those listed under MAXIMUM RATINGS may cause permanent damage to the device. This is a stress rating only and functional operation of the device at these or any other conditions above those indicated in the operational sections of this specification is not implied. Exposure to absolute maximum rating conditions for extended periods may affect reliability.

DC Electrical Characteristics (Over the Operating Range, $T_A = -40^\circ\text{C}$ to $+85^\circ\text{C}$, $V_{CC} = 3.3\text{V} \pm 10\%$)

Parameters	Description	Test Conditions ⁽¹⁾	Min.	Typ. ⁽²⁾	Max.	Units
V_{IH}	Input HIGH Voltage	Guaranteed Logic HIGH Level	2.0			V
V_{IL}	Input LOW Voltage	Guaranteed Logic LOW Level	-0.5		0.8	
I_{IH}	Input HIGH Current	$V_{CC} = \text{Max.}, V_{IN} = V_{CC}$			± 1	μA
I_{IL}	Input LOW Current	$V_{CC} = \text{Max.}, V_{IN} = \text{GND}$			± 1	
I_{OZH}	High Impedance Output Current	$0 \leq A, B \leq V_{CC}$			± 1	
V_{IK} V	Clamp Diode Voltage	$V_{CC} = \text{Min.}, I_{IN} = -18\text{mA}$			-0.73	-1.2
R_{ON}	Switch On Resistance ⁽⁴⁾	$V_{CC} = \text{Min.}, V_{IN} = 0.0\text{V}, I_{ON} = 48\text{mA}$ or 64mA $V_{CC} = \text{Min.}, V_{IN} = 2.4\text{V}, I_{ON} = 15\text{mA}$		5 8	7 15	Ω

Capacitance ($T_A = 25^\circ\text{C}$, $f = 1\text{MHz}$)

Parameters ⁽⁵⁾	Description	Test Conditions	Typ.	Units
C_{IN}	Input Capacitance	$V_{IN} = 0\text{V}$	3.5	pF
C_{OFF}	A/B Capacitance, Switch Off	$V_{IN} = 0\text{V}$	5.0	
C_{ON}	A/B Capacitance, Switch On	$V_{IN} = 0\text{V}$	10.0	

Notes:

1. For Max. or Min. conditions, use appropriate value specified under Electrical Characteristics for the applicable device type.
2. Typical values are at $V_{CC} = 3.3\text{V}$, $T_A = 25^\circ\text{C}$ ambient and maximum loading.
3. Not more than one output should be shorted at one time. Duration of the test should not exceed one second.
4. Measured by the voltage drop between A and B pin at indicated current through the switch. ON resistance is determined by the lower of the voltages on the two (A,B) pins.
5. This parameter is determined by device characterization but is not production tested.

Power Supply Characteristics

Parameters	Description	Test Conditions ⁽¹⁾		Min.	Typ. ⁽²⁾	Max.	Units
I _{CC}	Quiescent Power Supply Current	V _{CC} = Max.	V _{IN} = GND or V _{CC}		260	500	μA
ΔI _{CC}	Supply Current per Input HIGH	V _{CC} = Max.	V _{IN} = 3.0V ⁽³⁾			750	

Notes:

1. For Max. or Min. conditions, use appropriate value specified under Electrical Characteristics for the applicable device.
2. Typical values are at V_{CC} = 3.3V, +25°C ambient.
3. Per driven input (control input only); A and B pins do not contribute to ΔI_{CC}.
4. This current applies to the control inputs only and represent the current required to switch internal capacitance at the specified frequency. The A and B inputs generate no significant AC or DC currents as they transition. This parameter is not tested, but is guaranteed by design.

Switching Characteristics over Operating Range

Parameters	Description	Conditions ⁽¹⁾	PI3C3244		Units
			Com.		
			Min.	Max.	
t _{PLH} t _{PHL}	Propagation Delay ^(2,3) A _x to B _x	C _L = 50 pF, R _L = 500Ω		0.25	ns
t _{PZH} t _{PZL}	Bus Enable Time \overline{BE} to A _x or B _x	C _L = 50 pF, R _L = 500Ω,	1.5	6.5	
t _{PHZ} t _{PLZ}	Bus Disable Time \overline{BE} to A _x or B _x	R = 500Ω	1.5	5.5	

Notes:

1. See test circuit and waveforms.
2. This parameter is guaranteed but not tested on Propagation Delays.
3. The bus switch contributes no propagational delay other than the RC delay of the ON resistance of the switch and the load capacitance. The time constant for the switch alone is of the order of 0.25ns for 50pF load. Since this time constant is much smaller than the rise/fall times of typical driving signals, it adds very little propagational delay to the system. Propagational delay of the bus switch when used in a system is determined by the driving circuit on the driving side of the switch and its interaction with the load on the driven side.