

# 54ACT16474, 74ACT16474 18-BIT REGISTERED BUS TRANSCEIVERS WITH 3-STATE OUTPUTS

SCAS238A – MAY 1992 – REVISED APRIL 1996

- Members of the Texas Instruments *Widebus™* Family
- Inputs Are TTL-Voltage Compatible
- 3-State Outputs Drive Bus Lines Directly
- Flow-Through Architecture Optimizes PCB Layout
- Distributed  $V_{CC}$  and GND Pin Configurations Minimize High-Speed Switching Noise
- *EPIC™* (Enhanced-Performance Implanted CMOS) 1- $\mu$ m Process
- 500-mA Typical Latch-Up Immunity at 125°C
- Package Options Include Plastic 300-mil Shrink Small-Outline (DL) Packages Using 25-mil Center-to-Center Pin Spacings and 380-mil Fine-Pitch Ceramic Flat (WD) Packages Using 25-mil Center-to-Center Pin Spacings

## description

The 'ACT16474 are noninverting 18-bit registered bus transceivers composed of two 9-bit sections with separate control signals. For either 9-bit transceiver section, data flow in the A-to-B mode is controlled by output-enable ( $\overline{1OEAB}$  or  $\overline{2OEAB}$ ) and clock ( $\overline{1CLKAB}$  or  $\overline{2CLKAB}$ ) inputs. When  $\overline{1OEAB}$  or  $\overline{2OEAB}$  is low, the corresponding outputs are active (high or low) and take on either the current data on low-to-high transition of  $\overline{1CLKAB}$  or  $\overline{2CLKAB}$  or the previously stored data if  $\overline{1CLKAB}$  or  $\overline{2CLKAB}$  is low.

When  $\overline{1OEAB}$  or  $\overline{2OEAB}$  is high, the corresponding outputs are in the high-impedance state.  $\overline{1OEAB}$  or  $\overline{2OEAB}$  does not affect the operation on the internal registers. Previously stored data can be retained or new data can be entered while the outputs are in the high-impedance state.

Data flow from B to A is similar, but uses  $\overline{1OEBA}$  and/or  $\overline{2OEBA}$  and  $\overline{1CLKBA}$  and/or  $\overline{2CLKBA}$ .

The 74ACT16474 is packaged in TI's shrink small-outline package, which provides twice the I/O pin count and functionality of standard small-outline packages in the same printed-circuit-board area.

The 54ACT16474 is characterized for operation over the full military temperature range of -55°C to 125°C. The 74ACT16474 is characterized for operation from -40°C to 85°C.

54ACT16474 ... WD PACKAGE  
74ACT16474 ... DL PACKAGE  
(TOP VIEW)

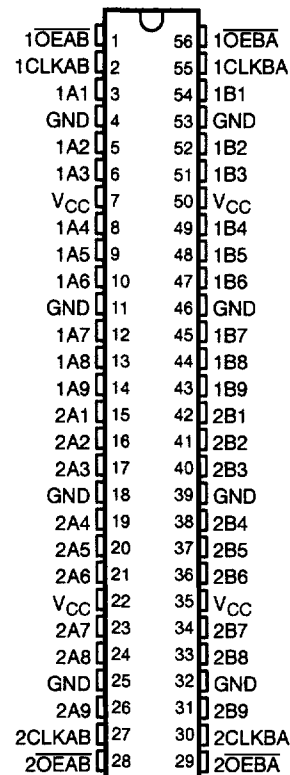

EPIC and Widebus are trademarks of Texas Instruments Incorporated.

UNLESS OTHERWISE NOTED this document contains PRODUCTION DATA information current as of publication date. Products conform to specifications per the terms of Texas Instruments standard warranty. Production processing does not necessarily include testing of all parameters.



POST OFFICE BOX 655303 • DALLAS, TEXAS 75265

Copyright © 1996, Texas Instruments Incorporated

# 54ACT16474, 74ACT16474 18-BIT REGISTERED BUS TRANSCEIVERS WITH 3-STATE OUTPUTS

SCAS238A - MAY 1992 - REVISED APRIL 1996

FUNCTION TABLE†

INPUTS			OUTPUT
CLKAB	OEAB	A	B
X	H	X	Z
L	L	X	B <sub>0</sub> ‡
↑	L	H	H
↑	L	L	L

† A-to-B data flow is shown; B-to-A flow is similar but uses CLKBA, and OEBA.

‡ Output level before the indicated steady-state input conditions were established

logic symbol§

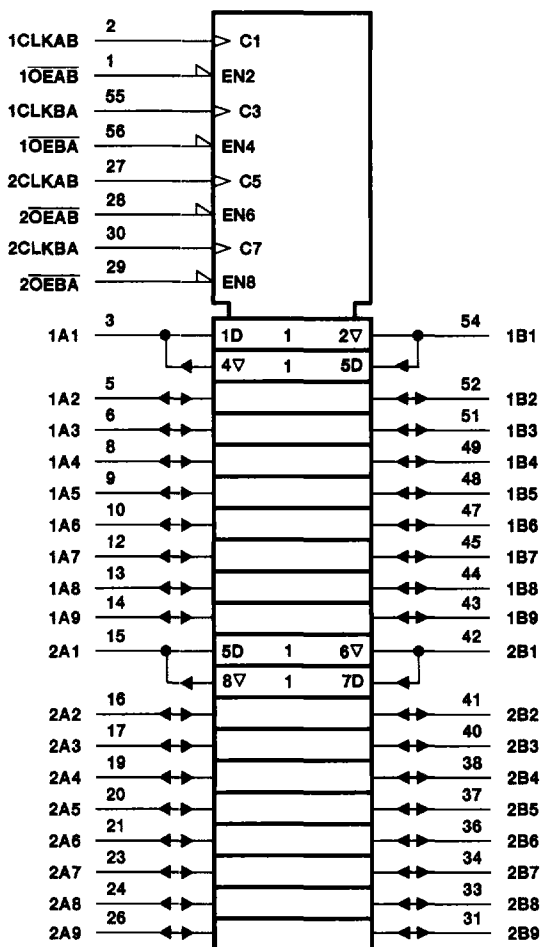

§ This symbol is in accordance with ANSI/IEEE Std 91-1984 and IEC Publication 617-12.



**54ACT16474, 74ACT16474**  
**18-BIT REGISTERED BUS TRANSCEIVERS**  
**WITH 3-STATE OUTPUTS**  
 SCAS238A - MAY 1992 - REVISED APRIL 1996

logic diagram (positive logic)

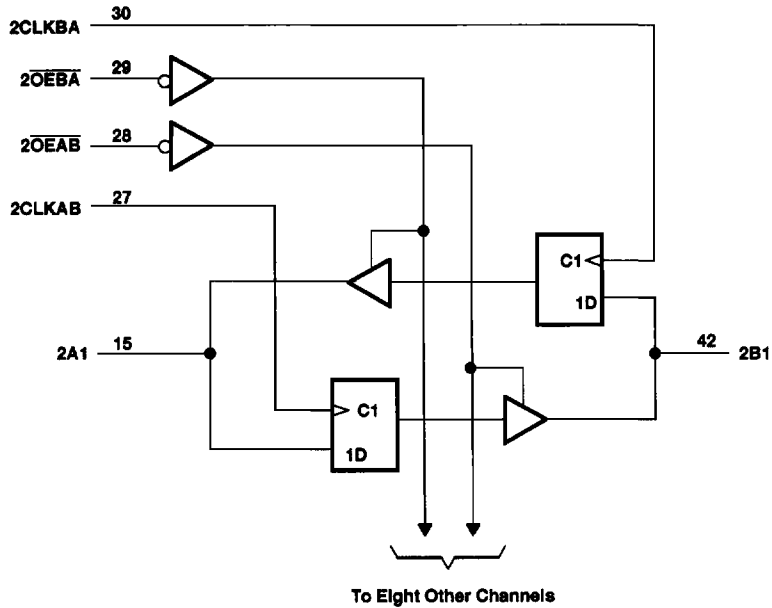
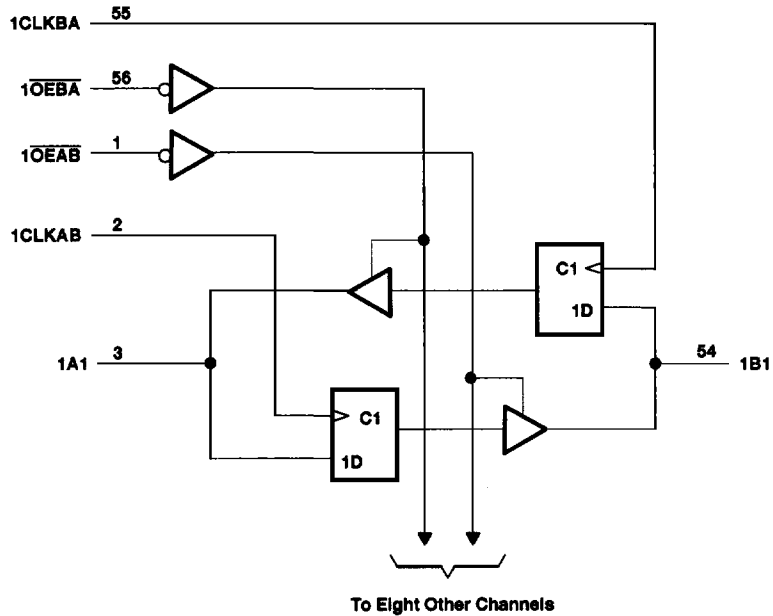

# 54ACT16474, 74ACT16474 18-BIT REGISTERED BUS TRANSCEIVERS WITH 3-STATE OUTPUTS

SCAS238A – MAY 1992 – REVISED APRIL 1998

## absolute maximum ratings over operating free-air temperature range (unless otherwise noted)†

Supply voltage range, $V_{CC}$ .....	-0.5 to 7 V
Input voltage range, $V_I$ (see Note 1) .....	-0.5 to $V_{CC} + 0.5$ V
Input voltage range, $V_O$ (see Note 1) .....	-0.5 to $V_{CC} + 0.5$ V
Input clamp current, $I_{IK}$ ( $V_I < 0$ or $V_I > V_{CC}$ ) .....	$\pm 20$ mA
Output clamp current, $I_{OK}$ ( $V_O < 0$ or $V_O > V_{CC}$ ) .....	$\pm 50$ mA
Continuous output current, $I_O$ ( $V_O = 0$ to $V_{CC}$ ) .....	$\pm 50$ mA
Continuous current through $V_{CC}$ or GND .....	$\pm 450$ mA
Maximum package power dissipation at $T_A = 55^\circ\text{C}$ (in still air) (see Note 2): DL package .....	1.4 W
Storage temperature range, $T_{stg}$ .....	$-65^\circ\text{C}$ to $150^\circ\text{C}$

† Stresses beyond those listed under "absolute maximum ratings" may cause permanent damage to the device. These are stress ratings only, and functional operation of the device at these or any other conditions beyond those indicated under "recommended operating conditions" is not implied. Exposure to absolute-maximum-rated conditions for extended periods may affect device reliability.

- NOTES: 1. The input and output voltage ratings may be exceeded if the input and output current ratings are observed.  
2. The maximum package power dissipation is calculated using a junction temperature of  $150^\circ\text{C}$  and a board trace length of 750 mils.

## recommended operating conditions (see Note 3)

	54ACT16474			74ACT16474			UNIT
	MIN	NOM	MAX	MIN	NOM	MAX	
$V_{CC}$ Supply voltage	4.5	5	5.5	4.5	5	5.5	V
$V_{IH}$ High-level input voltage	2			2			V
$V_{IL}$ Low-level input voltage			0.8			0.8	V
$V_I$ Input voltage	0		$V_{CC}$	0		$V_{CC}$	V
$V_O$ Output voltage	0		$V_{CC}$	0		$V_{CC}$	V
$I_{OH}$ High-level output current			-24			-24	mA
$I_{OL}$ Low-level output current			24			24	mA
$\Delta t/\Delta v$ Input transition rise or fall rate			10			10	ns/V
$T_A$ Operating free-air temperature	-55		125	-40		85	$^\circ\text{C}$

NOTE 3: Unused pins (input or I/O) must be held high or low to prevent them from floating.

**54ACT16474, 74ACT16474**  
**18-BIT REGISTERED BUS TRANSCEIVERS**  
**WITH 3-STATE OUTPUTS**

SCAS238A – MAY 1992 – REVISED APRIL 1996

**electrical characteristics over recommended operating free-air temperature range (unless otherwise noted)**

PARAMETER	TEST CONDITIONS	V <sub>CC</sub>	T <sub>A</sub> = 25°C			54ACT16474		74ACT16474		UNIT
			MIN	TYP	MAX	MIN	MAX	MIN	MAX	
V <sub>OH</sub>	I <sub>OH</sub> = -50 μA	4.5 V	4.4		4.4	4.4			V	
		5.5 V	5.4		5.4	5.4				
	I <sub>OH</sub> = -24 mA	4.5 V	3.94		3.8	3.8				
		5.5 V	4.94		4.8	4.8				
	I <sub>OH</sub> = -75 mA†	5.5 V			3.85	3.85				
V <sub>OL</sub>	I <sub>OL</sub> = 50 μA	4.5 V		0.1	0.1	0.1			V	
		5.5 V		0.1			0.1			
	I <sub>OL</sub> = 24 mA	4.5 V		0.36	0.44	0.44				
		5.5 V		0.36	0.44	0.44				
	I <sub>OL</sub> = 75 mA†	5.5 V			1.65	1.65				
I <sub>I</sub>	Control inputs	V <sub>I</sub> = V <sub>CC</sub> or GND	5.5 V		±0.1	±1	±1	±1	μA	
I <sub>OZ</sub> ‡	A or B ports	V <sub>O</sub> = V <sub>CC</sub> or GND	5.5 V		±0.5	±5	±5	±5	μA	
I <sub>CC</sub>		V <sub>I</sub> = V <sub>CC</sub> or GND, I <sub>O</sub> = 0	5.5 V		8	80	80	80	μA	
ΔI <sub>CC</sub> §		One input at 3.4 V, Other inputs at V <sub>CC</sub> or GND	5.5 V		0.9	1	1	1	mA	
C <sub>i</sub>	Control inputs	V <sub>I</sub> = V <sub>CC</sub> or GND	5 V		3				pF	
C <sub>io</sub>	A or B ports	V <sub>O</sub> = V <sub>CC</sub> or GND	5 V		11.5				pF	

† Not more than one output should be tested at a time, and the duration of the test should not exceed 10 ms.

‡ For I/O ports, the parameter I<sub>OZ</sub> includes the input leakage current.

§ This is the increase in supply current for each input that is at one of the specified TTL voltage levels rather than 0 V or V<sub>CC</sub>.

**timing requirements over recommended operating free-air temperature range, V<sub>CC</sub> = 5 V ± 0.5 V (unless otherwise noted) (see Figure 1)**

			T <sub>A</sub> = 25°C			54ACT16474		74ACT16474		UNIT
			MIN	TYP	MAX	MIN	MAX	MIN	MAX	
f <sub>clock</sub>	Clock frequency		0	75		0	75	0	75	MHz
t <sub>w</sub>	Pulse duration	CLK high	4		4	4		4		ns
		CLK low	6.6		6.6	6.6		6.6		ns
t <sub>su</sub>	Setup time	Data before CLK↑	5.5		5.5	5.5		5.5		ns
t <sub>h</sub>	Hold time	Data after CLK↑	1		1	1		1		ns

**switching characteristics over recommended operating free-air temperature range, V<sub>CC</sub> = 5 V ± 0.5 V (unless otherwise noted) (see Figure 1)**

PARAMETER	FROM (INPUT)	TO (OUTPUT)	T <sub>A</sub> = 25°C			54ACT16474		74ACT16474		UNIT
			MIN	TYP	MAX	MIN	MAX	MIN	MAX	
f <sub>max</sub>			75		75	75		75		MHz
t <sub>PLH</sub>	CLK	A or B	4	8	10.2	4	5	4	11.5	ns
t <sub>PHL</sub>			4.2	8	10.2	4.2	11.4	4.2	11.4	
t <sub>PZH</sub>	OE	A or B	3	7.8	10.3	3	11.7	3	11.7	ns
t <sub>PZL</sub>			3.7	9.2	11.6	3.7	13.1	3.7	13.1	
t <sub>PHZ</sub>	OE	A or B	4.8	7.1	8.8	4.8	9.5	4.8	9.5	ns
t <sub>PLZ</sub>			4.4	6.6	8.4	4.4	9	4.4	9	

PRODUCT PREVIEW information concerns products in the formative or design phase of development. Characteristic data and other specifications are design goals. Texas Instruments reserves the right to change or discontinue these products without notice.



**54ACT16474, 74ACT16474**  
**18-BIT REGISTERED BUS TRANSCEIVERS**  
**WITH 3-STATE OUTPUTS**

SCAS238A - MAY 1992 - REVISED APRIL 1996

operating characteristics,  $V_{CC} = 5\text{ V}$ ,  $T_A = 25^\circ\text{C}$

PARAMETER		TEST CONDITIONS	TYP	UNIT
$C_{pd}$	Power dissipation capacitance per transceiver	$C_L = 50\text{ pF}$ , $f = 1\text{ MHz}$	61	pF
			37	

**PARAMETER MEASUREMENT INFORMATION**

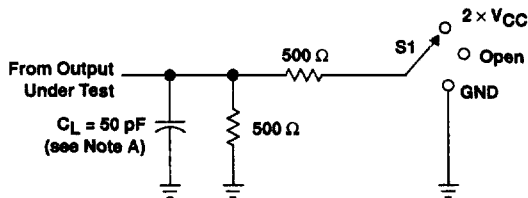

LOAD CIRCUIT

TEST	S1
$t_{PLH}/t_{PHL}$	Open
$t_{PLZ}/t_{PZL}$	$2 \times V_{CC}$
$t_{PHZ}/t_{PZH}$	GND

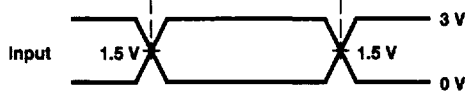

VOLTAGE WAVEFORMS

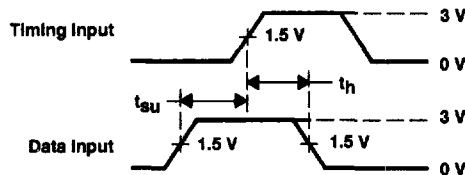

VOLTAGE WAVEFORMS

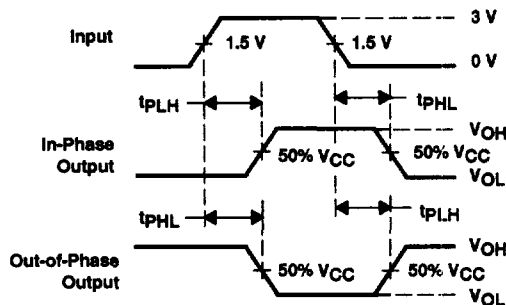

VOLTAGE WAVEFORMS

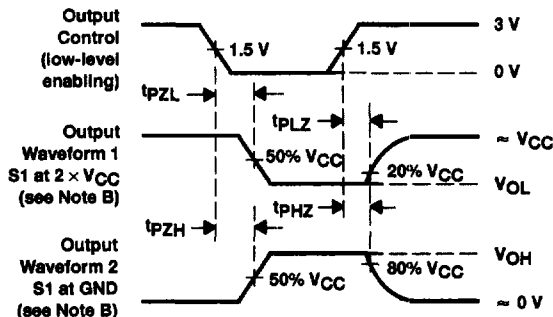

VOLTAGE WAVEFORMS

- NOTES: A.  $C_L$  includes probe and jig capacitance.  
 B. Waveform 1 is for an output with internal conditions such that the output is low except when disabled by the output control. Waveform 2 is for an output with internal conditions such that the output is high except when disabled by the output control.  
 C. All input pulses are supplied by generators having the following characteristics:  $PRR \leq 1\text{ MHz}$ ,  $Z_O = 50\ \Omega$ ,  $t_r = 3\text{ ns}$ ,  $t_f = 3\text{ ns}$ .  
 D. The outputs are measured one at a time with one input transition per measurement.

**Figure 1. Load Circuit and Voltage Waveforms**