

DATA SHEET

74AC16244/74ACT16244 16-bit buffer/line driver (3-State)

Product specification

1997 Jul 15

16-bit buffer/line driver (3-State)

74AC16244
74ACT16244

FEATURES

- 74ACT16244 has TTL-compatible inputs
- 74AC16244 has CMOS-compatible inputs
- 3-State outputs source/sink 24mA
- 3-State outputs drive bus lines or buffer memory address registers
- Distributed power and ground pins for minimum noise and ground bounce
- Meets or exceeds JEDEC standard for 74AC(T)XX family

DESCRIPTION

The 74AC/T16244 is a high-performance, low-power, low-voltage, Si-gate CMOS device, superior to most advanced CMOS compatible TTL families.

The '16244' is a 16-bit non-inverting buffer/line driver with 3-State outputs. The device can be used as four 4-bit buffers, two 8-bit buffers or one 16-bit buffer. The 3-State outputs are controlled by the output enable inputs 1OE and 2OE. A HIGH on nOE causes the outputs to assume a high impedance OFF-state.

The 74AC/T16244 is identical to the 74AC/T16240 but has non-inverting outputs.

PIN CONFIGURATION

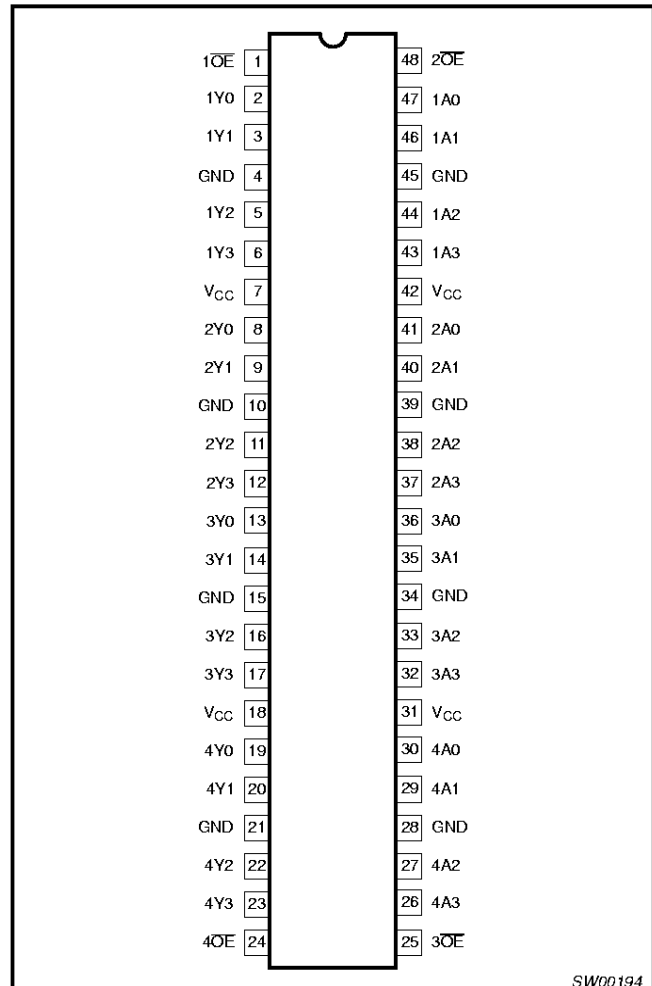

SW00194

QUICK REFERENCE DATA

GND = 0 V; $T_{amb} = 25^{\circ}\text{C}$; $t_r = t_f \leq 2.5$ ns

SYMBOL	PARAMETER	CONDITIONS	TYPICAL			UNIT
			AC		ACT	
			$V_{CC} = 3.3\text{V}$	$V_{CC} = 5.0\text{V}$	$V_{CC} = 5.0\text{V}$	
t_{PHL}/t_{PLH}	Propagation delay nAx to nYx; nYx to nAx	$C_L = 50\text{pF}$	3.3	2.3	3.4	ns
C_I	Input capacitance		4.5			pF
C_{PD}	Power dissipation capacitance	$V_I = \text{GND to } V_{CC}^1$ outputs enabled outputs disabled	32 6		38 6	pF

NOTE:

1. C_{PD} is used to determine the dynamic power dissipation (P_D in μW): $P_D = C_{PD} \times V_{CC}^2 \times f_i + \sum (C_L \times V_{CC}^2 \times f_o)$ where:
 f_i = input frequency in MHz; C_L = output load capacity in pF; f_o = output frequency in MHz; V_{CC} = supply voltage in V;
 $\sum (C_L \times V_{CC}^2 \times f_o)$ = sum of the outputs.

ORDERING INFORMATION

PACKAGES	TEMPERATURE RANGE	OUTSIDE NORTH AMERICA	NORTH AMERICA	DWG NUMBER
48-Pin Plastic SSOP Type III	-40°C to $+85^{\circ}\text{C}$	74AC16244 DL 74ACT16244 DL	7AC16244 DL 7AT16244 DL	SOT370-1
48-Pin Plastic TSSOP Type II	-40°C to $+85^{\circ}\text{C}$	74AC16244 DGG 74ACT16244 DGG	7AC16244 DGG 7AT16244 DGG	SOT362-1

16-bit buffer/line driver (3-State)

74AC16244
74ACT16244

PIN DESCRIPTION

PIN NUMBER	SYMBOL	NAME AND FUNCTION
47, 46, 44, 43, 41, 40, 38, 37, 36, 35, 33, 32, 30, 29, 27, 26	1A0 to 1A3, 2A0 to 2A3, 3A0 to 3A3, 4A0 to 4A3	Data inputs
2, 3, 5, 6, 8, 9, 11, 12, 13, 14, 16, 17, 19, 20, 22, 23	1Y0 to 1Y3, 2Y0 to 2Y3, 3Y0 to 3Y3, 4Y0 to 4Y3	Data outputs
1, 48, 25, 24	1OE, 2OE, 3OE, 4OE	Output enables
4, 10, 15, 21, 28, 34, 39, 45	GND	Ground (0V)
7, 18, 31, 42	V _{CC}	Positive supply voltage

LOGIC SYMBOL

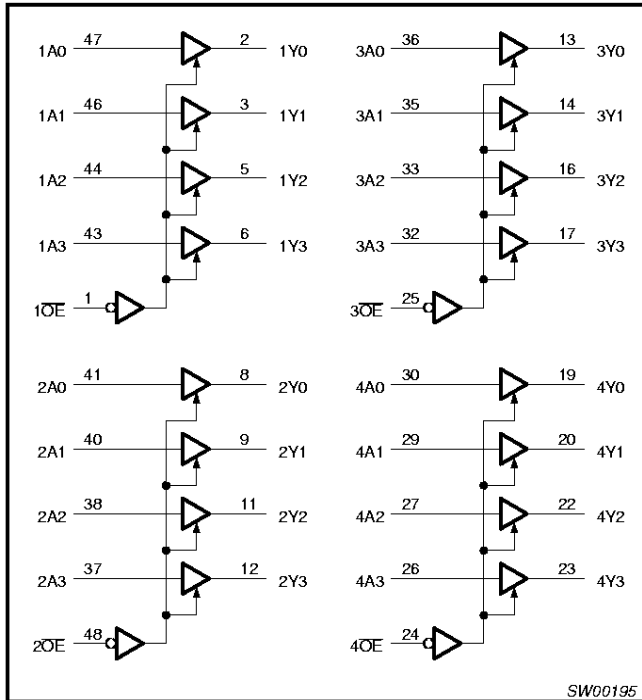

FUNCTION TABLE

INPUTS		OUTPUT
nOE	nAn	nYn
L	L	L
L	H	H
H	X	Z

H = HIGH voltage level
L = LOW voltage level
X = don't care
Z = high impedance OFF-state

LOGIC SYMBOL (IEEE/IEC)

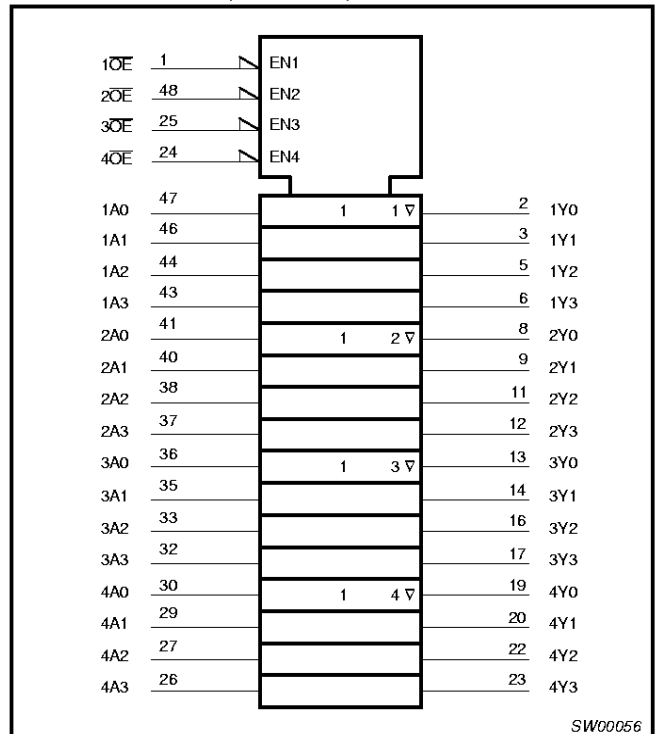

16-bit buffer/line driver (3-State)

74AC16244
74ACT16244

RECOMMENDED OPERATING CONDITIONS

SYMBOL	PARAMETER	LIMITS		UNIT
		MIN	MAX	
V_{CC}	DC supply voltage for 'AC	2.0	6.0	V
V_{CC}	DC supply voltage for 'ACT	4.5	5.5	V
V_{IN}	DC input voltage range	0	V_{CC}	V
V_O	DC output voltage range	0	V_{CC}	V
T_{amb}	Operating free-air temperature range	-40	+85	°C
$\Delta V/\Delta t$	Minimum input edge rate — AC devices V_{IN} from 30% to 70% of V_{CC} V_{CC} @ 3.3V, 4.5V, 5.5V	125		mV/ns
	— ACT devices V_{IN} from 0.8V to 2.0V V_{CC} @ 4.5V, 5.5V	125		

ABSOLUTE MAXIMUM RATINGS¹

in accordance with the Absolute Maximum Rating System (IEC134)

Voltages are referenced to GND (ground = 0V)

SYMBOL	PARAMETER	CONDITIONS	RATING	UNIT
V_{CC}	DC supply voltage		-0.5 to +7.0	V
I_{IK}	DC input diode current	$V_{IN} = -0.5V$	-20	mA
		$V_{IN} = V_{CC} + 0.5V$	+20	
V_{IN}	DC input voltage		-0.5 to $V_{CC} + 0.5$	V
I_{OK}	DC output diode current	$V_O = -0.5V$	-20	mA
		$V_O = V_{CC} + 0.5V$	+20	
V_O	DC output voltage		-0.5 to $V_{CC} + 0.5$	V
I_O	DC output source or sink current		± 50	mA
I_{CC}, I_{GND}	DC V_{CC} or GND current per output		± 50	mA
I_{CC}, I_{GND}	DC V_{CC} or GND current		± 200	mA
T_{stg}	Storage temperature range		-65 to 150	°C
P_{TOT}	Power dissipation per package — plastic mini-pack (SO) — plastic shrink mini-pack (SSOP and TSSOP)	above +70°C derate linearly with 8 mW/K	500	mW
		above +60°C derate linearly with 5.5 mW/K	500	

NOTES:

- Stresses beyond those listed may cause permanent damage to the device. These are stress ratings only and functional operation of the device at these or any other conditions beyond those indicated under "recommended operating conditions" is not implied. Exposure to absolute-maximum-rated conditions for extended periods may affect device reliability.

16-bit buffer/line driver (3-State)

74AC16244
74ACT16244**DC ELECTRICAL CHARACTERISTICS FOR 74AC16244**

Over recommended operating conditions voltages are referenced to GND (ground = 0V)

SYMBOL	PARAMETER	TEST CONDITIONS	V _{CC} (V)	LIMITS			UNIT
				Temp = -40°C to +85°C			
				MIN	TYP ¹	MAX	
V _{IH}	HIGH level Input voltage	V _{OUT} = 0.1V or (V _{CC} - 0.1V)	3.0	2.1	1.5		V
			4.5	3.15	2.25		
			5.5	3.85	2.75		
V _{IL}	LOW level Input voltage	V _{OUT} = 0.1V or (V _{CC} - 0.1V)	3.0		1.5	0.9	V
			4.5		2.25	1.35	
			5.5		2.75	1.65	
V _{OH}	HIGH level output voltage	I _{OUT} = -50 μA	3.0	2.9	2.99		V
			4.5	4.4	4.49		
			5.5	5.4	5.49		
		V _{IN} = V _{IL} or V _{IH} , I _{OH} = -12mA ¹	3.0	2.46			V
		V _{IN} = V _{IL} or V _{IH} , I _{OH} = -24mA ¹	4.5	3.76			
V _{IN} = V _{IL} or V _{IH} , I _{OH} = -24mA ¹	5.5	4.76					
V _{OL}	LOW level output voltage	I _{OUT} = 50 μA	3.0		0.01	0.1	V
			4.5		0.01	0.1	
			5.5		0.01	0.1	
		V _{IN} = V _{IL} or V _{IH} , I _{OL} = 12mA ¹	3.0			0.44	V
		V _{IN} = V _{IL} or V _{IH} , I _{OL} = 24mA ¹	4.5			0.44	
		V _{IN} = V _{IL} or V _{IH} , I _{OL} = 24mA ¹	5.5			0.44	
I _{IN}	Input leakage current	V _{IN} = V _{CC} , GND	5.5			± 1.0	μA
I _{OZ}	3-State output OFF-state current	V _{IN} (OE) = V _{IL} , V _{IH} V _{IN} = V _{CC} , GND V _{OUT} = V _{CC} , GND	5.5			± 2.5	μA
I _{OLD} ²	Dynamic output current ²	V _{OLD} = 1.65V max	5.5	75			mA
I _{OHD} ²	Dynamic output current ²	V _{OHD} = 3.85V min	5.5			-75	mA
I _{CC}	Quiescent supply current	V _{IN} = V _{CC} or GND	5.5			80	μA

NOTES:

- All outputs loaded
- Maximum test duration 2.0 ms; one output loaded at a time

16-bit buffer/line driver (3-State)

74AC16244
74ACT16244**DC ELECTRICAL CHARACTERISTICS FOR 74ACT16244**

Over recommended operating conditions voltages are referenced to GND (ground = 0V)

SYMBOL	PARAMETER	TEST CONDITIONS	V _{CC} (V)	LIMITS			UNIT
				Temp = -40°C to +85°C			
				MIN	TYP ¹	MAX	
V _{IH}	HIGH level Input voltage	V _{OUT} = 0.1V or (V _{CC} - 0.1V)	4.5	2.0	1.5	V	
			5.5	2.0	1.5		
V _{IL}	LOW level Input voltage	V _{OUT} = 0.1V or (V _{CC} - 0.1V)	4.5		1.5	0.8	V
			5.5		1.5	0.8	
V _{OH}	HIGH level output voltage	I _{OUT} = -50 μA	4.5	4.4	4.49	V	
			5.5	5.4	5.49		
		V _{IN} = V _{IL} or V _{IH} , I _{OH} = -24mA ¹	4.5	3.76	3.86	V	
			5.5	4.76	4.86		
V _{OL}	LOW level output voltage	I _{OUT} = 50 μA	4.5		0.01	0.1	V
			5.5		0.01	0.1	
		V _{IN} = V _{IL} or V _{IH} , I _{OL} = 24mA ¹	4.5			0.44	V
			5.5			0.44	
I _{IN}	Input leakage current	V _{IN} = V _{CC} , GND	5.5			± 1.0	μA
I _{OZ}	3-State output OFF-state current	V _{IN} (OE) = V _{IL} , V _{IH} V _{IN} = V _{CC} , GND V _{OUT} = V _{CC} , GND	5.5			± 2.5	μA
ΔI _{CC}	Additional quiescent supply current per input pin	V _{IN} = V _{CC} - 2.1V Other inputs at V _{CC} or GND; I _{OUT} = 0	5.5			1.0	mA
I _{OLD} ²	Dynamic output current	V _{OLD} = 1.65V max	5.5	75			mA
I _{OHD} ²	Dynamic output current	V _{OHD} = 3.85V min	5.5			-75	mA
I _{CC}	Quiescent supply current	V _{IN} = V _{CC} or GND	5.5			80	μA

NOTES:

1. All outputs loaded
2. Maximum test duration 2.0ms, one output loaded at a time

16-bit buffer/line driver (3-State)

74AC16244
74ACT16244**AC CHARACTERISTICS FOR 74AC16244**GND = 0V; $t_r = t_f = 2.5\text{ns}$; $C_L = 50\text{pF}$; $R_L = 500\Omega$; .

SYMBOL	PARAMETER	V_{CC}^1 (V)	LIMITS					UNIT	WAVEFORM
			$T_{amb} = +25^\circ\text{C}$			$T_{amb} = -40^\circ\text{C to } +85^\circ\text{C}$			
			MIN	TYP	MAX	MIN	MAX		
t_{PLH}	Propagation delay nAx to nYx	3.3 5.0	2.0 1.5	3.4 2.3	8 6	1.5 1.0	9 7	ns	1, 3
t_{PHL}	Propagation delay nAx to nYx	3.3 5.0	2.0 1.5	3.2 2.3	8 6	1.5 1.0	9 7	ns	1, 3
t_{pZH}	3-State output enable time to HIGH level	3.3 5.0	2.0 1.5	4.6 3.1	9.5 6	1.5 1.0	11 7	ns	2, 3
t_{pZL}	3-State output enable time to LOW level	3.3 5.0	2.0 1.5	4.5 3.1	9.5 6	1.5 1.0	11 7	ns	2, 3
t_{pHZ}	3-State output disable time from HIGH level	3.3 5.0	2.0 1.5	3.5 2.4	9 5.5	1.5 1.0	10 6.5	ns	2, 3
t_{pLZ}	3-State output disable time from LOW level	3.3 5.0	2.0 1.5	4.2 2.9	9 5.5	1.5 1.0	10 6.5	ns	2, 3

NOTE:

- Voltage range 3.3V is $V_{CC} = 3.3\text{V} \pm 0.3\text{V}$
Voltage range 5.0V is $V_{CC} = 5.0\text{V} \pm 0.5\text{V}$

AC CHARACTERISTICS FOR 74ACT16244GND = 0V; $t_r = t_f = 2.5\text{ns}$; $C_L = 50\text{pF}$; $R_L = 500\Omega$; .

SYMBOL	PARAMETER	V_{CC}^1 (V)	LIMITS					UNIT	WAVEFORM
			$T_{amb} = +25^\circ\text{C}$			$T_{amb} = -40^\circ\text{C to } +85^\circ\text{C}$			
			MIN	TYP	MAX	MIN	MAX		
t_{PLH}	Propagation delay nAx to nYx	5.0	1.5	3.6	8	1.0	9	ns	1, 3
t_{PHL}	Propagation delay nAx to nYx	5.0	1.5	3.2	8	1.0	9	ns	1, 3
t_{pZH}	3-State output enable time to HIGH level	5.0	1.5	4.0	8	1.0	9	ns	2, 3
t_{pZL}	3-State output enable time to LOW level	5.0	1.5	4.0	8	1.0	9	ns	2, 3
t_{pHZ}	3-State output disable time from HIGH level	5.0	1.5	3.7	7.5	1.0	8.5	ns	2, 3
t_{pLZ}	3-State output disable time from LOW level	5.0	1.5	4.1	7.5	1.0	8.5	ns	2, 3

NOTE:

- Voltage range 5.0V is $V_{CC} = 5.0\text{V} \pm 0.5\text{V}$

16-bit buffer/line driver (3-State)

74AC16244
74ACT16244

AC WAVEFORMS

$V_m = 50\% V_{CC}$ for 'AC' devices; 1.5V for 'ACT' devices
 $V_m = 50\% V_{CC}$ for 'AC/ACT' devices

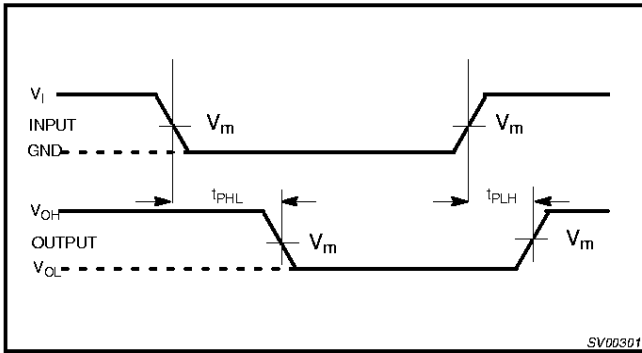

Waveform 1. Input to output propagation delay

V_{OL} and V_{OH} are the typical output voltage drops that occur with the output load.

$V_X = V_{OL} + 0.3V$
 $V_Y = V_{OH} - 0.3V$

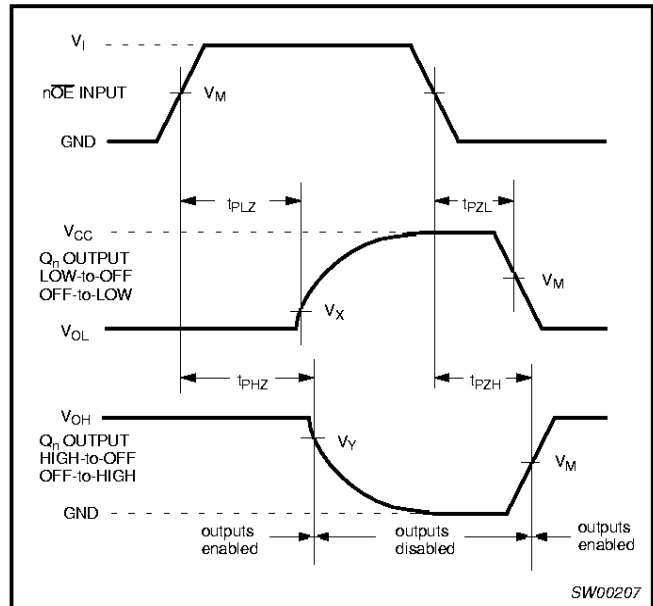

Waveform 2. 3-State output enable and disable times

TEST CIRCUIT

Test Circuit for 3-State Outputs

SWITCH POSITION		FAMILY	V_{IN} Input Requirements	V_m Input	V_m Output
TEST	SWITCH				
t_{PLH}/t_{PHL}	Open	AC	GND to V_{CC}	50% V_{CC}	50% V_{CC}
t_{PLZ}/t_{PZL}	$2 \times V_{CC}$				
t_{PHZ}/t_{PZH}	GND	ACT	GND to 3.0V	1.5V	50% V_{CC}

DEFINITIONS

R_L = Load resistor; see AC CHARACTERISTICS for value.
 C_L = Load capacitance, see AC characteristics
 R_T = Termination resistance should be equal to Z_{OUT} of pulse generators.

Waveform 3. Load circuitry for switching times.

16-bit buffer/line driver (3-State)

74AC16244
74ACT16244

SSOP48: plastic shrink small outline package; 48 leads; body width 7.5 mm

SOT370-1

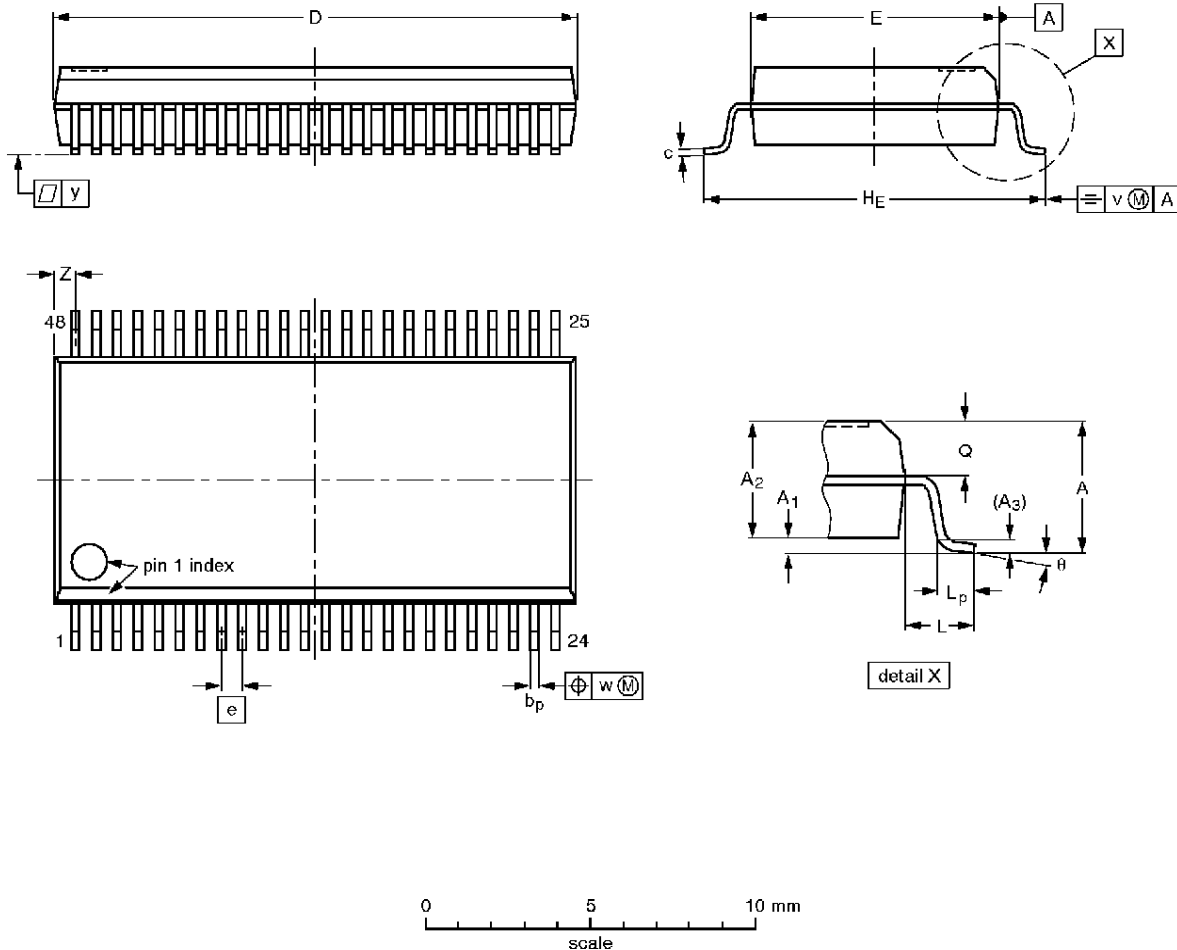

DIMENSIONS (mm are the original dimensions)

UNIT	A max.	A ₁	A ₂	A ₃	b _p	c	D ⁽¹⁾	E ⁽¹⁾	e	H _E	L	L _p	Q	v	w	y	Z ⁽¹⁾	θ
mm	2.8	0.4 0.2	2.35 2.20	0.25	0.3 0.2	0.22 0.13	16.00 15.75	7.6 7.4	0.635	10.4 10.1	1.4	1.0 0.6	1.2 1.0	0.25	0.18	0.1	0.85 0.40	8° 0°

Note

1. Plastic or metal protrusions of 0.25 mm maximum per side are not included.

OUTLINE VERSION	REFERENCES				EUROPEAN PROJECTION	ISSUE DATE
	IEC	JEDEC	EIAJ			
SOT370-1		MO-118AA				93-11-02 95-02-04

16-bit buffer/line driver (3-State)

74AC16244
74ACT16244

TSSOP48: plastic thin shrink small outline package; 48 leads; body width 6.1mm

SOT362-1

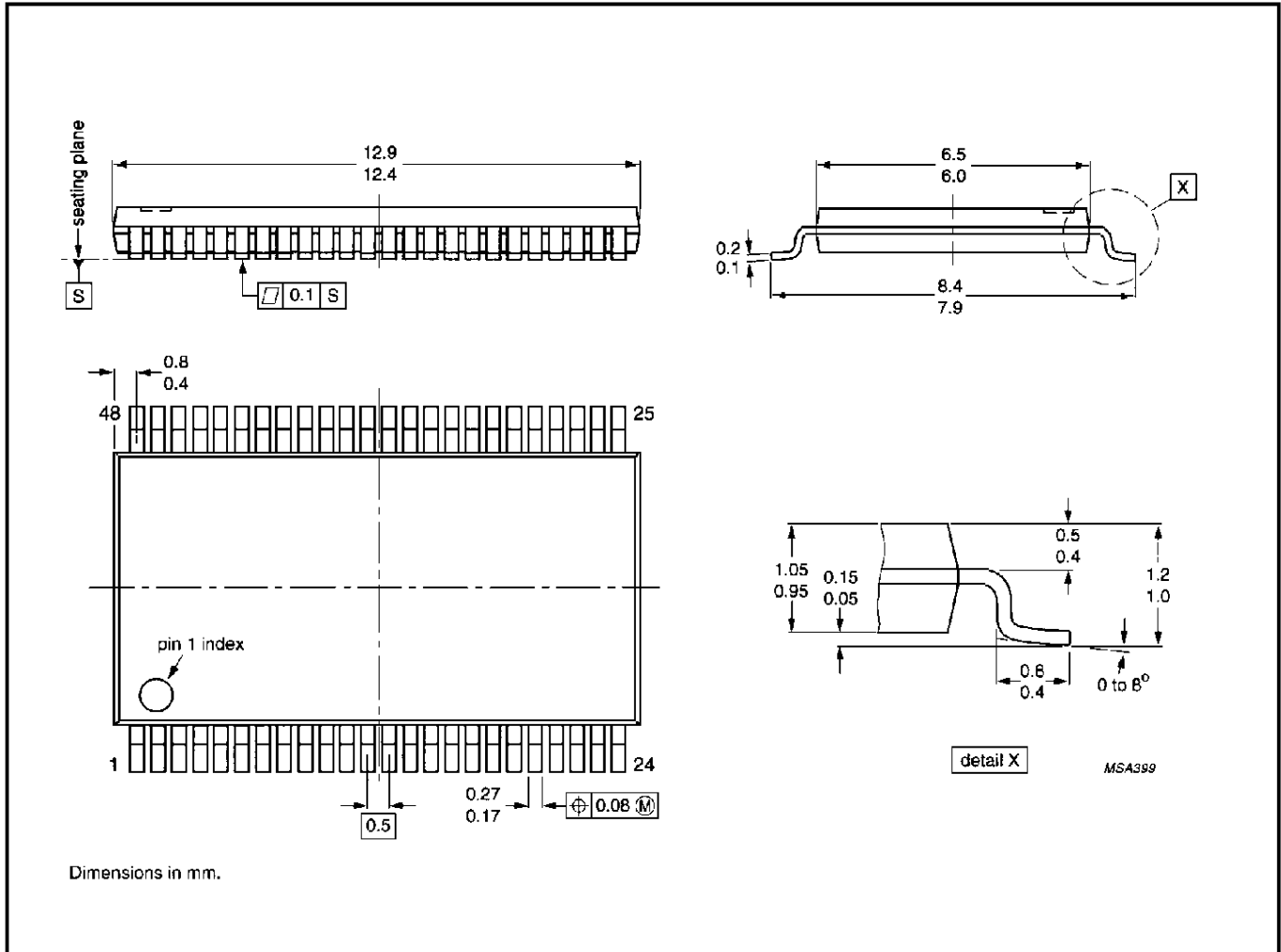

16-bit buffer/line driver (3-State)

74AC16244
74ACT16244

NOTES

16-bit buffer/line driver (3-State)

74AC16244
74ACT16244

DEFINITIONS

Data Sheet Identification	Product Status	Definition
<i>Objective Specification</i>	Formative or in Design	This data sheet contains the design target or goal specifications for product development. Specifications may change in any manner without notice.
<i>Preliminary Specification</i>	Preproduction Product	This data sheet contains preliminary data, and supplementary data will be published at a later date. Philips Semiconductors reserves the right to make changes at any time without notice in order to improve design and supply the best possible product.
<i>Product Specification</i>	Full Production	This data sheet contains Final Specifications. Philips Semiconductors reserves the right to make changes at any time without notice, in order to improve design and supply the best possible product.

Philips Semiconductors and Philips Electronics North America Corporation reserve the right to make changes, without notice, in the products, including circuits, standard cells, and/or software, described or contained herein in order to improve design and/or performance. Philips Semiconductors assumes no responsibility or liability for the use of any of these products, conveys no license or title under any patent, copyright, or mask work right to these products, and makes no representations or warranties that these products are free from patent, copyright, or mask work right infringement, unless otherwise specified. Applications that are described herein for any of these products are for illustrative purposes only. Philips Semiconductors makes no representation or warranty that such applications will be suitable for the specified use without further testing or modification.

LIFE SUPPORT APPLICATIONS

Philips Semiconductors and Philips Electronics North America Corporation Products are not designed for use in life support appliances, devices, or systems where malfunction of a Philips Semiconductors and Philips Electronics North America Corporation Product can reasonably be expected to result in a personal injury. Philips Semiconductors and Philips Electronics North America Corporation customers using or selling Philips Semiconductors and Philips Electronics North America Corporation Products for use in such applications do so at their own risk and agree to fully indemnify Philips Semiconductors and Philips Electronics North America Corporation for any damages resulting from such improper use or sale.

Philips Semiconductors
811 East Arques Avenue
P.O. Box 3409
Sunnyvale, California 94088-3409
Telephone 800-234-7381

Philips Semiconductors and Philips Electronics North America Corporation register eligible circuits under the Semiconductor Chip Protection Act.
 © Copyright Philips Electronics North America Corporation 1997
 All rights reserved. Printed in U.S.A.