

High-Speed 3.3V CMOS 8-Bit Buffer/Line Driver with Bus Hold

FEATURES/BENEFITS

- 5V tolerant inputs and outputs
- Bus Hold feature holds last active state during 3-state operation
- 10 μ A I_{CCQ} quiescent power supply current
- Hot insertable
- 2.0V-3.6V V_{CC} supply operation
- ± 24 mA balanced output drive
- Power down high impedance inputs and outputs
- Meets or exceeds JEDEC 36 specifications
- C speed performance: 4.1ns
- Input hysteresis for noise immunity
- Operating temperature range:
 -40°C to +85°C
- Latch-up performance exceeds 500mA
- ESD performance:
 Human body model > 2000V
 Machine model > 200V
- Packages available:
 20-pin QSOP
 20-pin SOIC

DESCRIPTION

The LCXH244 is an 8-bit buffers/line drivers with three-state outputs that is ideal for driving high capacitance loads such as memory address and data buses. The 3.3V LCXPlus family features low power, low switching noise, and fast switching speeds for low power portable applications as well as high-end, advanced workstation applications. 5V tolerant inputs and outputs allow these LCXPlus products to be used in mixed 5V and 3.3V applications. Active Bus Hold feature on LCXH244 retains the last valid logic state at unused or floating Data inputs, thus eliminating the need for external pull-up resistors. To accommodate hot-plug or live insertion applications, these products are designed not to load an active bus when V_{CC} is removed.

Figure 1. Functional Block Diagram

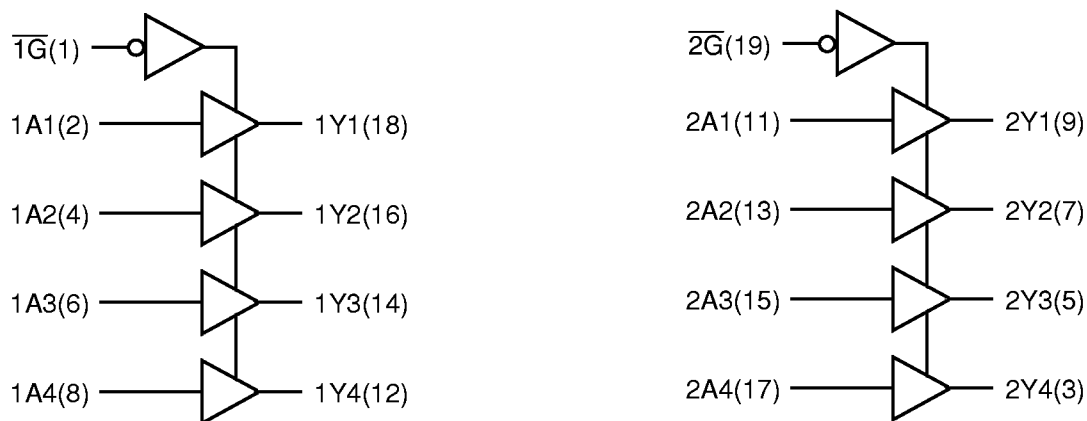

Figure 2. Pin Configurations
(All Pins Top View)

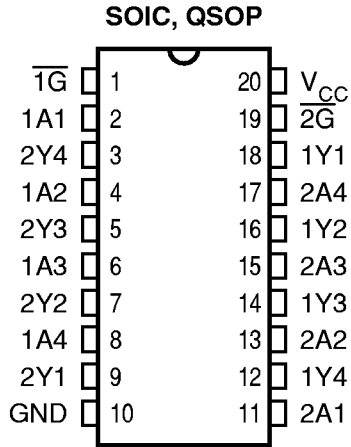

Table 1. Pin Description

Name	I/O	Description
xA1-xA4	I	Data Inputs
xY1-xY4	O	Three-State Data Outputs
$\overline{1G}$	I	Three-State Output Enable
$\overline{2G}$	I	Three-State Output Enable

Table 2. Function Table

$\overline{1G}/\overline{2G}$	Input A	Output Y
H	X	Z
L	L	L
L	H	H

Table 3. Capacitance

Symbol	Pins	Typ	Unit	Conditions
C_{IN}	Input Capacitance	7.0	pF	$V_{IN} = 0V, V_{OUT} = 0V, f = 1MHz$
$C_{I/O}$	I/O Capacitance	8.0	pF	$V_{IN} = 0V, V_{OUT} = 0V, f = 1MHz$
C_{PD}	Power Dissipation Capacitance	20	pF	$V_{CC} = 3.3V, V_{IN} = 0V$ or V_{CC} $f = 10MHz$

Note: Capacitance is characterized but not production tested.

Table 4. Absolute Maximum Ratings

Supply Voltage to Ground	-0.5V to 7.0V
DC Output Voltage V_{OUT}	
Outputs HIGH-Z	-0.5V to 7.0V
Outputs Active	-0.5V to $V_{CC} + 0.5V$
DC Input Voltage V_{IN}	-0.5V to 7.0V
DC Input Diode Current with $V_{IN} < 0$	-50mA
DC Output Diode Current	
$V_O < 0$	-50mA
$V_O > V_{CC}$	50mA
DC Output Source/Sink Current (I_{OH}/I_{OL})	$\pm 50mA$
DC Supply Current per Supply Pin	$\pm 100mA$
DC Ground Current per Ground Pin	$\pm 100mA$
T_{STG} Storage Temperature	-65° to 150°C

Note: Stresses greater than those listed under ABSOLUTE MAXIMUM RATINGS may cause permanent damage to QSI devices that result in functional or reliability type failures.

Table 5. Recommended Operating Conditions

Symbol	Parameter	Min	Max	Unit	
V_{CC}	Supply Voltage, Operating	2.0	3.6	V	
	Supply Voltage, Data Retention Only	1.5	3.6		
V_{IN}	Input Voltage	0	5.5	V	
V_{OUT}	Output Voltage in Active State	0	V_{CC}	V	
V_{OUT}	Output Voltage in "OFF" State	0	5.5	V	
I_{OH}/I_{OL}	Output Current	$V_{CC} = 3.0 - 3.6V$	—	± 24	mA
		$V_{CC} = 2.7V$	—	± 12	
$\Delta t/\Delta v$	Input Transition Slew Rate	—	10	ns/V	
T_A	Operating Free Air Temperature	-40	85	°C	

Table 6. DC Electrical Characteristics Over Operating Range

Industrial Temperature Range, $T_A = -40^{\circ}\text{C}$ to 85°C .

Symbol	Parameter	Test Conditions ⁽¹⁾	Min	Typ ⁽²⁾	Max	Unit
V_{IH}	Input HIGH Voltage	Logic HIGH for All Inputs	2.0	—	—	V
V_{IL}	Input LOW Voltage	Logic LOW for All Inputs	—	—	0.8	V
V_{OH}	Output HIGH Voltage	$V_{CC} = 2.7\text{V}$, $I_{OH} = -100\mu\text{A}$ $V_{CC} = 2.7\text{V}$, $I_{OH} = -12\text{mA}$ $V_{CC} = 3.0\text{V}$, $I_{OH} = -18\text{mA}$ $V_{CC} = 3.0\text{V}$, $I_{OH} = -24\text{mA}$	$V_{CC} - 0.2$ 2.2 2.4 2.2	— — — —	— — — —	V
V_{OL}	Output LOW Voltage	$V_{CC} = 2.7\text{V}$, $I_{OL} = 100\mu\text{A}$ $V_{CC} = 2.7\text{V}$, $I_{OL} = 12\text{mA}$ $V_{CC} = 3.0\text{V}$, $I_{OL} = 16\text{mA}$ $V_{CC} = 3.0\text{V}$, $I_{OL} = 24\text{mA}$	— — — —	— — — —	0.2 0.4 0.4 0.5	V
ΔV_T	Input Hysteresis ⁽³⁾	$V_{TLH} - V_{THL}$ for All Inputs	—	150	—	mV
$ I_{OZ} $	Off-State Output Current (Hi-Z)	$V_{CC} = 3.6\text{V}$, $V_{OUT} = 0\text{V}$, $V_{OUT} = 5.5\text{V}$	—	—	1	μA
I_{OS}	Short Circuit Current ^(3,4)	$V_{CC} = 3.6\text{V}$, $V_{OUT} = \text{GND}$	-60	—	-200	mA
V_{IK}	Input Clamp Voltage	$V_{CC} = 2.7\text{V}$, $I_{IN} = -18\text{mA}$	—	-0.7	-1.2	V
I_I	Input Leakage Current	$V_I = 0\text{V}$, $V_I = 5.5\text{V}$, $V_{CC} = 3.6\text{V}$	—	—	± 1.0	μA
$ I_{IBH} $	Input Current Input HIGH or LOW	$V_{CC} = 3.6\text{V}$ $V_{IN} = 0\text{V}$ or $V_{IN} = V_{CC}$	—	—	50	μA
	Bus Hold Inputs ^(3,5)	$V_{CC} = 3.6\text{V}$, $0.8 \leq V_{IN} \leq 2.0\text{V}$	—	—	500 ⁽⁶⁾	μA
I_{BHH}	Bus Hold Sustaining Current	$V_{CC} = 3.3\text{V}$	$V_{IN} = 2.0\text{V}$	-75	—	μA
I_{BHL}	Bus Hold Inputs		$V_{IN} = 0.8\text{V}$	75	—	μA
I_{OFF}	Power Off Leakage	$V_{CC} = 0\text{V}$, V_I or $V_O = 5.5\text{V}$	—	—	10	μA

Notes:

1. For conditions shown as Min. or Max. use appropriate value specified under Recommended Operating Conditions for the applicable device type.
2. Typical values are at $V_{CC} = 3.3\text{V}$ and $T_A = 25^{\circ}\text{C}$.
3. These parameters are guaranteed by characterization, but not production tested.
4. Not more than one output should be tested at one time. Duration of test should not exceed one second.
5. Pins with Bus Hold are identified in the Pin Description.
6. An external driver must provide at least $|I_{IBH}|$ during transition to guarantee that the Bus Hold input will change state.

Table 7. Power Supply Characteristics

Symbol	Parameter	Test Conditions ⁽¹⁾	Typ ⁽²⁾	Max	Unit	
I_{CC}	Quiescent Power Supply Current	$V_{CC} = 3.6V$ Freq = 0 $V_{IN} = GND$ or V_{CC}	0.1	10	μA	
ΔI_{CC}	Supply Current per Input @ TTL HIGH ⁽³⁾	$V_{CC} = 3.6V$	Control Inputs	2.0	30	μA
		$V_{IN} = V_{CC} - 0.6V$, Freq = 0	Bus Hold Inputs	—	500	
I_{CCD}	Supply Current per Input per MHz ⁽⁴⁾	$V_{CC} = 3.6V$ Outputs Open One Bit Toggling @ 50% Duty Cycle $x\bar{G} = GND$	50	75	$\mu A / MHz$	
I_C	Total Power Supply Current ⁽⁶⁾	$V_{CC} = 3.6V$ Outputs Open One Bit Toggling @ 50% Duty Cycle $x\bar{G} = GND$, $f = 10MHz$	$V_{IN} = V_{CC} - 0.6V$ $V_{IN} = GND$	0.5 ⁽⁵⁾	0.8 ⁽⁵⁾	mA
		$V_{CC} = 3.6V$ Outputs Open Eight Bits Toggling @ 50% Duty Cycle $x\bar{G} = GND$, $f = 2.5MHz$	$V_{IN} = V_{CC} - 0.6V$ $V_{IN} = GND$	1.0 ⁽⁵⁾	3.5 ⁽⁵⁾	mA

Notes:

- For conditions shown as Min. or Max., use the appropriate values specified under Recommended Operating Conditions for applicable device type.
- Typical values are at $V_{CC} = 3.3V$, 25°C ambient.
- Per TTL driven input. All other inputs at V_{CC} or GND.
- This parameter is not directly testable, but is derived for use in total power supply calculations.
- Values for these conditions are examples of the I_{CC} formula. These limits are guaranteed by design but not tested.
- $I_C = I_{QUIESCENT} + I_{INPUTS} + I_{DYNAMIC}$
 $I_C = I_{CCQ} + \Delta I_{CC} D_H N_T + I_{CCD} f N_O$
 $I_{CCQ} =$ Quiescent Current (I_{CCL} , I_{CCH} , and I_{CCZ}).
 $\Delta I_{CC} =$ Power Supply Current for a TTL-High Input ($V_{IN} = V_{CC} - 0.6V$).
 $D_H =$ Duty Cycle for TTL High Inputs.
 $N_T =$ Number of TTL High Inputs.
 $I_{CCD} =$ Dynamic Current Caused by an Input Transition Pair (HLH or LHL).
 $f =$ Average Switching Frequency per Output.
 $N_O =$ Number of Outputs Switching.

Table 8. Dynamic Switching Characteristics⁽¹⁾

Symbol	Parameter	Conditions	V_{CC} (V)	$T_A = 25^\circ C$	Units
				Typical	
V_{OLP}	Quiet Output Dynamic Peak V_{OL}	$C_L = 50pF$, $V_{IH} = 3.3V$, $V_{IL} = 0V$	3.3	0.8	V
V_{OLV}	Quiet Output Dynamic Valley V_{OL}	$C_L = 50pF$, $V_{IH} = 3.3V$, $V_{IL} = 0V$	3.3	0.8	V

Note:

- Characterized but not production tested.

Table 9. Switching Characteristics Over Operating Range

Industrial Temperature Range, $T_A = -40^{\circ}\text{C}$ to 85°C .

$C_{\text{LOAD}} = 50\text{pF}$, $R_{\text{LOAD}} = 500\Omega$ unless otherwise noted.

Symbol	Description ⁽¹⁾	H244				H244C		Unit
		$V_{\text{CC}} = 3.3 \pm 0.3\text{V}$		$V_{\text{CC}} = 2.7\text{V}^{(2)}$		$V_{\text{CC}} = 3.3 \pm 0.3\text{V}$		
		Min	Max	Min	Max	Min	Max	
t_{PHL} t_{PLH}	Propagation Delay Ai to Yi	1.5	6.5	1.5	7.5	1.5	4.1	ns
t_{PZH} t_{PZL}	Output Enable Time \overline{xG} to Yi	1.5	8.0	1.5	9.0	1.5	5.8	ns
t_{PHZ} t_{PLZ}	Output Disable Time ⁽²⁾ \overline{xG} to Yi	1.5	7.0	1.5	8.0	1.5	5.2	ns
$t_{\text{SK(O)}}$	Output Skew ⁽³⁾	—	0.5	—	—	—	0.5	ns

Notes:

1. Minimums guaranteed but not production tested. See test circuit and waveforms.
2. Guaranteed by characterization.
3. Skew between any two outputs of the same package switching in the same direction. This parameter is guaranteed by characterization but not production tested.

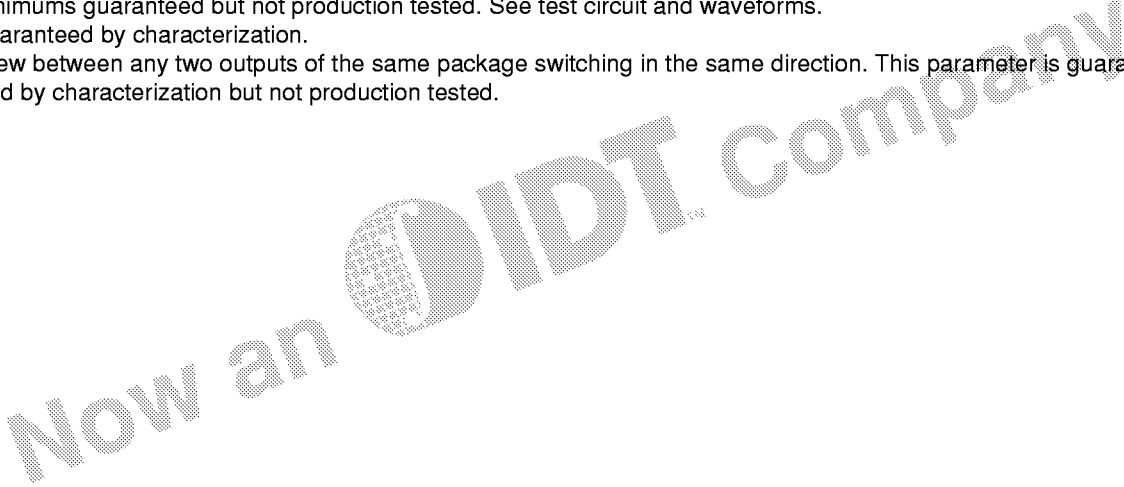

TEST CIRCUIT AND WAVEFORMS

Figure 3. Test Circuit

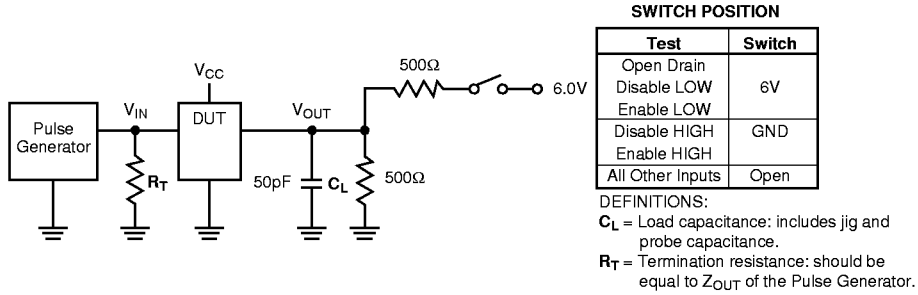

Figure 4. Setup, Hold, and Release Timing

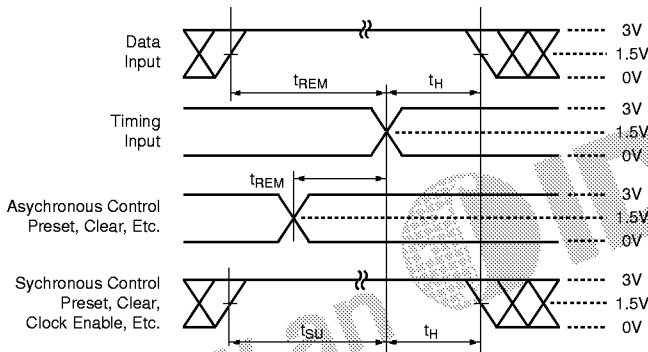

Figure 6. Pulse Width

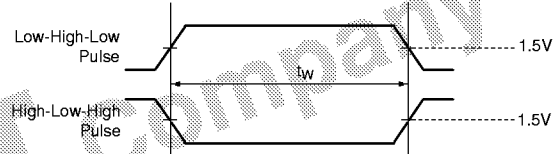

Figure 5. Enable and Disable Timing

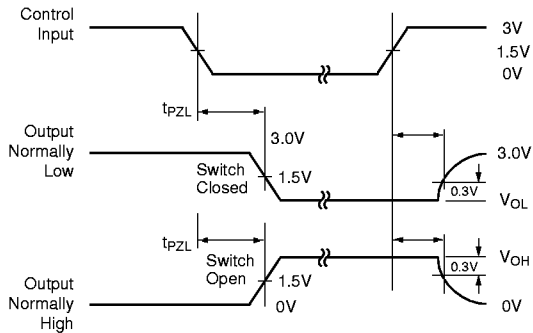
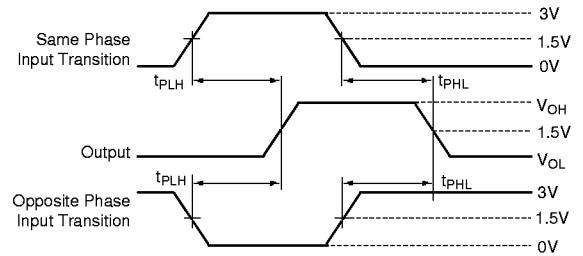

Figure 7. Propagation Delay



Notes:

1. Input Control Enable = LOW and Input Control Disable = HIGH.
2. Pulse Generator for All Pulses: Rate \leq 1.0MHz;
 $Z_{OUT} \leq 50\Omega$; $t_F, t_R \leq 2.5ns$.

ORDERING INFORMATION

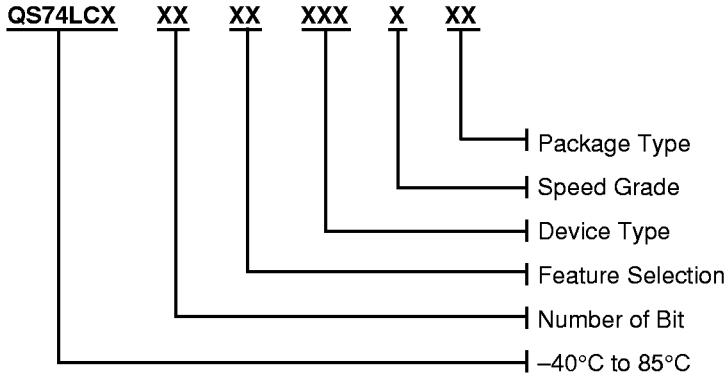

Device Type:

244

Speed Grades:

Blank – Standard
C

Package Type:

20-pin QSOP
20-pin SOIC

Feature Selection:

H – Bus Hold

Number of Bit:

Blank – 8-Bit

