

DV74ALS1003A

Quad 2-Input NAND Buffer with Open-Collector Outputs

This device contains four independent 2-input open buffers, each of which performs the logic NAND function.

- AVG's ALS has guaranteed DC and AC specification over full temperature and Vcc range
- Switching specifications for ALS at 50 pF
- AVG's ALS has the lowest speed power product (4pJ per gate typical) of all logic series
- Higher speed and 24mA Output Drive

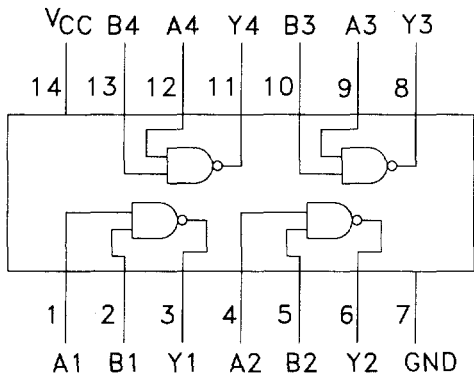
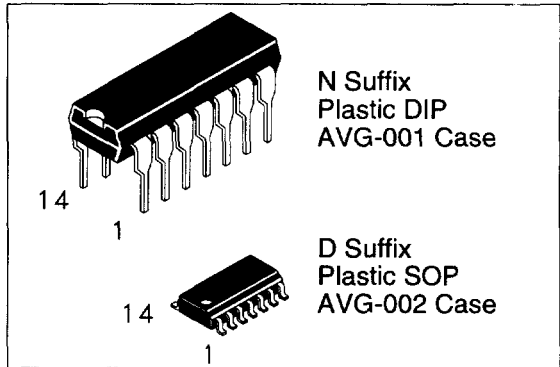

TRUTH TABLE
Y=AB

Inputs		Outputs
A	B	Y
L	L	H
L	H	H
H	L	H
H	H	L

H = High Level Logic
L = Low Level Logic

ABSOLUTE MAXIMUM RATINGS

Maximum ratings are those values beyond which damage to the device may occur.

Symbol	Parameter	D74ALS1003A	Unit
V _{CC}	Supply Voltage	7.0	V
V _{IN}	Input Voltage	7.0	V
T _{STG}	Storage Temperature Range	-65 to +150	°C

GUARANTEED OPERATING CONDITIONS

Symbol	Parameter	D74ALS1003A		Unit
		Min	Max	
V _{CC}	Supply Voltage	4.5	5.5	V
V _{IH}	High Level Input Voltage	2.0		V
V _{IL}	Low Level Input Voltage		0.8	V
V _{OH}	High Level Output Voltage		5.5	V
I _{OL}	Low Level Output Current		24	mA
T _A	Ambient Temperature Range	-10 to +70		°C

DC ELECTRICAL CHARACTERISTICS over full operating conditions

Symbol	Parameter	Conditions	ALS1003A			Unit
			Min	Typ	Max	
V _{IK}	Input Clamp Voltage	V _{CC} = min, I _{IN} = -18 mA			-1.5	V
I _{OH}	Output HIGH Current	V _{CC} = min, V _{OH} = 5.5V			100	μA
V _{OL}	Low Level Output Voltage	V _{CC} =min I _{OL} =12.0mA		0.25	0.4	V
			I _{OL} =24.0 mA		0.35	0.5
I _{IH}	High Level Input Current	V _{CC} =max, V _{IN} =2.7V			20	μA
		V _{CC} =max, V _{IN} = 7.0V			0.1	mA
I _{IL}	Low Level Input Current	V _{CC} =max, V _{IN} =0.4V			-0.1	mA
I _{CC}	Supply Current V _{CC} =max	Total, Output HIGH Total, Output LOW		0.86	1.6	mA
				4.8	7.8	mA

SWITCHING CHARACTERISTICS over full operating conditions

Symbol	Parameter	ALS1003A C _L = 50 pF R _L = 680Ω		Unit
		Min	Max	
t _{PLH}	Turn Off Delay, Input to Output	10	33	ns
t _{PHL}	Turn On Delay, Input to Output	2	12	ns

SWITCHING WAVEFORMS

