

HEX SCHMITT TRIGGERS

- SCHMITT-TRIGGER ACTION WITH NO EXTERNAL COMPONENTS
- HYSTERESIS VOLTAGE (TYP.) 0.9V AT $V_{DD} = 5V$, 2.3V AT $V_{DD} = 10V$ AND 3.5V AT $V_{DD} = 15V$
- NOISE IMMUNITY GREATER THAN 50%
- NO LIMIT ON INPUT RISE AND FALL TIME
- LOW V_{DD} TO V_{SS} CURRENT DURING SLOW INPUT RAMP
- STANDARDIZED SYMMETRICAL OUTPUT CHARACTERISTICS
- QUIESCENT CURRENT SPECIFIED AT 20V FOR HCC DEVICE
- 5V, 10V, AND 15V PARAMETRIC RATINGS
- INPUT CURRENT OF 100nA AT 18V AND 25°C FOR HCC DEVICE
- 100% TESTED FOR QUIESCENT CURRENT
- MEETS ALL REQUIREMENTS OF JEDEC TENTATIVE STANDARD N° 13A, "STANDARD SPECIFICATIONS FOR DESCRIPTION OF "B" SERIES CMOS DEVICES"

DESCRIPTION

The **HCC40106B** (extended temperature range) and **HCF40106B** (intermediate temperature range) are monolithic integrated circuits, available in 14-lead dual in-line plastic or ceramic package and plastic micropackage.

The **HCC/HCF40106B** consists of six Schmitt-trigger circuits. Each circuit functions as an inverter with Schmitt-trigger action on the input. The trigger switches at different points for positive and negative-going signals. The difference between the positive-going voltage (V_P) and the negative-going voltage (V_N) is defined as hysteresis voltage (V_H).

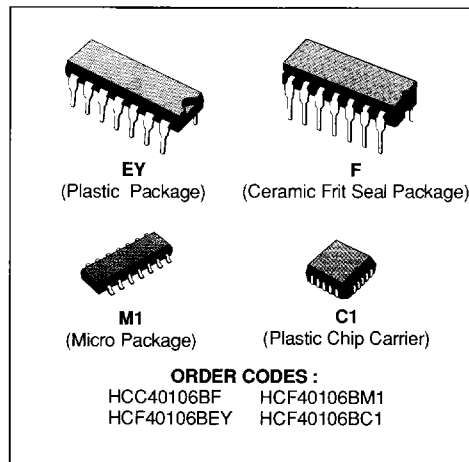

PIN CONNECTIONS

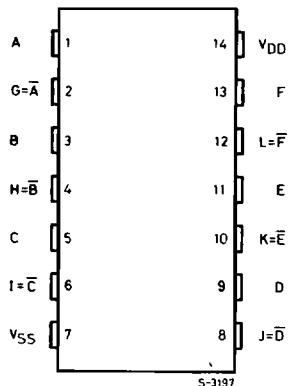

FUNCTIONAL DIAGRAM

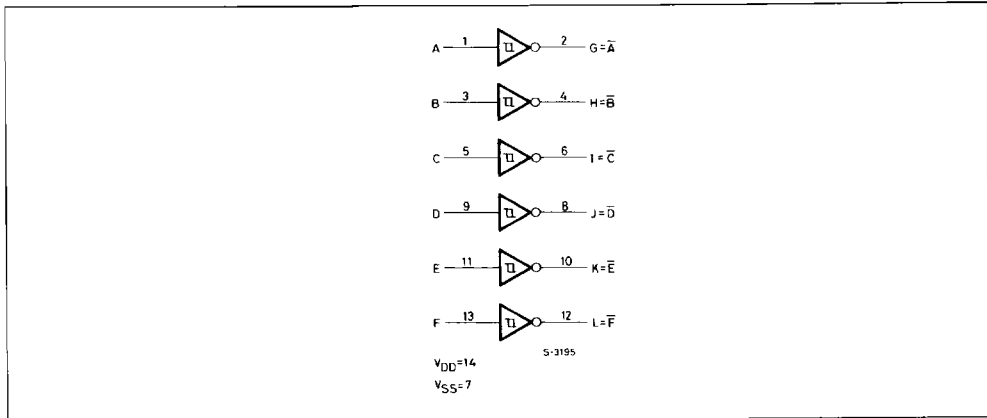

ABSOLUTE MAXIMUM RATINGS

Symbol	Parameter	Value	Unit
V _{DD} *	Supply Voltage : HCC Types	- 0.5 to + 20	V
	HCF Types	- 0.5 to + 18	V
V _i	Input Voltage	- 0.5 to V _{DD} + 0.5	V
I _I	DC Input Current (any one input)	± 10	mA
P _{tot}	Total Power Dissipation (per package)	200	mW
	Dissipation per Output Transistor for T _{op} = Full Package-temperature Range	100	mW
T _{op}	Operating Temperature : HCC Types	- 55 to + 125	°C
	HCF Types	- 40 to + 85	°C
T _{stg}	Storage Temperature	- 65 to + 150	°C

Stresses above those listed under "Absolute Maximum Ratings" may cause permanent damage to the device. This is a stress rating only and functional operation of the device at these or any other conditions above those indicated in the operational sections of this specification is not implied. Exposure to absolute maximum rating conditions for external periods may affect device reliability.

* All voltage values are referred to V_{SS} pin voltage.

RECOMMENDED OPERATING CONDITIONS

Symbol	Parameter	Value	Unit
V _{DD}	Supply Voltage : HCC Types	3 to 18	V
	HCF Types	3 to 15	V
V _I	Input Voltage	0 to V _{DD}	V
T _{op}	Operating Temperature : HCC Types	- 55 to + 125	°C
	HCF Types	- 40 to + 85	°C

LOGIC DIAGRAM

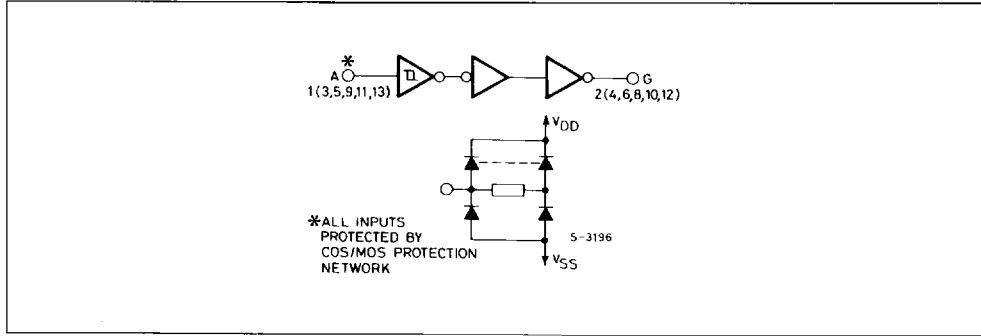

STATIC ELECTRICAL CHARACTERISTICS (over recommended operating conditions)

Symbol	Parameter	Test Conditions				Value						Unit				
		V _I (V)	V _O (V)	I _O (μ A)	V _{DD} (V)	T _{Low} *		25°C			T _{High} *					
						Min.	Max.	Min.	Typ.	Max.	Min.		Max.			
I _L	Quiescent Current				5	1		0.02	1		30	μ A				
						HCC Types	0/10			10			2	0.02	2	60
							0/15			15			4	0.02	4	120
							0/20			20			20	0.04	20	600
						HCF Types	0/5			5			4	0.02	4	30
							0/10			10			8	0.02	8	60
0/15			15		16		0.02	16	120							
V _{OH}	Output High Voltage				5	4.95		4.95			4.95	V				
						0/10			10		9.95			9.95		
						0/15			15		14.95			14.95		
V _{OL}	Output Low Voltage				5	0.05				0.05	0.05	V				
						10/0			10		0.05			0.05		
						15/0			15		0.05			0.05		
V _P	Positive Trigger Threshold Voltage				5	2.2	3.6	2.2	2.9	3.6	2.2	3.6	V			
						10	4.6	7.1	4.6	5.9	7.1	4.6		7.1		
						15	6.8	10.8	6.8	8.8	10.8	6.8		10.8		
V _N	Negative Trigger Threshold Voltage				5	0.9	2.8	0.9	1.9	2.8	0.9	2.8	V			
						10	2.5	5.2	2.5	3.9	5.2	2.5		5.2		
						15	4	7.4	4	5.8	7.4	4		7.4		
V _H	Hysteresis Voltage				5	0.3	1.6	0.3	0.9	1.6	0.3	1.6	V			
						10	1.2	3.4	1.2	2.3	3.4	1.2		3.4		
						15	1.6	5	1.6	3.5	5	1.6				

* T_{Low} = -55°C for HCC device ; -40°C for HCF device.* T_{High} = +125°C for HCC device ; +85°C for HCF device.

STATIC ELECTRICAL CHARACTERISTICS (continued)

Symbol	Parameter		Test Conditions				Value						Unit	
			V _I (V)	V _O (V)	I _O (μ A)	V _{DD} (V)	T _{Low} *		25°C			T _{High} *		
							Min.	Max.	Min.	Typ.	Max.	Min.		Max.
I _{OH}	Output Drive Current	HCC Types	0/5	2.5		5	-2		-1.6	-3.2		-1.15	mA	
			0/5	4.6		5	-0.64		-0.51	-1		-0.36		
			0/10	9.5		10	-1.6		-1.3	-2.6		-0.9		
			0/15	13.5		15	-4.2		-3.4	-6.8		-2.4		
		HCF Types	0/5	2.5		5	-1.53		-1.36	-3.2		-1.1		
			0/5	4.6		5	-0.52		-0.44	-1		-0.36		
			0/10	9.5		10	-1.3		-1.1	-2.6		-0.9		
			0/15	13.5		15	-3.6		-3.0	-6.8		-2.4		
I _{OL}	Output Sink Current	HCC Types	0/5	0.4		5	0.64		0.51	1		0.36	mA	
			0/10	0.5		10	1.6		1.3	2.6		0.9		
			0/15	1.6		15	4.2		3.4	6.8		2.4		
		HCF Types	0/5	0.4		5	0.52		0.44	1		0.36		
			0/10	0.5		10	1.3		1.1	2.6		0.9		
			0/15	1.5		15	3.6		3.0	6.8		2.9		
I _{IH} , I _{IL} **	Input Leakage Current	HCC Types	0/18	Any Input	18		± 0.1		$\pm 10^{-5}$	± 0.1		± 1	μ A	
		HCF Types	0/15		15		± 0.3		$\pm 10^{-5}$	± 0.3		± 1		
C _I	Input Capacitance		Any Input						5	7.5			p	

* T_{Low} = -55°C for HCC device ; -40°C for HCF device.* T_{High} = +125°C for HCC device ; +85°C for HCF device.

DYNAMIC ELECTRICAL CHARACTERISTICS (T_{amb} = 25°C, C_L = 50pF, R_L = 200k Ω , typical temperature coefficient for all V_{DD} values is 0.3%/°C, all input rise and fall time = 20ns)

Symbol	Parameter	Test Conditions		Value			Unit
			V _{DD} (V)	Min.	Typ.	Max.	
t _{PLH} , t _{PHL}	Propagation Delay Time		5		140	280	ns
			10		70	140	
			15		60	120	
t _{THL} , t _{TLH}	Transition Time		5		100	200	ns
			10		50	100	
			15		40	80	

HYSTERESIS DEFINITION, CHARACTERISTICS AND TEST SETUP

(a) Definition of V_P , V_N and V_H .

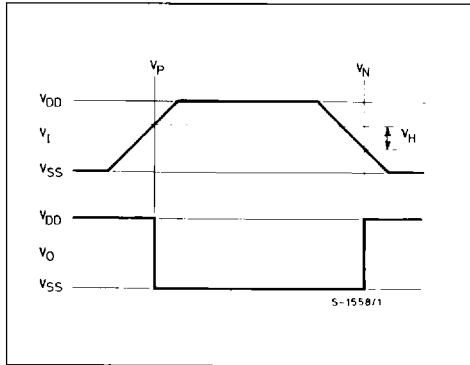

(b) Transfer Characteristic of 1 of 6 gates.

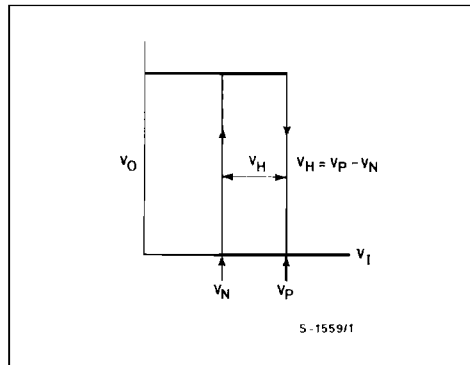

(c) Test Setup.

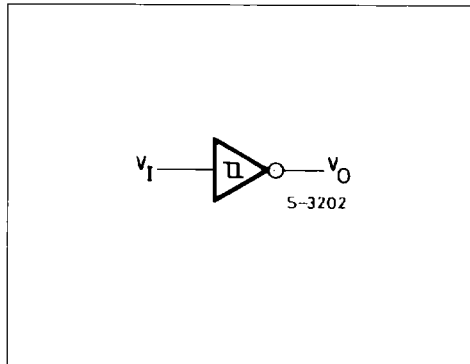

Input and Output Characteristics.

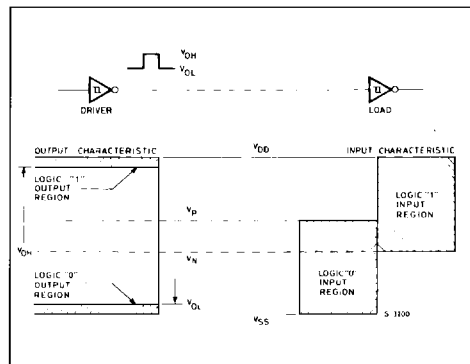

Typical Current Voltage Transfer Characteristics, and Test Circuit.

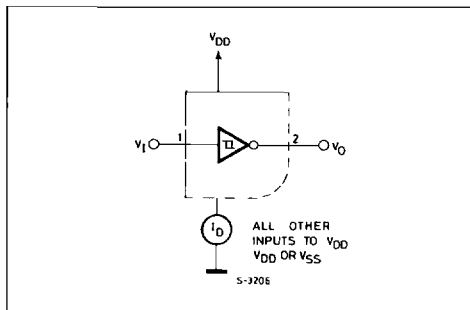
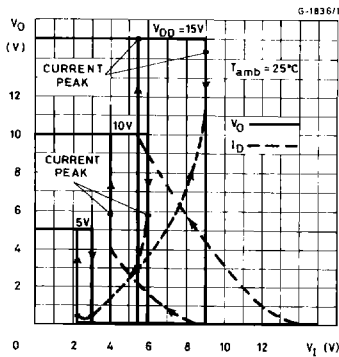

HYSTERESIS DEFINITION, CHARACTERISTICS AND TEST SETUP

Typical Voltage Transfer Characteristics vs. Temperature, and Test Circuit.

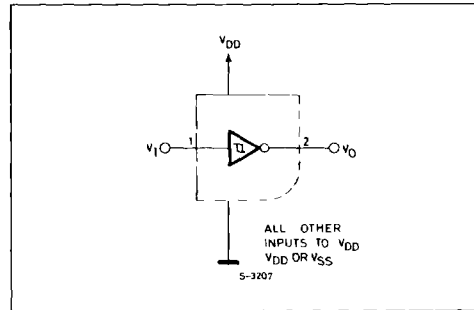
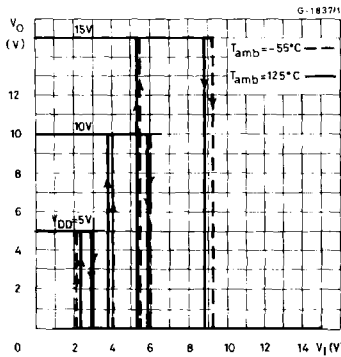

Typical Transition Time vs. Load Capacitance.

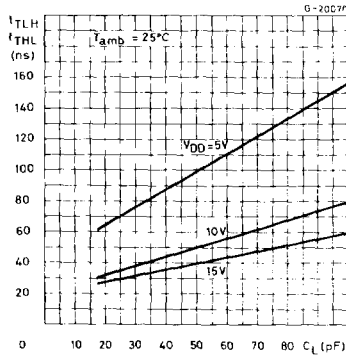

Output Low (sink) Current Characteristics.

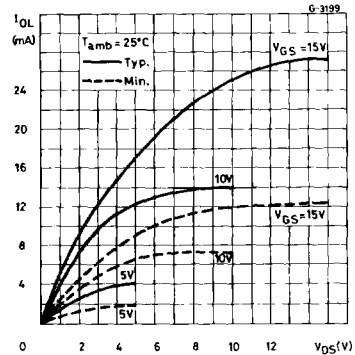

Output High (source) Current Characteristics.

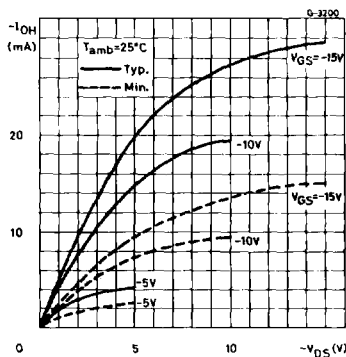

Typical Propagation Delay Time vs. Load Capacitance.

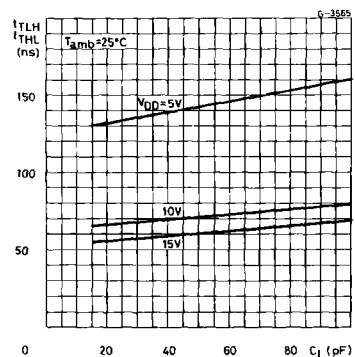

Typical Trigger Threshold Voltage vs. Supply Voltage .

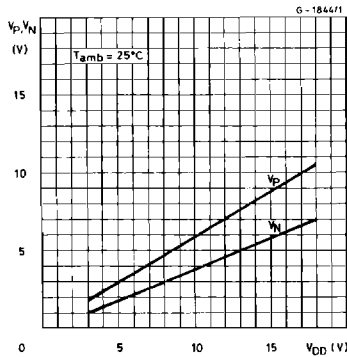

Typical per Cent Hysteresis vs. Supply Voltage.

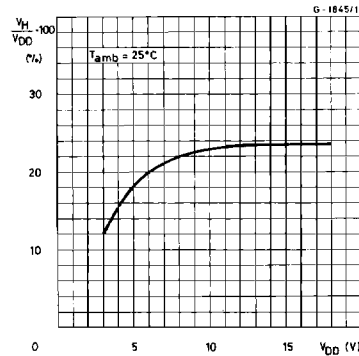

Typical Power Dissipation per Trigger vs. Input Frequency.

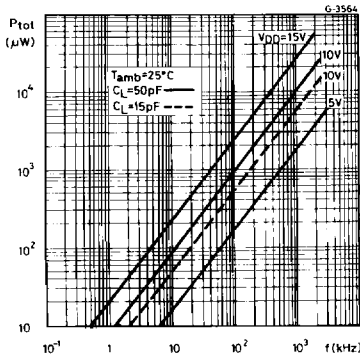

Typical Power Dissipation per Trigger vs. Input Frequency.

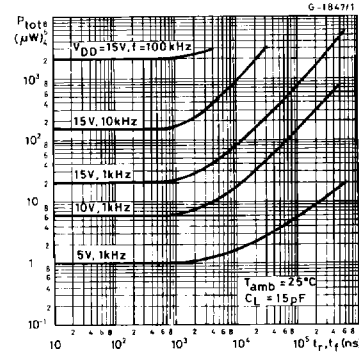

TYPICAL APPLICATIONS

ASTABLE MULTIVIBRATOR.

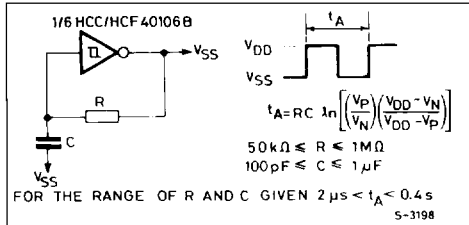

MONOSTABLE MULTIVIBRATOR.

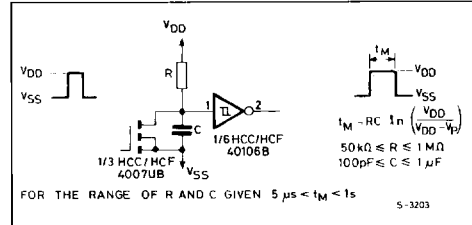

TYPICAL APPLICATIONS (continued)

WAVE SHAPER.

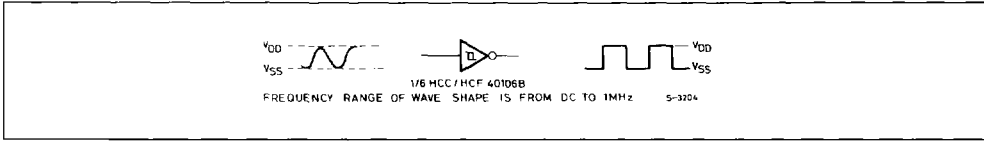

TEST CIRCUITS

Quiescent Device Current.

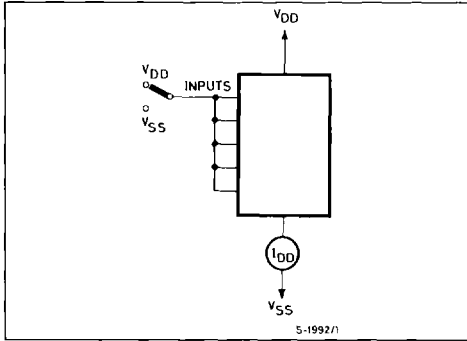

Dynamic Power Dissipation.

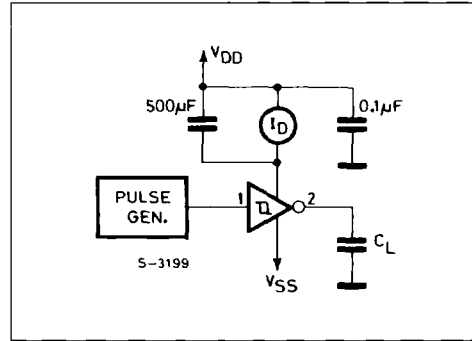

Input Current .

