



# LOW-VOLTAGE 12-BIT 1:2 MUX / DEMUX BUS SWITCH WITH INTERNAL PULL DOWN RESISTORS

**IDT74CBTLV16292**

## FEATURES:

- 5Ω A/B bi-directional switch
- Isolation Under Power-Off Conditions
- Make-before-break feature
- Over-voltage tolerant
- Internal 500Ω pull-down resistor to GND
- Latch-up performance exceeds 100mA
- V<sub>CC</sub> = 2.3V - 3.6V, normal range
- ESD >2000V per MIL-STD-883, Method 3015; >200V using machine model (C = 200pF, R = 0)
- Available in SSOP, TSSOP, and TVSOP packages

## APPLICATIONS:

- 3.3V High Speed Bus Switching and Bus Isolation
- Resource sharing

## DESCRIPTION:

The CBTLV16292 is a single 12-bit multiplexing / demultiplexing bus switch, which provides high speed switching. This device has very low ON resistance, resulting in under 250ps propagation delay through the switch. The demultiplexer side has a 500Ω resistor (R pull-down) termination to GND to eliminate floating nodes.

When the select (S) input is low, the A port is connected to the B1 port, and the R pull-down is connected to the B2 port. Similarly, when the S input is high, A port is connected to B2 port and the R pull-down is connected to B1 port.

## FUNCTIONAL BLOCK DIAGRAM

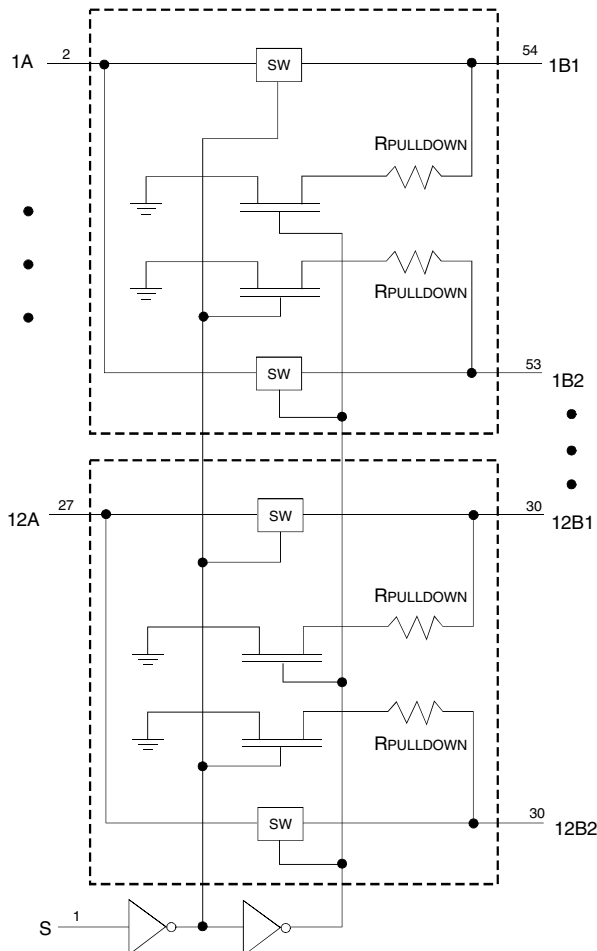

## SIMPLIFIED SCHEMATIC, EACH SWITCH

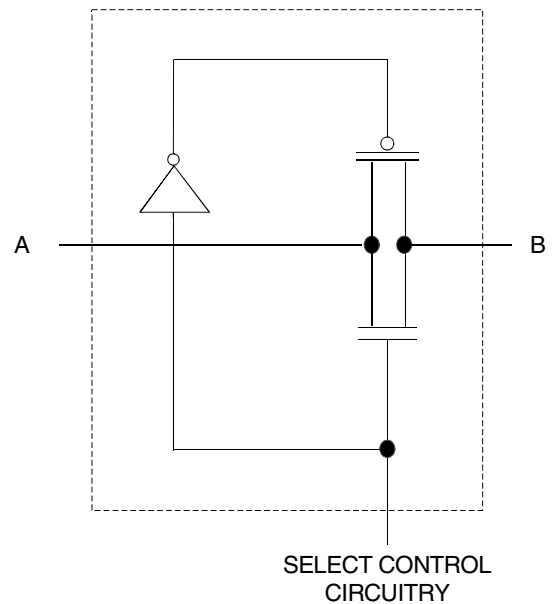

The IDT logo is a registered trademark of Integrated Device Technology, Inc.

INDUSTRIAL TEMPERATURE RANGE

AUGUST 2002

## PIN CONFIGURATION

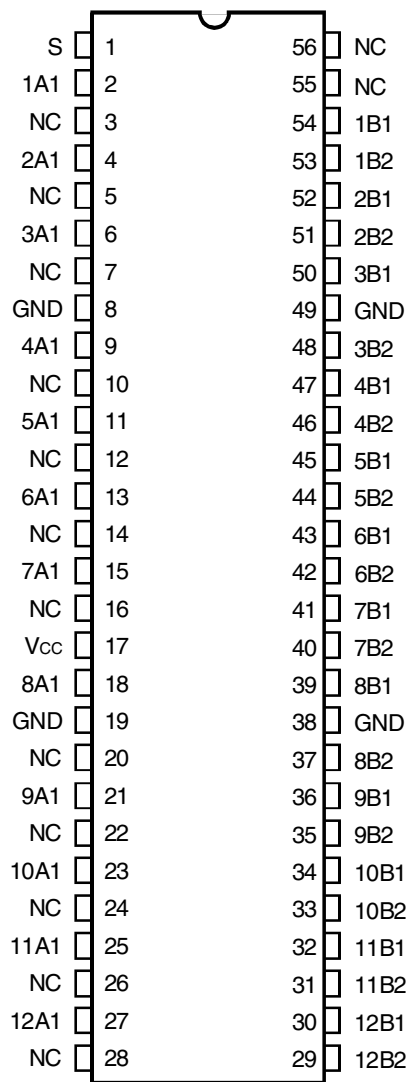

SSOP/ TSSOP/ TVSOP  
TOP VIEW

## ABSOLUTE MAXIMUM RATINGS<sup>(1)</sup>

Symbol	Description	Max.	Unit
V <sub>CC</sub>	Supply Voltage Range	-0.5 to 4.6	V
V <sub>I</sub>	Input Voltage Range	-0.5 to 4.6	V
	Continuous Channel Current	128	mA
I <sub>IK</sub>	Input Clamp Current, V <sub>I/O</sub> < 0	-50	mA
T <sub>STG</sub>	Storage Temperature Range	-65 to +150	°C

### NOTE:

- Stresses greater than those listed under ABSOLUTE MAXIMUM RATINGS may cause permanent damage to the device. This is a stress rating only and functional operation of the device at these or any other conditions above those indicated in the operational sections of this specification is not implied. Exposure to absolute maximum rating conditions for extended periods may affect reliability.

## PIN DESCRIPTION

Pin Names	Description
S	Select Input
x Ax	Port A Inputs or Outputs
x Bx	Port B Inputs or Outputs

## FUNCTION TABLE<sup>(1)</sup>

Input	Operation
S	
L	A Port = B1 Port R <sub>PULLDOWN</sub> = B2 Port
H	A Port = B2 Port R <sub>PULLDOWN</sub> = B1 Port

### NOTE:

- H = HIGH Voltage Level  
L = LOW Voltage Level

## OPERATING CHARACTERISTICS<sup>(1)</sup>

Symbol	Parameter	Test Conditions	Min.	Max.	Unit
V <sub>CC</sub>	Supply Voltage		2.3	3.6	V
V <sub>IH</sub>	High-Level Control Input Voltage	V <sub>CC</sub> = 2.3V to 2.7V	1.7	—	V
		V <sub>CC</sub> = 2.7V to 3.6V	2	—	
V <sub>IL</sub>	Low-Level Control Input Voltage	V <sub>CC</sub> = 2.3V to 2.7V	—	0.7	V
		V <sub>CC</sub> = 2.7V to 3.6V	—	0.8	
T <sub>A</sub>	Operating Free-Air Temperature		-40	+85	°C

### NOTE:

- All unused control inputs of the device must be held at V<sub>CC</sub> or GND to ensure proper device operation.

## DC ELECTRICAL CHARACTERISTICS OVER OPERATING RANGE

Following Conditions Apply Unless Otherwise Specified:

Operating Condition: TA = -40°C to +85°C

Symbol	Parameter	Test Conditions	Min.	Typ. <sup>(1)</sup>	Max.	Unit	
V <sub>IK</sub>	Control Inputs, Data I/O	V <sub>CC</sub> = 3V, I <sub>I</sub> = -18mA	—	—	-1.2	V	
I <sub>I</sub>	Control Inputs	V <sub>CC</sub> = 3.6V, V <sub>I</sub> = V <sub>CC</sub> or GND	—	—	±1	μA	
I <sub>OFF</sub>		V <sub>CC</sub> = 0V, V <sub>I</sub> or V <sub>O</sub> = 0V or 3.6V	—	—	10	μA	
I <sub>CC</sub>		V <sub>CC</sub> = 3.6V, I <sub>O</sub> = 0, V <sub>I</sub> = V <sub>CC</sub> or GND	—	—	10	μA	
ΔI <sub>CC</sub> <sup>(2)</sup>	Control Inputs	V <sub>CC</sub> = 3.6V, one input at 3V, other inputs at V <sub>CC</sub> or GND	—	—	300	μA	
C <sub>I</sub>	Control Inputs	V <sub>I</sub> = 3.3V or 0	—	3.5	—	pF	
C <sub>IO(OFF)</sub>	A port or B port	V <sub>O</sub> = 3.3V or 0	—	22.5	—	pF	
R <sub>ON</sub> <sup>(3)</sup>	Max. at V <sub>CC</sub> = 2.3V Typ. at V <sub>CC</sub> = 2.5V	V <sub>I</sub> = 0	I <sub>O</sub> = 64mA	—	5	8	Ω
			I <sub>O</sub> = 24mA	—	5	8	
		V <sub>I</sub> = 1.7V	I <sub>O</sub> = 15mA	—	11	40	
	V <sub>CC</sub> = 3V	V <sub>I</sub> = 0	I <sub>O</sub> = 64mA	—	3	7	
			I <sub>O</sub> = 24mA	—	3	7	
		V <sub>I</sub> = 2.4V	I <sub>O</sub> = 15mA	—	7	15	

### NOTES:

1. Typical values are at 3.3V, +25°C ambient.
2. The increase in supply current is attributable to each input that is at the specified voltage level rather than V<sub>CC</sub> or GND.
3. This is measured by the voltage drop between the A and B terminals at the indicated current through the switch.

## SWITCHING CHARACTERISTICS

Symbol	Parameter	V <sub>CC</sub> = 2.5V ± 0.2V		V <sub>CC</sub> = 3.3V ± 0.3V		Unit
		Min.	Max.	Min.	Max.	
t <sub>PD</sub> <sup>(1)</sup>	Propagation Delay A to B or B to A	—	0.15	—	0.25	ns
t <sub>PD</sub> <sup>(2)</sup>	Propagation Delay S to A	2.5	7.1	2.5	6.7	ns
t <sub>EN</sub>	Output Enable Time S to B	1	5.6	1	5	ns
t <sub>DIS</sub>	Output Disable Time S to B	1	5	1	4.5	ns
t <sub>MB/B</sub> <sup>(3,4)</sup>	Make-Before-Break Time	0	2	0	2	ns

### NOTES:

1. The propagation delay is the calculated RC time constant of the typical on-state resistance of the switch and the specified load capacitance when driven by an ideal voltage source (zero output impedance).
2. The condition to measure this propagation delay is by observing the change of voltage on the A port introduced by static fields equal to 3V or 0V for 3.3V±0.3V or V<sub>CC</sub> or 0 for 2.5V±0.2V on B1 and B2 ports to get the required transition.
3. The make-before-break time is the duration between the make and break, during transition from one selected port to another.
4. This parameter is guaranteed by design but not production tested.

## TEST CIRCUITS AND WAVEFORMS

### TEST CONDITIONS

Symbol	$V_{CC}^{(1)} = 3.3V \pm 0.3V$	$V_{CC}^{(2)} = 2.5V \pm 0.2V$	Unit
$V_{LOAD}$	6	$2 \times V_{CC}$	V
$V_{IH}$	3	$V_{CC}$	V
$V_T$	1.5	$V_{CC} / 2$	V
$V_{LZ}$	300	150	mV
$V_{HZ}$	300	150	mV
$C_L$	50	30	pF

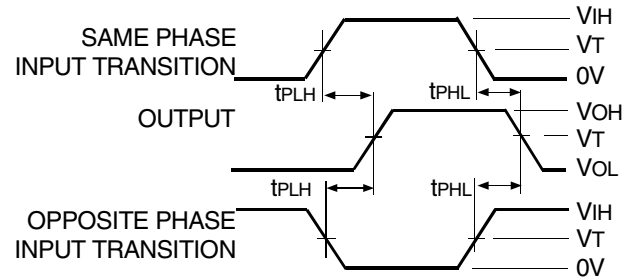

*Propagation Delay*

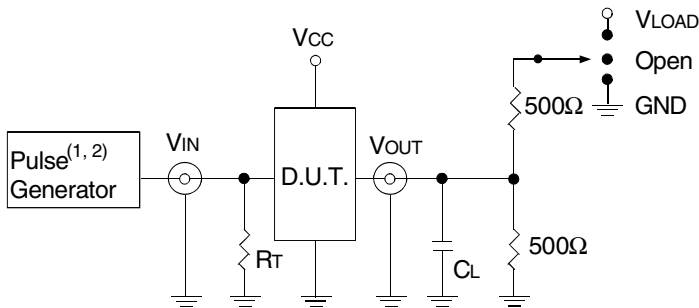

*Test Circuits for All Outputs*

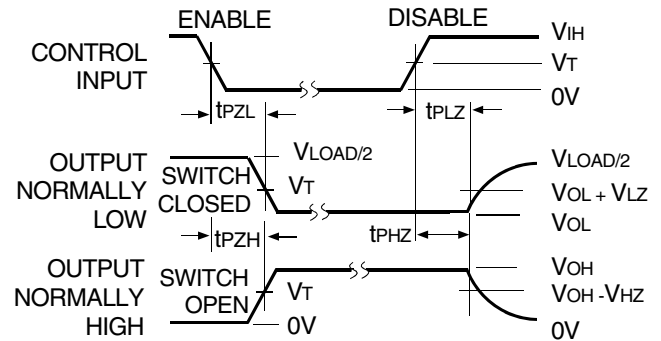

**NOTES:**

1. Diagram shown for input Control Enable-LOW and input Control Disable-HIGH.
2. Disable Low waveform applies to outputs that are LOW, except when disabled by the output control S.

*Enable and Disable Times*

**DEFINITIONS:**

$C_L$  = Load capacitance: includes jig and probe capacitance.  
 $R_T$  = Termination resistance: should be equal to  $Z_{out}$  of the Pulse Generator.

**NOTES:**

1. Pulse Generator for All Pulses: Rate  $\leq 10\text{MHz}$ ;  $t_r \leq 2.5\text{ns}$ ;  $t_f \leq 2.5\text{ns}$ .
2. Pulse Generator for All Pulses: Rate  $\leq 10\text{MHz}$ ;  $t_r \leq 2\text{ns}$ ;  $t_f \leq 2\text{ns}$ .

### SWITCH POSITION

Test	Switch
$t_{PLZ}/t_{PZL}$	$V_{LOAD}$
$t_{PHZ}/t_{PZH}$	GND
$t_{PD}$	Open

ORDERING INFORMATION

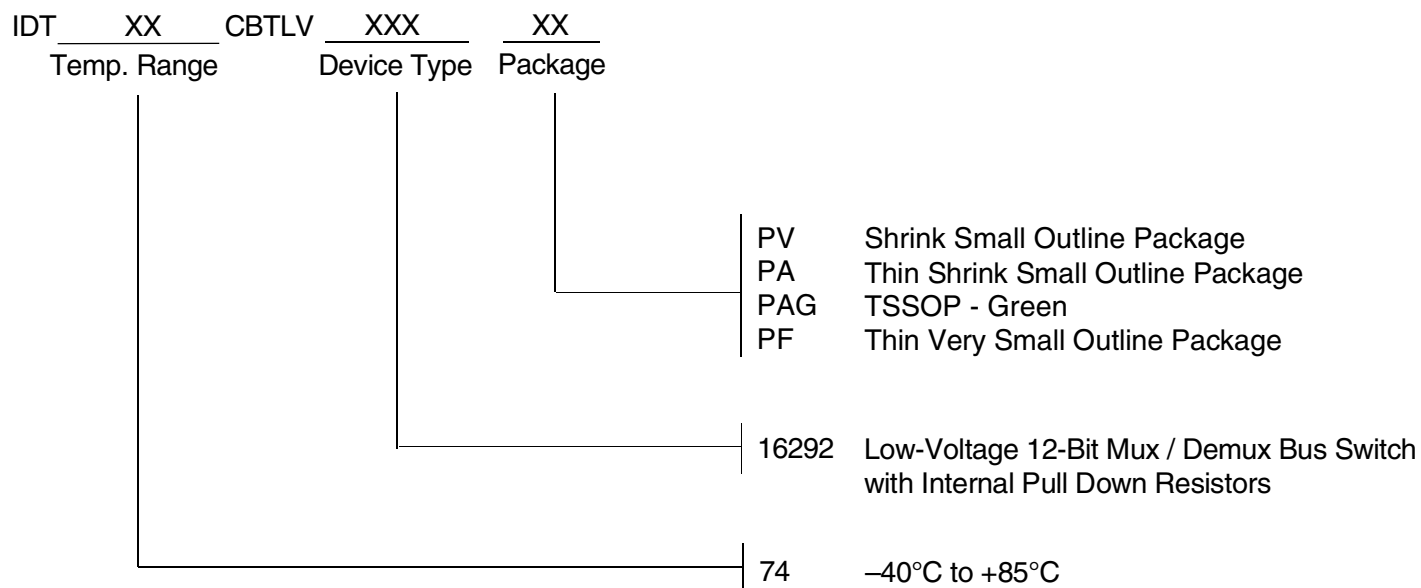

**CORPORATE HEADQUARTERS**  
 6024 Silver Creek Valley Road  
 San Jose, CA 95138

**for SALES:**  
 800-345-7015 or 408-284-8200  
 fax: 408-284-2775  
 www.idt.com

**for Tech Support:**  
 logichelp@idt.com