

HFM301 THRU HFM307

List

List.....	1
Package outline.....	2
Features.....	2
Mechanical data.....	2
Maximum ratings and Electrical characteristics	2
Rating and characteristic curves.....	3
Pinning information.....	4
Marking.....	4
Suggested solder pad layout.....	4
Packing information.....	5
Reel packing.....	6
Suggested thermal profiles for soldering processes.....	6
High reliability test capabilities.....	7

HFM301 THRU HFM307

3.0A Surface Mount High Efficiency Rectifiers 50V-1000V

Features

- Batch process design, excellent power dissipation offers better reverse leakage current and thermal resistance
- Low profile surface mounted application in order to optimize board space
- High current capability
- Ultrafast recovery time for high efficiency
- High surge current capability
- Glass passivated chip junction
- Lead-free parts meet RoHS requirements
- Suffix "-H" indicates Halogen free parts, ex. HFM301-H

Mechanical data

- Epoxy:UL94-V0 rated flame retardant
- Case : Molded plastic, SMC
- Terminals : Solder plated, solderable per MIL-STD-750, Method 2026
- Polarity : Indicated by cathode band
- Mounting Position : Any
- Weight : Approximated 0.19 gram

Package outline

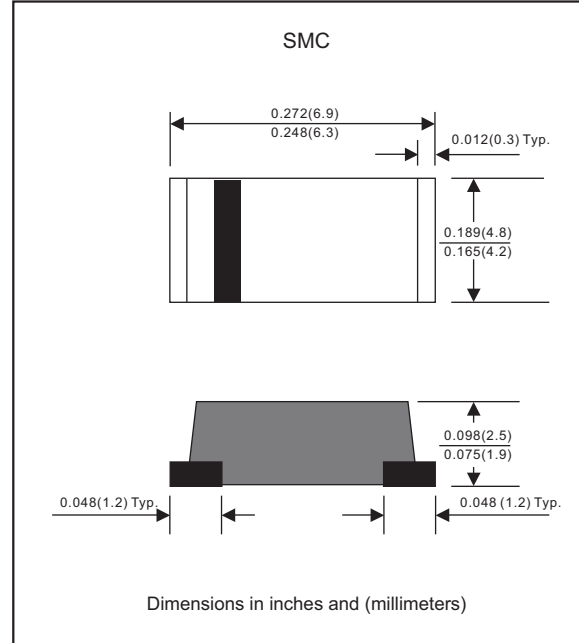

Maximum ratings (AT $T_A=25^{\circ}\text{C}$ unless otherwise noted)

PARAMETER	SYMBOLS	HFM301	HFM302	HFM303	HFM304	HFM305	HFM306	HFM307	UNIT
Maximum repetitive peak reverse voltage	V_{RRM}	50	100	200	400	600	800	1000	V
Maximum RMS voltage	V_{RMS}	35	70	140	280	420	560	700	V
Maximum continuous reverse voltage	V_R	50	100	200	400	600	800	1000	V
Maximum average forward rectified current	I_o	3.0							A
Non-repetitive peak forward surge current 8.3ms single half sine-wave	I_{FSM}	100							A
Typical junction capacitance (Note 1)	C_J	70							pF
Operating junction temperature range	T_J	-55 to +150							$^{\circ}\text{C}$
Storage temperature range	T_{STG}	-65 to +175							$^{\circ}\text{C}$

Electrical characteristics (AT $T_A=25^{\circ}\text{C}$ unless otherwise noted)

PARAMETER	SYMBOLS	HFM301	HFM302	HFM303	HFM304	HFM305	HFM306	HFM307	UNIT	
Maximum instantaneous forward voltage at $I_F=3.0\text{A}$	V_F	1.00			1.30	1.70			V	
Maximum reverse leakage current $T_J=25^{\circ}\text{C}$ at rated V_R $T_J=125^{\circ}\text{C}$	I_R	5.0				300				μA μA
Maximum reverse recovery time (Note 2)	t_{rr}	50				75				ns

Thermal characteristics

PARAMETER	SYMBOLS	HFM301	HFM302	HFM303	HFM304	HFM305	HFM306	HFM307	UNIT
Typical thermal resistance junction to ambient (Note 3)	$R_{\theta JA}$	48							$^{\circ}\text{C}/\text{W}$
Typical thermal resistance junction to case (Note 3)	$R_{\theta JC}$	33							$^{\circ}\text{C}/\text{W}$

Notes 1: Measured at 1 MHz and applied reverse voltage of 4.0 VDC

2: Measured with $I_F = 0.5\text{A}$, $I_R = 1\text{A}$, $I_{rr} = 0.25\text{A}$

3: Mounted on FR-4 PCB Copper, minimum recommended pad layout



Rating and characteristic curves (HFM301 THRU HFM307)

FIG.1-TYPICAL FORWARD CHARACTERISTICS

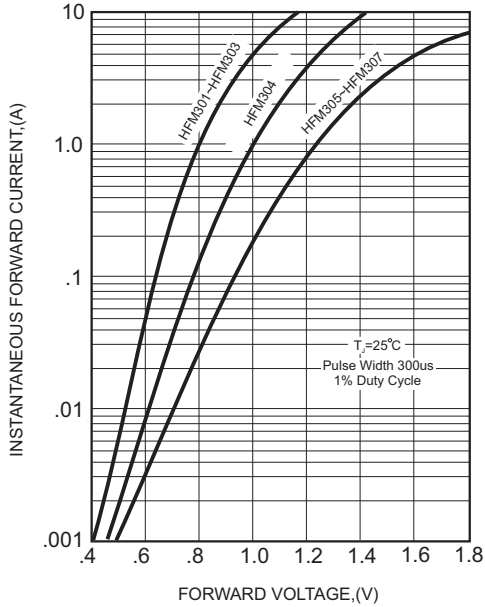

FIG.2-TYPICAL FORWARD CURRENT DERATING CURVE

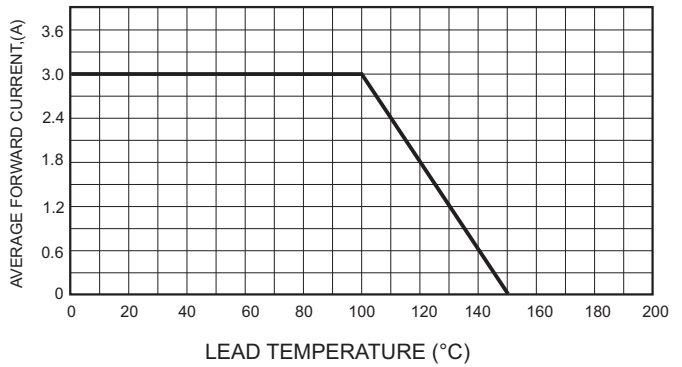

FIG.4-MAXIMUM NON-REPETITIVE FORWARD SURGE CURRENT

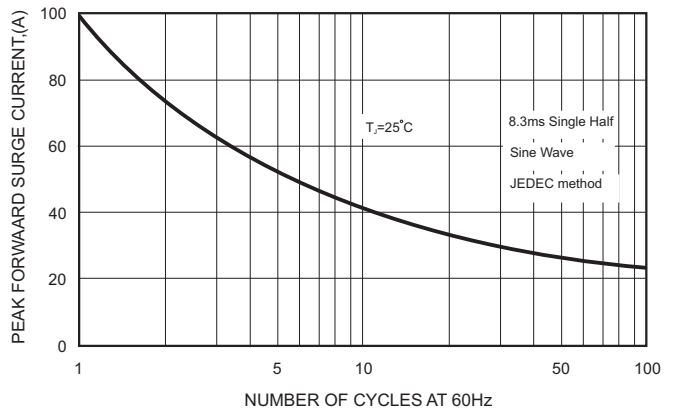
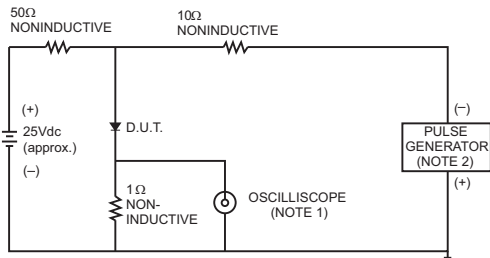

FIG.3- TEST CIRCUIT DIAGRAM AND REVERSE RECOVERY TIME CHARACTERISTICS



NOTES: 1. Rise Time = 7ns max., Input Impedance = 1 megohm, 22pF.
2. Rise Time = 10ns max., Source Impedance = 50 ohms.

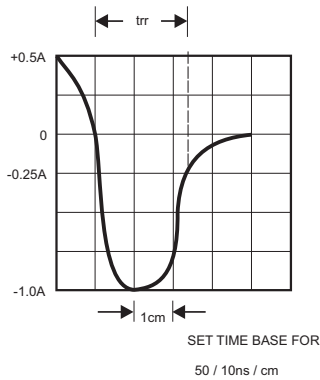
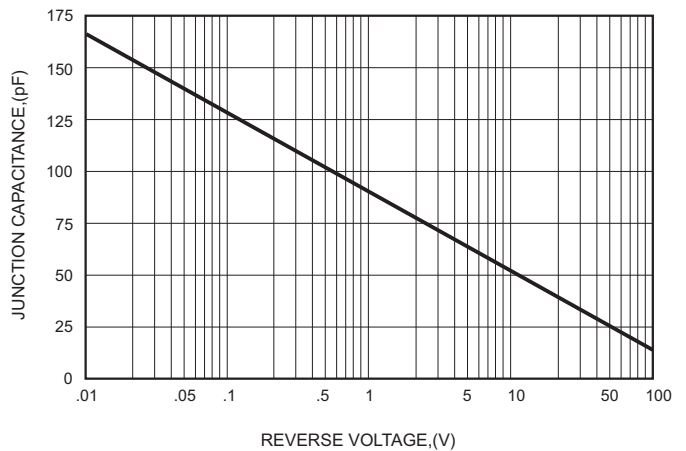



FIG.5-TYPICAL JUNCTION CAPACITANCE



HFM301 THRU HFM307

Pinning information

Pin	Simplified outline	Symbol
Pin1 cathode Pin2 anode		

Marking

Type number	Marking code
HFM301	H31
HFM302	H32
HFM303	H33
HFM304	H34
HFM305	H35
HFM306	H36
HFM307	H37

Suggested solder pad layout

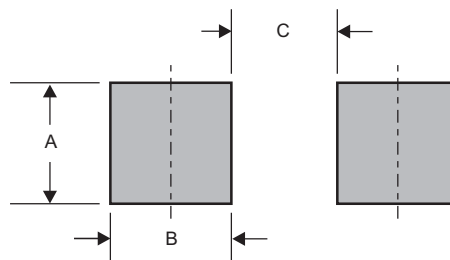

Dimensions in inches and (millimeters)

PACKAGE	A	B	C
SMC	0.189 (4.80)	0.063 (1.60)	0.158 (4.00)

HFM301 THRU HFM307

Packing information

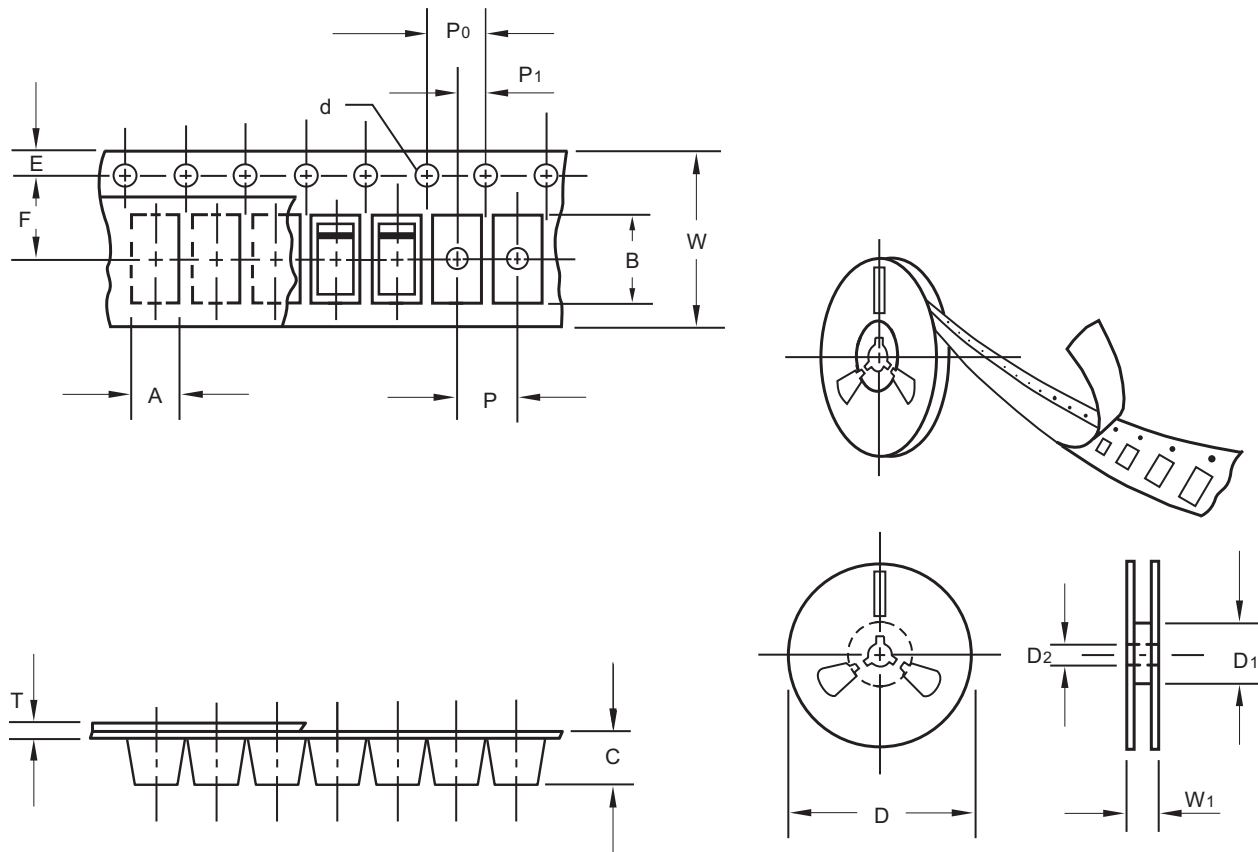

unit:mm

Item	Symbol	Tolerance	SMC
Carrier width	A	0.1	5.10
Carrier length	B	0.1	7.20
Carrier depth	C	0.1	2.50
Sprocket hole	d	0.1	1.50
13" Reel outside diameter	D	2.0	330.00
13" Reel inner diameter	D1	min	50.00
7" Reel outside diameter	D	2.0	178.00
7" Reel inner diameter	D1	min	62.00
Feed hole diameter	D2	0.5	13.00
Sprocket hole position	E	0.1	1.75
Punch hole position	F	0.1	5.50
Punch hole pitch	P	0.1	8.00
Sprocket hole pitch	P0	0.1	4.00
Embossment center	P1	0.1	2.00
Overall tape thickness	T	0.1	0.23
Tape width	W	0.3	12.00
Reel width	W1	1.0	18.00

Note: Devices are packed in accordance with EIA standard RS-481-A and specifications listed above.

HFM301 THRU HFM307

Reel packing

PACKAGE	REEL SIZE	REEL (pcs)	COMPONENT SPACING (m/m)	BOX (pcs)	INNER BOX (m/m)	REEL DIA, (m/m)	CARTON SIZE (m/m)	CARTON (pcs)	APPROX. GROSS WEIGHT (kg)
SMC	13"	3,000	8.0	6,000	335*335*38	330	350*330*360	48,000	17.0

Suggested thermal profiles for soldering processes

- 1.Storage environment: Temperature=5°C~40°C Humidity=55%±25%
- 2.Reflow soldering of surface-mount devices

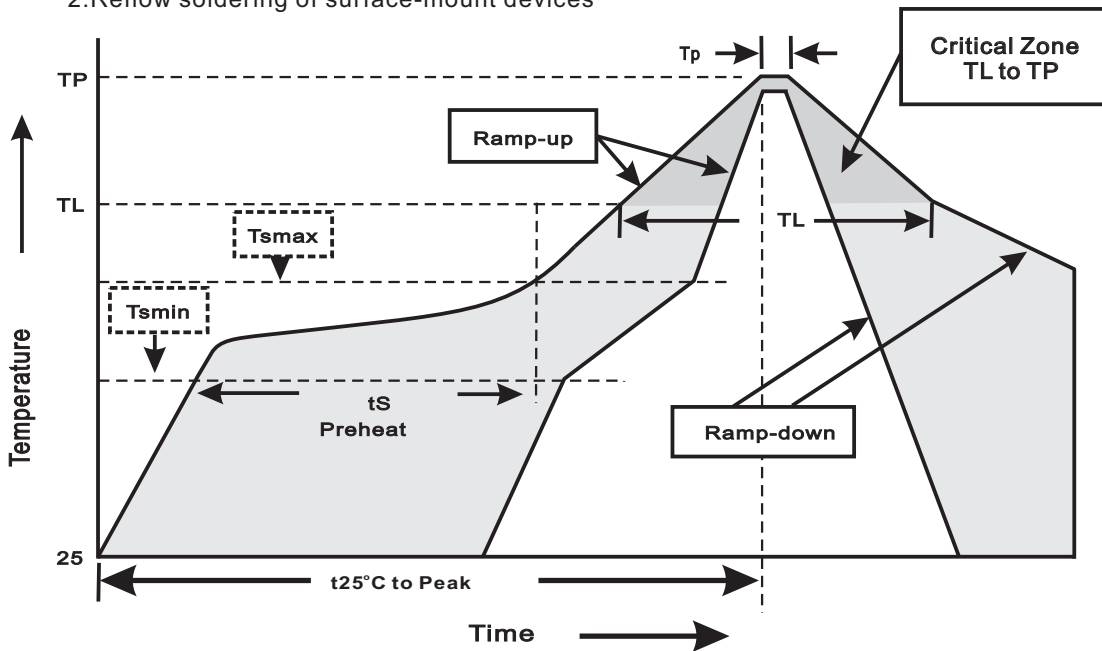

3.Reflow soldering

Profile Feature	Soldering Condition
Average ramp-up rate(TL to TP)	<3°C/sec
Preheat -Temperature Min(Tsmin) -Temperature Max(Tsmax) -Time(min to max)(ts)	150°C 200°C 60~120sec
Tsmax to TL -Ramp-upRate	<3°C/sec
Time maintained above: -Temperature(TL) -Time(tL)	217°C 60~260sec
Peak Temperature(TP)	255°C-0/+5°C
Time within 5°C of actual Peak Temperature(tp)	10~30sec
Ramp-down Rate	<6°C/sec
Time 25°C to Peak Temperature	<6minutes

HFM301 THRU HFM307**High reliability test capabilities**

Item Test	Conditions	Reference
1. Solder Resistance	at 260±5°C for 10±2sec.	MIL-STD-750D METHOD-2031
2. Solderability	at 245±5°C for 5 sec.	MIL-STD-202F METHOD-208
3. High Temperature Reverse Bias	$V_R=80\%$ rate at $T_J=150^\circ\text{C}$ for 168 hrs.	MIL-STD-750D METHOD-1038
4. Forward Operation Life	Rated average rectifier current at $T_A=25^\circ\text{C}$ for 500hrs.	MIL-STD-750D METHOD-1027
5. Intermittent Operation Life	$T_A = 25^\circ\text{C}$, $I_F = I_O$ On state: power on for 5 min. off state: power off for 5 min. on and off for 500 cycles.	MIL-STD-750D METHOD-1036
6. Pressure Cooker	15P _{SIG} at $T_A=121^\circ\text{C}$ for 4 hrs.	JESD22-A102
7. Temperature Cycling	-55°C to +125°C dwelled for 30 min. and transferred for 5min. total 10 cycles.	MIL-STD-750D METHOD-1051
8. Forward Surge	8.3ms single half sine-wave , one surge.	MIL-STD-750D METHOD-4066-2
9. Humidity	at $T_A=85^\circ\text{C}$, RH=85% for 1000hrs.	MIL-STD-750D METHOD-1021
10. High Temperature Storage Life	at 175°C for 1000 hrs.	MIL-STD-750D METHOD-1031