



M54HCT240/241/244

M74HCT240/241/244

HCT240 OCTAL BUS BUFFER WITH INVERTED 3-STATE OUTPUTS

HCT241/4 OCTAL BUS BUFFER WITH NON-INVERTED 3-STATE OUTPUTS

- HIGH SPEED
 $t_{PD} = 20$ ns (TYP.) at $V_{CC} = 5$ V
- LOW POWER DISSIPATION
 $I_{CC} = 4$ μ A (MAX.) at $T_A = 25^\circ$ C
- COMPATIBLE WITH TTL OUTPUTS
 $V_{IH} = 2$ V (MIN.), $V_{IL} = 0,8$ V (MAX)
- OUTPUT DRIVE CAPABILITY
15 LSTTL LOADS
- SYMMETRICAL OUTPUT IMPEDANCE
 $|I_{OH}| = I_{OL} = 6$ mA (MIN.)
- BALANCED PROPAGATION DELAYS
 $t_{PLH} = t_{PHL}$
- PIN AND FUNCTION COMPATIBLE
WITH 54/74LS240/241/244

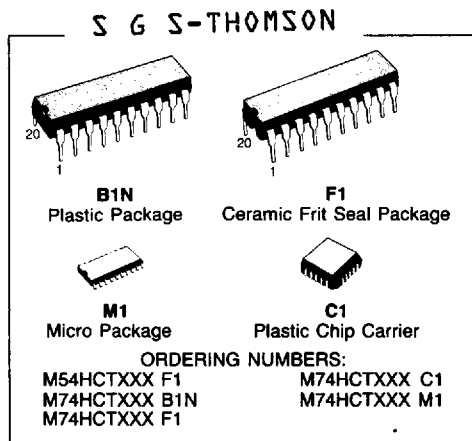

DESCRIPTION

The HCT240, HCT241 and HCT244 are high speed CMOS OCTAL BUS BUFFER's fabricated with silicon C²MOS technology.

These devices may be used as a level converter for interfacing TTL or NMOS to High Speed CMOS. The inputs are compatible with TTL, NMOS and CMOS output voltage levels.

They achieve the high speed operation similar to equivalent LSTTL while maintaining the CMOS low power dissipation.

The designer has a choice of selected combinations of inverting and noninverting outputs, symmetrical \bar{G} (active-low output control) inputs, and complementary G and \bar{G} inputs. Each control input governs four BUS BUFFERS.

These devices are designated to be used with 3-state memory address drivers, etc. All inputs are equipped with protection circuits against static discharge and transient excess voltage.

PIN CONNECTIONS (top view)

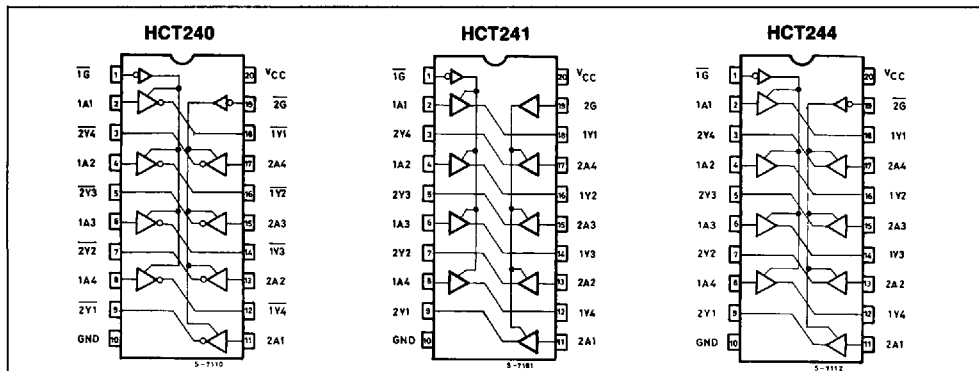

CHIP CARRIER

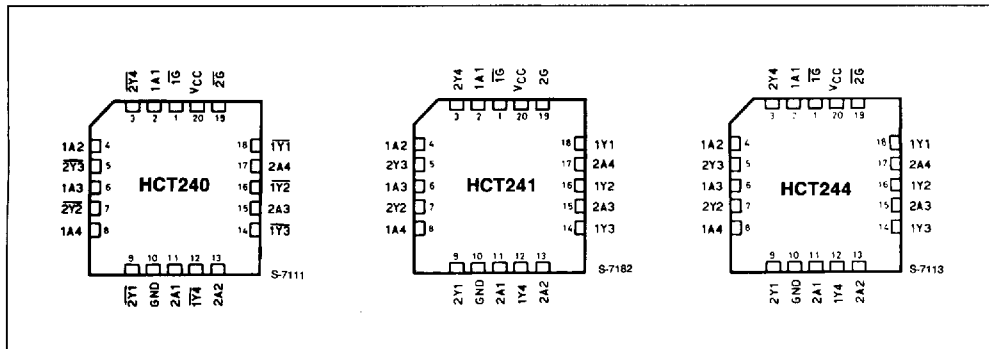

INPUT AND OUTPUT EQUIVALENT CIRCUIT

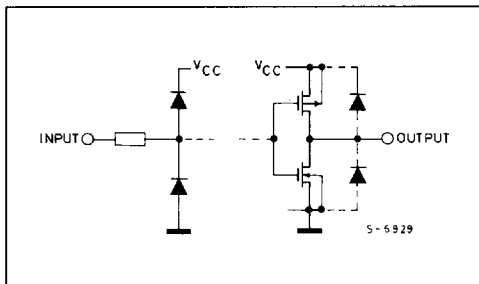

TRUTH TABLE

INPUTS			OUTPUTS	
\bar{G}	G^{Δ}	A_n	Y_n	$\bar{Y}_n^{\Delta \Delta}$
L	H	L	L	H
L	H	H	H	L
H	L	X	Z	Z

Δ : APPLIED ONLY FOR M54/74HCT241
 $\Delta \Delta$: APPLIED ONLY FOR M54/74HCT240
 X: DON'T CARE
 Z: HIGH IMPEDANCE

ABSOLUTE MAXIMUM RATINGS

Symbol	Parameter	Value	Unit
V_{CC}	Supply Voltage	-0.5 to 7	V
V_I	DC Input Voltage	-0.5 to $V_{CC} + 0.5$	V
V_O	DC Output Voltage	-0.5 to $V_{CC} + 0.5$	V
I_{IK}	DC Input Diode Current	± 20	mA
I_{OK}	DC Output Diode Current	± 20	mA
I_O	DC Output Source Sink Current Per Output Pin	± 35	mA
I_{CC} or I_{GND}	DC V_{CC} or Ground Current	± 70	mA
PD	Power Dissipation	500 (*)	mW
T_{stg}	Storage Temperature	-65 to 150	$^{\circ}C$

Absolute Maximum Ratings are those values beyond which damage to the device may occur. Functional operation under these condition is not implied.

(*) 500 mW: $\cong 65^{\circ}C$ derate to 300 mW by 10 mW/ $^{\circ}C$: 65 $^{\circ}C$ to 85 $^{\circ}C$

S G S-THOMSON

RECOMMENDED OPERATING CONDITIONS

Symbol	Parameter	Value	Unit
V_{CC}	Supply Voltage	4.5 to 5.5	V
V_I	Input Voltage	0 to V_{CC}	V
V_O	Output Voltage	0 to V_{CC}	V
T_A	Operating Temperature 74HC Series 54HC Series	- 40 to 85 - 55 to 125	°C
t_r, t_f	Input Rise and Fall Time	0 to 500	ns

DC SPECIFICATIONS

Symbol	Parameter	V_{CC}	Test Condition	$T_A = 25^\circ\text{C}$ 54HC and 74HC			-40 to 85°C 74HC		-55 to 125°C 54HC		Unit	
				Min.	Typ.	Max.	Min.	Max.	Min.	Max.		
V_{IH}	High Level Input Voltage	4.5 to 5.5		2.0	—	—	2.0	—	2.0	—	V	
V_{IL}	Low Level Input Voltage	4.5 to 5.5		—	—	0.8	—	0.8	—	0.8	V	
V_{OH}	High Level Output Voltage	4.5	V_{IN}	I_{OH} - 20 μA	4.4	4.5	—	4.4	—	4.4	—	V
			V_{IH} or V_{IL}									
V_{OL}	Low Level Output Voltage	4.5	V_{IN}	I_{OL} 20 μA	—	0.0	0.1	—	0.1	—	0.1	V
			V_{IH} or V_{IL}									
I_{OZ}	3-State Output Off-State Current	5.5	$V_{IN} = V_{IH}$ or V_{IL} $V_{OUT} = V_{CC}$ or GND	—	—	± 0.5	—	± 5.0	—	± 10.0	μA	
I_{IN}	Input Leakage Current	5.5	$V_{IN} = V_{CC}$ or GND	—	—	± 0.1	—	± 1.0	—	± 1.0		
I_{CC}	Quiescent Supply Current	5.5	$V_I = V_{CC}$ or GND	—	—	4.0	—	40.0	—	80.0		
I_{CC}	Quiescent Supply Current	5.5	Per input: $V_{IN} = 0.5\text{V}$ or 2.4V Other input: V_{CC} or GND	—	—	2.0	—	2.9	—	3.0	mA	

AC ELECTRICAL CHARACTERISTICS ($C_L = 50\text{pF}$, Input $t_r = t_f = 6\text{ns}$)

S G S-THOMSON

Symbol	Parameter	Test Condition	$T_A = 25^\circ\text{C}$				-40 to 85°C		-55 to 125°C		Unit
			V_{CC}	Min.	Typ.	Max.	Min.	Max.	Min.	Max.	
t_{TLH} t_{TLH}	Output Transition Time		4.5	—	8	12	—	15	—	19	ns
t_{PLH} t_{PHL}	Propagation Delay Time (HCT240)		4.5	—	22	35	—	42	—	53	ns
t_{PLH} t_{PHL}	Propagation Delay Time (HCT241, HCT244)		4.5	—	23	36	—	44	—	54	ns
t_{PZL} t_{PZH}	Output Enable Time	$R_L = 1\text{k}\Omega$	4.5	—	23	35	—	43	—	53	ns
t_{PLZ} t_{PHZ}	Output Disable Time	$R_L = 1\text{k}\Omega$	4.5	—	30	47	—	57	—	71	ns
C_{IN}	Input Capacitance			—	5	10	—	10		10	pF
C_{OUT}	Output Capacitance			—	10	—	—	—	—	—	pF
$C_{PD(1)}$	Power Dissipation Capacitance	HCT240		—	42	—	—	—	—	—	pF
		HCT241		—	49	—	—	—	—	—	
		HCT244		—	46	—	—	—	—	—	

Note (1) C_{PD} is defined as the value of IC's of internal equivalent capacitance which is calculated from the operating current consumption without load. (Refer to Test Circuit)

Average operating current can be obtained by the following equation.

$$I_{CC(\text{opr})} = C_{PD} \cdot V_{CC} \cdot f_{IN} + I_{CC}/8 \text{ (per Gate)}$$

CIRCUIT DIAGRAM

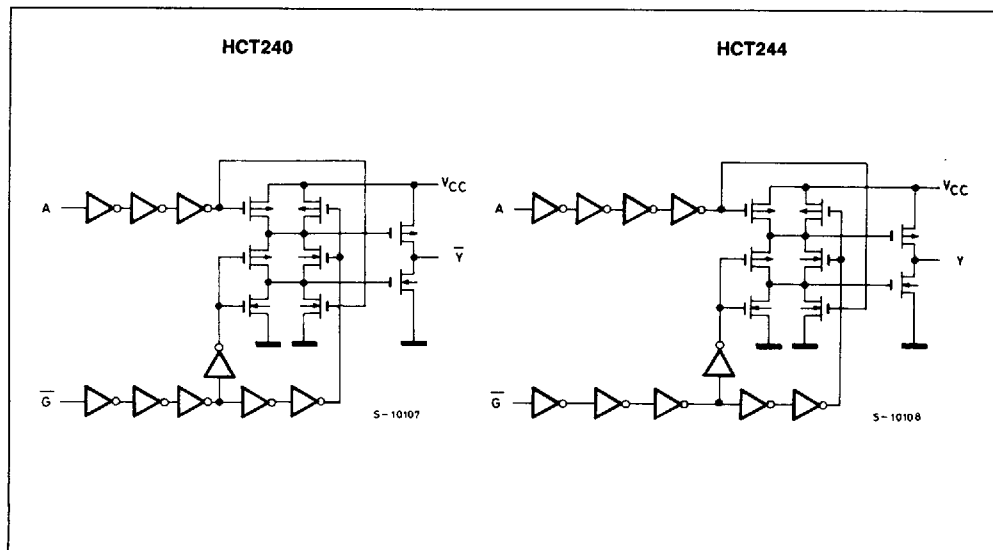

SWITCHING CHARACTERISTICS TEST WAVEFORM

S G S-THOMSON

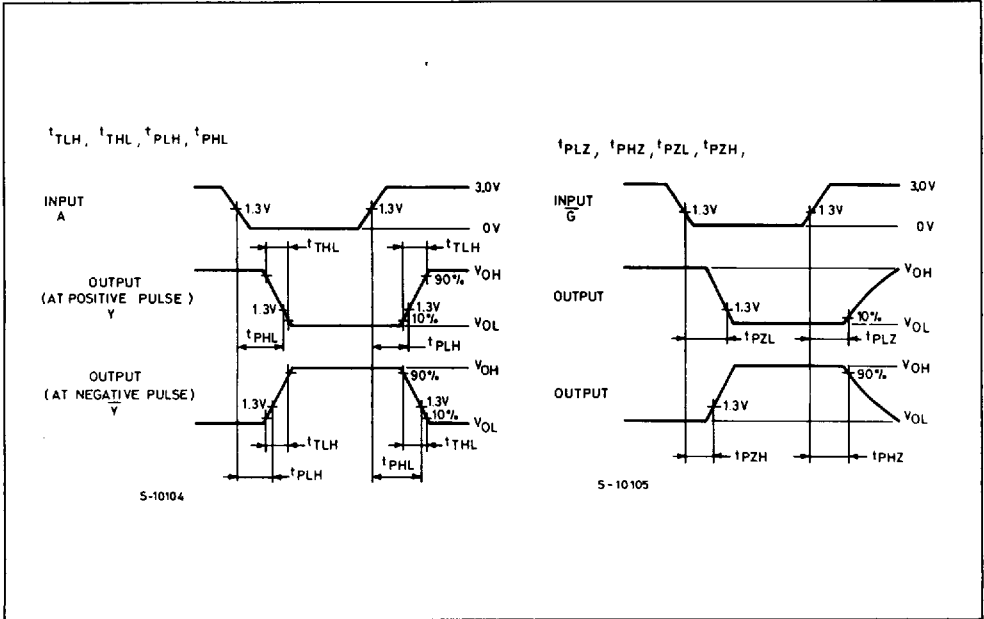

TEST CIRCUIT I_{CC} (Opr.)

