

16-to-8 Multiplexer/Demultiplexer Bus Switch

Features:

- Near-Zero propagation delay
- Low noise, 25-ohm version (PI5C32390)
- 5-ohm switches connect inputs to outputs (PI5C3390)
- Direct bus connection when switches are ON
- Ultra-low quiescent power (0.2μA typical)
– Ideally suited for notebook applications
- Packaging (Pb-free & Green available):
— 28-pin 150-mil wide plastic QSOP (Q)
— 28-pin 300-mil wide plastic SOIC (S)

Description:

Pericom Semiconductor’s PI5C3390 and PI5C32390 are 16-to-8 multiplexer/demultiplexer bus switches with a low On-Resistance allowing inputs to be connected directly to outputs. The two enable inputs connect each of eight I/O to the common I/O pin. This multiplexer function can be used to select and route logic signals to form crossbar switches, isolate bus capacitance, or provide a zero delay switch connection. The bus switch creates no additional ground bounce noise or additional propagation delay. The PI5C32390 is designed with an internal 25-ohm resistor reducing noise reflection in high-speed applications.

Block Diagram

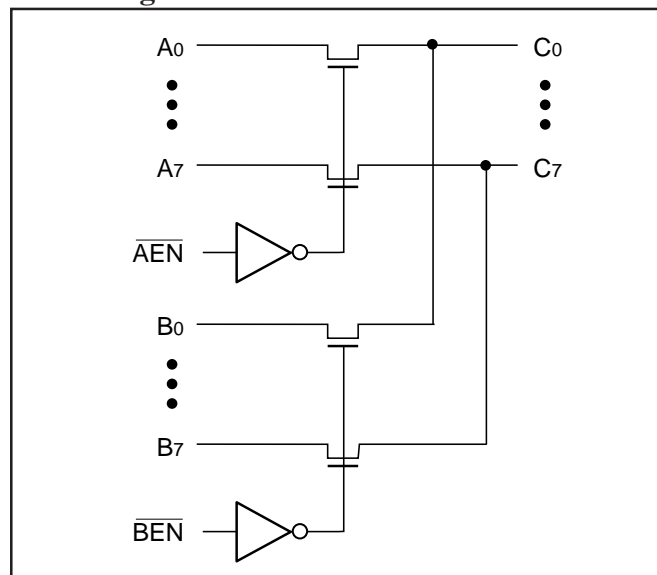

Pin Configuration

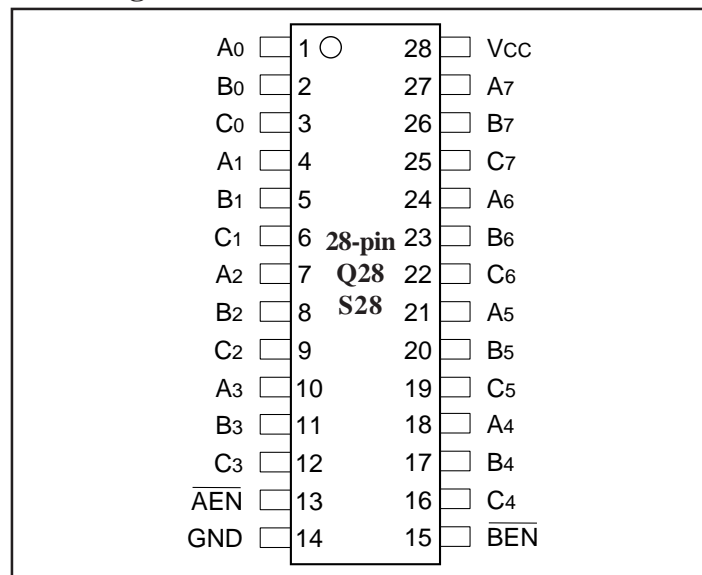

Truth Table⁽¹⁾

| AEN | BEN | ASw | BSw | Function |
|-----|-----|-----|-----|------------|
| H | H | Off | Off | Disconnect |
| L | H | On | Off | A to C |
| H | L | Off | On | B to C |
| L | L | On | On | A, B to C |

Pin Description

| Pin Name | I/O | Description |
|----------|-----|--------------------------------|
| AEN, BEN | I | Bus Output Enable (Active LOW) |
| A0-A7 | I/O | Bus A |
| B0-B7 | I/O | Bus B |
| C0-C7 | I/O | Bus C |

Note:

1. H = High Voltage Level
L = Low Voltage Level

Maximum Ratings

(Above which the useful life may be impaired. For user guidelines, not tested.)

| | |
|--|-----------------|
| Storage Temperature | -65°C to +150°C |
| Ambient Temperature with Power Applied | -40°C to +85°C |
| Supply Voltage to Ground Potential (Inputs & V _{CC} Only) | -0.5V to +7.0V |
| Supply Voltage to Ground Potential (Outputs & D/O Only) | -0.5V to +7.0V |
| DC Input Voltage | -0.5V to +7.0V |
| DC Output Current | 120 mA |
| Power Dissipation | 0.5W |

Note:

Stresses greater than those listed under MAXIMUM RATINGS may cause permanent damage to the device. This is a stress rating only and functional operation of the device at these or any other conditions above those indicated in the operational sections of this specification is not implied. Exposure to absolute maximum rating conditions for extended periods may affect reliability.

DC Electrical Characteristics (Over the Operating Range, T_A = -40°C to +85°C, V_{CC} = 5V ±5%)

| Parameters | Description | Test Conditions ⁽¹⁾ | Min. | Typ ⁽²⁾ | Max. | Units | |
|------------------|--------------------------------------|--|-----------------------|--------------------|----------|----------|-----|
| V _{IH} | Input HIGH Voltage | Guaranteed Logic HIGH Level | 2.0 | | | V | |
| V _{IL} | Input LOW Voltage | Guaranteed Logic LOW Level | -0.5 | | 0.8 | V | |
| I _{IH} | Input HIGH Current | V _{CC} = Max., V _{IN} = V _{CC} | | | ±1 | μA | |
| I _{IL} | Input LOW Current | V _{CC} = Max., V _{IN} = GND | | | ±1 | μA | |
| I _{OZH} | High Impedance Output Current | 0 ≤ A, B, C ≤ V _{CC} | | | ±1 | μA | |
| V _{IK} | Clamp Diode Voltage | V _{CC} = Min., I _{IN} = -18 mA | | -0.7 | -1.2 | V | |
| I _{OS} | Short Circuit Current ⁽³⁾ | A, B (C) = 0V, c (A, B) = V _{CC} | 80 | | | mA | |
| V _H | Input Hysteresis at Control Pins | | | 150 | | mV | |
| R _{ON} | Switch On Resistance ⁽⁴⁾ | V _{CC} = Min., V _{IN} = 0.0V, I _{ON} = 48 mA | PI5C3390 PI5C32390 | — 20 | 5 28 | 7 40 | ohm |
| | | V _{CC} = Min., V _{IN} = 2.4V, I _{ON} = 15 mA | PI5C3390 PI5C32390 | — 20 | 10 35 | 15 48 | ohm |

Capacitance (T_A = 25°C, f = 1 MHz)

| Parameters ⁽⁵⁾ | Description | Test Conditions | Typ | Units |
|---------------------------|-----------------------------|----------------------|-----|-------|
| C _{IN} | Input Capacitance | V _{IN} = 0V | 6 | pF |
| C _{OFF} | A/B Capacitance, Switch Off | V _{IN} = 0V | 6 | pF |
| C _{ON} | A/B Capacitance, Switch On | V _{IN} = 0V | 16 | pF |

Notes:

- For Max. or Min. conditions, use appropriate value specified under Electrical Characteristics for the applicable device type.
- Typical values are at V_{CC} = 5.0V, T_A = 25°C ambient and maximum loading.
- Not more than one output should be shorted at one time. Duration of the test should not exceed one second.
- Measured by the voltage drop between A, B, and C pins at indicated current through the switch. On-Resistance is determined by the lower of the voltages on the two (A,B,C) pins.
- This parameter is determined by device characterization but is not production tested.

Power Supply Characteristics

| Parameters | Description | Test Conditions ⁽¹⁾ | | Min. | Typ ⁽²⁾ | Max. | Units |
|------------------|---|---|--|------|--------------------|------|------------|
| I _{CC} | Quiescent Power Supply Current | V _{CC} =Max. | V _{IN} = GND or V _{CC} | | 0.2 | 30 | μA |
| ΔI _{CC} | Supply Current per Input @ TTL HIGH | V _{CC} =Max. | V _{IN} = 3.4V ⁽³⁾ | | | 3.5 | mA |
| I _{CCD} | Supply Current per Input per MHz ⁽⁴⁾ | V _{CC} =Max., A, B, and C Pins Open \overline{BE} =GND Control Input Toggling 50% Duty Cycle | | | | 0.25 | mA/ MHz |

Notes:

- For Max. or Min. conditions, use appropriate value specified under Electrical Characteristics for the applicable device.
- Typical values are at V_{CC} = 5.0V, +25°C ambient.
- Per TTL driven input (V_{IN} = 3.4V, control inputs only); A, B, and C pins do not contribute to I_{CC}.
- This current applies to the control inputs only and represent the current required to switch internal capacitance at the specified frequency. The A, B, and C inputs generate no significant AC or DC currents as they transition. This parameter is not tested, but is guaranteed by design.

PI5C3390 Switching Characteristics over Operating Range

| Parameters | Description | Conditions ⁽¹⁾ | PI5C3390 | | | Unit |
|--------------------------------------|--|--|----------|------|------|------|
| | | | Com | | | |
| | | | Min. | Typ. | Max. | |
| t _{PLH} t _{PHL} | Propagation Delay ^(2,3) A, B to/from C | C _L = 50 pF R _L = 500-ohm | | 0.25 | | ns |
| t _{PZH} t _{PZL} | Bus Enable Time AEN/BEN to A, B, C | | 1.5 | | 6.5 | ns |
| t _{PHZ} t _{PLZ} | Bus Disable Time AEN/BEN to A, B, C | | 1.5 | | 5.5 | ns |

PI5C32390 Switching Characteristics over Operating Range

| Parameters | Description | Conditions ⁽¹⁾ | PI5C32390 | | | Unit |
|--------------------------------------|--|--|-----------|------|------|------|
| | | | Com | | | |
| | | | Min. | Typ. | Max. | |
| t _{PLH} t _{PHL} | Propagation Delay ^(2,3) A, B to/from C | C _L = 50 pF R _L = 500-ohm | | 1.25 | | ns |
| t _{PZH} t _{PZL} | Bus Enable Time AEN/BEN to A, B, C | | 1.5 | | 6.5 | ns |
| t _{PHZ} t _{PLZ} | Bus Disable Time AEN/BEN to A, B, C | | 1.5 | | 5.5 | ns |

Notes:

- See test circuit and waveforms.
- This parameter is guaranteed but not tested on Propagation Delays.
- The bus switch contributes no propagational delay other than the RC delay of the On-Resistance of the switch and the load capacitance. The time constant for the switch alone is of the order of 0.25 ns for 50 pF load. Since this time constant is much smaller than the rise/fall times of typical driving signals, it adds very little propagational delay to the system. Propagational delay of the bus switch when used in a system is determined by the driving circuit on the driving side of the switch and its interaction with the load on the driven side.

Test Circuit

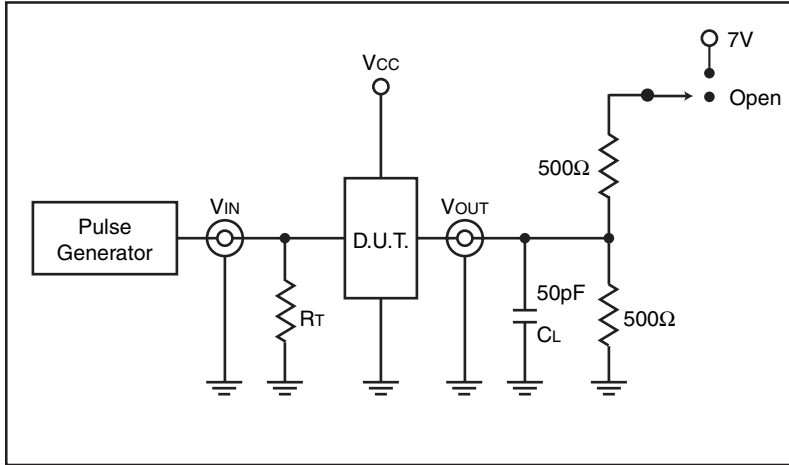

Switch Position

| Test | Switch |
|-------------|--------|
| Disable LOW | Closed |
| Enable LOW | Closed |
| t_{pD} | Open |

Definitions:

C_L = Load capacitance (includes jig and probe capacitance)

R_T = Termination resistance (should be equal to Z_{OUT} of the pulse generator)

Enable and Disable Timing Diagram

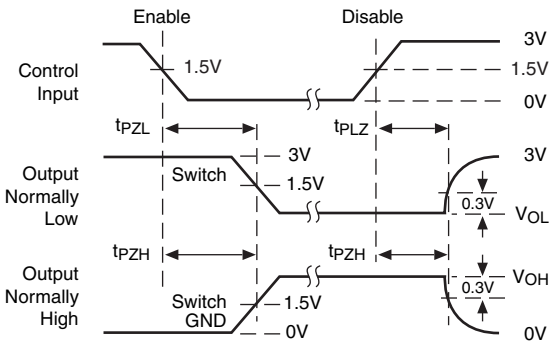

1. Input Control Enable = Low; Input Control Disable = High
2. Pulse Generator for all pulses:
Rate ≤ 1.0 MHz; $Z_{OUT} \leq 50\Omega$; $t_F, t_R \leq 2.5$ ns

Propagation Delay Diagram

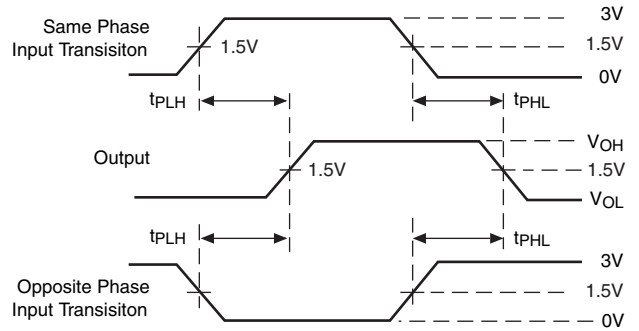

Packaging Mechanical: 28-pin QSOP (Q)

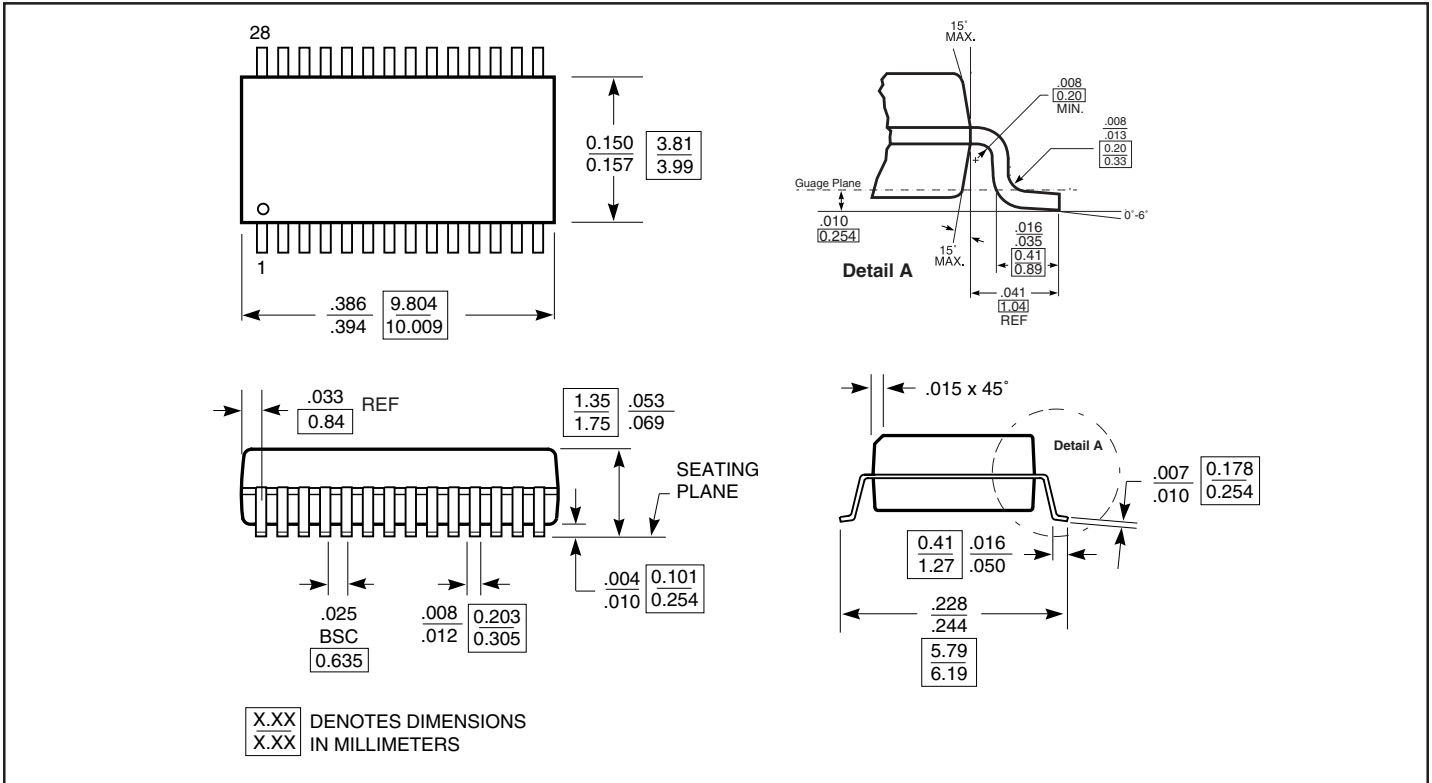

Packaging Mechanical: 28-pin SOIC (S)

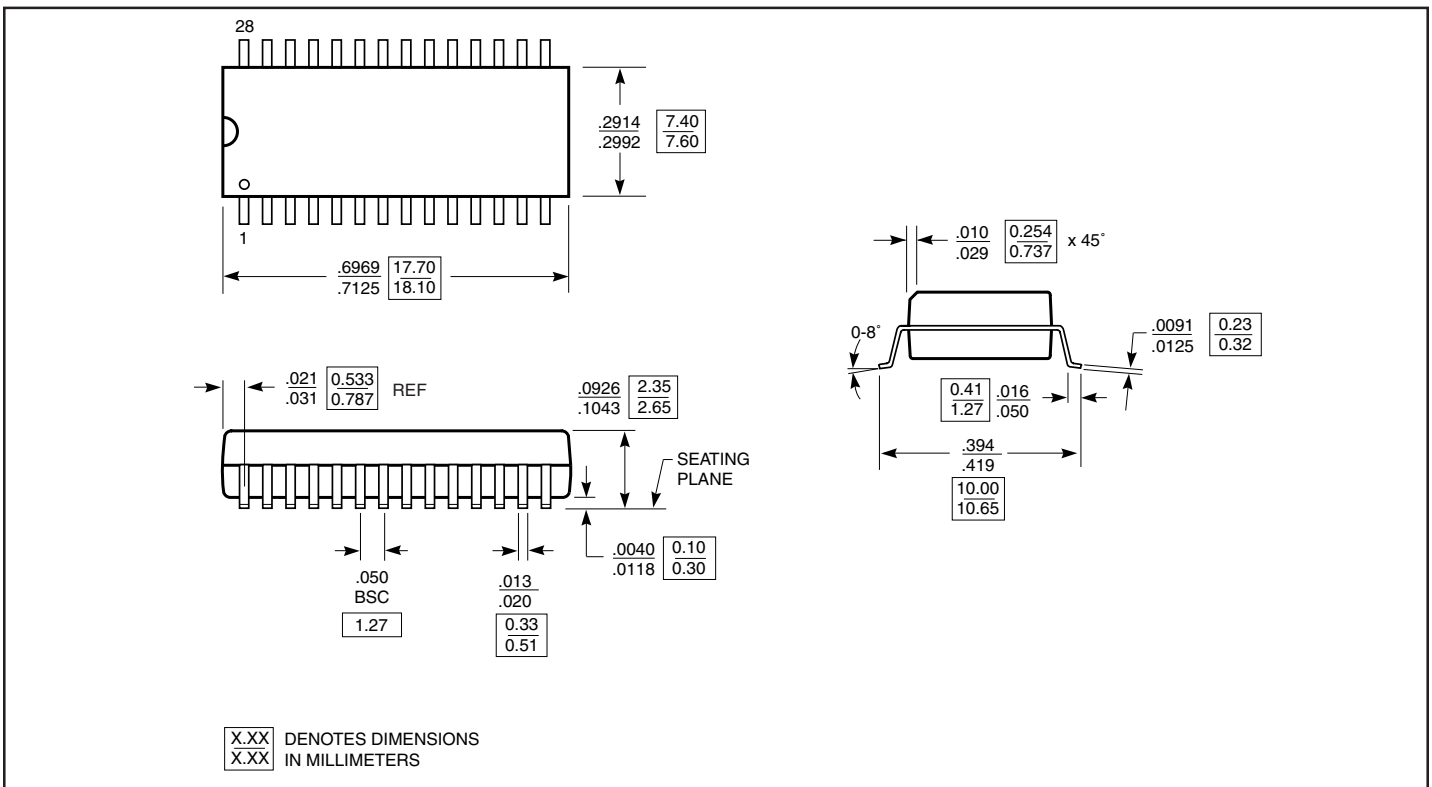

Ordering Information

| Ordering Code | Package Code | Package Description |
|----------------------|---------------------|---|
| PI5C3390Q | Q | 28-pin 150-mil wide plastic QSOP |
| PI5C3390QE | Q | Pb-free & Green, 28-pin 150-mil wide plastic QSOP |
| PI5C3390S | S | 28-pin 300-mil wide plastic SOIC |
| PI5C3390SE | S | Pb-free & Green, 28-pin 300-mil wide plastic SOIC |
| PI5C32390Q | Q | 28-pin 150-mil wide plastic QSOP |
| PI5C32390QE | Q | Pb-free & Green, 28-pin 150-mil wide plastic QSOP |
| PI5C32390S | S | 28-pin 300-mil wide plastic SOIC |
| PI5C32390SE | S | Pb-free & Green, 28-pin 300-mil wide plastic SOIC |

Notes:

- Thermal characteristics can be found on the company web site at www.pericom.com/packaging/
- E = Pb-free & Green
- X suffix = Tape/Reel