

**QUAD 2-INPUT NAND SCHMITT TRIGGER**

**FEATURES**

- Output capability: standard
- I<sup>CC</sup> category: SSI

**GENERAL DESCRIPTION**

The 74HC/HCT132 are high-speed Si-gate CMOS devices and are pin compatible with low power Schottky TTL (LSSTTL). They are specified in compliance with JEDEC standard no. 7A.

The 74HC/HCT132 contain four 2-input NAND gates which accept standard input signals. They are capable of transforming slowly changing input signals into sharply defined, jitter-free output signals.

The gate switches at different points for positive and negative-going signals. The difference between the positive voltage  $V_{T+}$  and the negative voltage  $V_{T-}$  is defined as the hysteresis voltage  $V_H$ .

SYMBOL	PARAMETER	CONDITIONS	TYPICAL		UNIT
			HC	HCT	
$t_{PHL}/t_{PLH}$	propagation delay nA, nB to nY	$C_L = 15 \text{ pF}$ $V_{CC} = 5 \text{ V}$	11	17	ns
$C_I$	input capacitance		3.5	3.5	pF
$C_{PD}$	power dissipation capacitance per gate	notes 1 and 2	24	20	pF

$GND = 0 \text{ V}; T_{amb} = 25 \text{ }^\circ\text{C}; t_r = t_f = 6 \text{ ns}$

**Notes**

- $C_{PD}$  is used to determine the dynamic power dissipation ( $P_D$  in  $\mu\text{W}$ ):  

$$P_D = C_{PD} \times V_{CC}^2 \times f_i + \sum (C_L \times V_{CC}^2 \times f_o)$$
 where:  
 $f_i$  = input frequency in MHz       $C_L$  = output load capacitance in pF  
 $f_o$  = output frequency in MHz       $V_{CC}$  = supply voltage in V  
 $\sum (C_L \times V_{CC}^2 \times f_o)$  = sum of outputs
- For HC the condition is  $V_I = GND$  to  $V_{CC}$   
 For HCT the condition is  $V_I = GND$  to  $V_{CC} - 1.5 \text{ V}$

**PACKAGE OUTLINES**

14-lead mini-pack; plastic (SO14; SOT108A).  
 16-lead DIL; plastic (SOT38Z).

**PIN DESCRIPTION**

PIN NO.	SYMBOL	NAME AND FUNCTION
1, 4, 9, 12	1A to 4A	data inputs
2, 5, 10, 13	1B to 4B	data inputs
3, 6, 8, 11	1Y to 4Y	data outputs
7	GND	ground (0 V)
14	$V_{CC}$	positive supply voltage

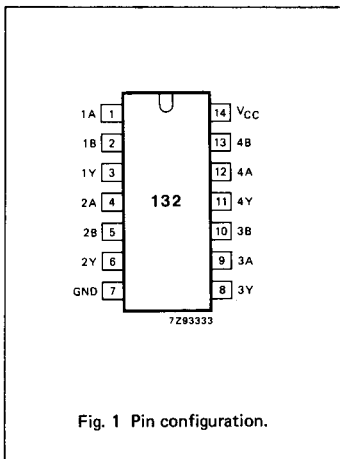

Fig. 1 Pin configuration.

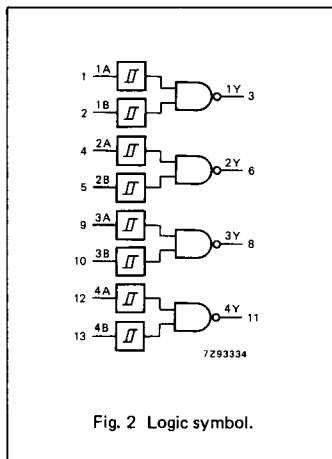

Fig. 2 Logic symbol.

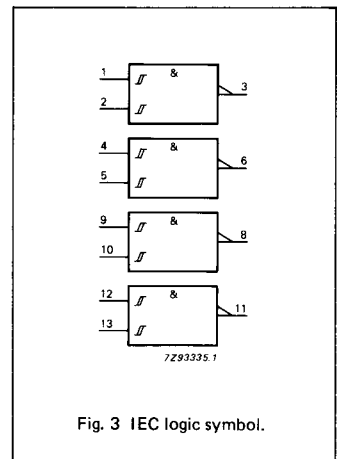

Fig. 3 IEC logic symbol.

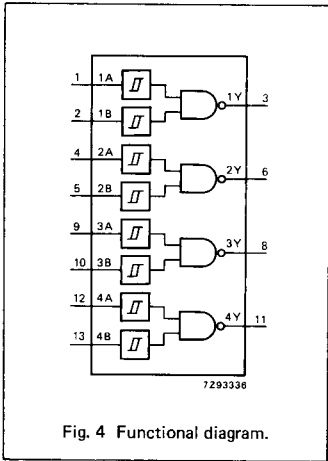

Fig. 4 Functional diagram.

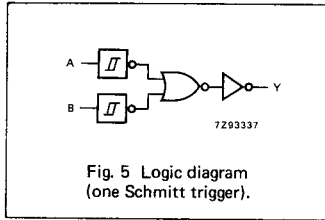

Fig. 5 Logic diagram  
(one Schmitt trigger).

**APPLICATIONS**

- Wave and pulse shapers
- Astable multivibrators
- Monostable multivibrators

**FUNCTION TABLE**

INPUTS		OUTPUT
nA	nB	nY
L	L	H
L	H	H
H	L	H
H	H	L

H = HIGH voltage level  
L = LOW voltage level

**DC CHARACTERISTICS FOR 74HC**

For the DC characteristics see chapter "HCMOS family characteristics", section "Family specifications". Transfer characteristics are given below.

Output capability: standard  
I<sub>CC</sub> category: SSI

**Transfer characteristics for 74HC**

Voltages are referenced to GND (ground = 0 V)

SYMBOL	PARAMETER	T <sub>amb</sub> (°C)								UNIT	TEST CONDITIONS	
		74HC									V <sub>CC</sub> V	WAVEFORMS
		+25			-40 to +85		-40 to +125					
		min.	typ.	max.	min.	max.	min.	max.				
V <sub>T+</sub>	positive-going threshold	0.7 1.7 2.1	1.18 2.38 3.14	1.5 3.15 4.2	0.7 1.7 2.1	1.5 3.15 4.2	0.7 1.7 2.1	1.5 3.15 4.2	V	2.0 4.5 6.0	Figs 6 and 7	
V <sub>T-</sub>	negative-going threshold	0.3 0.9 1.2	0.63 1.67 2.26	1.0 2.2 3.0	0.3 0.9 1.2	1.0 2.2 3.0	0.3 0.9 1.2	1.0 2.2 3.0	V	2.0 4.5 6.0	Figs 6 and 7	
V <sub>H</sub>	hysteresis (V <sub>T+</sub> - V <sub>T-</sub> )	0.2 0.4 0.6	0.55 0.71 0.88	1.0 1.4 1.6	0.2 0.4 0.6	1.0 1.4 1.6	0.2 0.4 0.6	1.0 1.4 1.6	V	2.0 4.5 6.0	Figs 6 and 7	

**AC CHARACTERISTICS FOR 74HC**

GND = 0 V; t<sub>r</sub> = t<sub>f</sub> = 6 ns; C<sub>L</sub> = 50 pF

SYMBOL	PARAMETER	T <sub>amb</sub> (°C)								UNIT	TEST CONDITIONS	
		74HC									V <sub>CC</sub> V	WAVEFORMS
		+25			-40 to +85		-40 to +125					
		min.	typ.	max.	min.	max.	min.	max.				
t <sub>PHL</sub> / t <sub>PLH</sub>	propagation delay nA, nB to nY		36 13 10	125 25 21		155 31 26		190 38 32	ns	2.0 4.5 6.0	Fig. 13	
t <sub>THL</sub> / t <sub>TLH</sub>	output transition time		19 7 6	75 15 13		95 19 16		110 22 19	ns	2.0 4.5 6.0	Fig. 13	

**DC CHARACTERISTICS FOR 74HCT**

For the DC characteristics see chapter "HCMOS family characteristics", section "Family specifications". Transfer characteristics are given below.

Output capability: standard

I<sub>CC</sub> category: SSI

**Note to HCT types**

The value of additional quiescent supply current ( $\Delta I_{CC}$ ) for a unit load of 1 is given in the family specifications. To determine  $\Delta I_{CC}$  per input, multiply this value by the unit load coefficient shown in the table below.

INPUT	UNIT LOAD COEFFICIENT
nA, nB	0.3

**Transfer characteristics for 74HCT**

Voltages are referenced to GND (ground = 0 V)

SYMBOL	PARAMETER	T <sub>amb</sub> (°C)								UNIT	TEST CONDITIONS	
		74HCT									V <sub>CC</sub> V	WAVEFORMS
		+25			-40 to +85		-40 to +125					
		min.	typ.	max.	min.	max.	min.	max.				
V <sub>T+</sub>	positive-going threshold	1.2 1.4	1.41 1.59	1.9 2.1	1.2 1.4	1.9 2.1	1.2 1.4	1.9 2.1	V	4.5 5.5	Figs 6 and 7	
V <sub>T-</sub>	negative-going threshold	0.5 0.6	0.85 0.99	1.2 1.4	0.5 0.6	1.2 1.4	0.5 0.6	1.2 1.4	V	4.5 5.5	Figs 6 and 7	
V <sub>H</sub>	hysteresis (V <sub>T+</sub> - V <sub>T-</sub> )	0.4 0.4	0.56 0.60	—	0.4 0.4	—	0.4 0.4	—	V	4.5 5.5	Figs 6 and 7	

**AC CHARACTERISTICS FOR 74HCT**

GND = 0 V; t<sub>r</sub> = t<sub>f</sub> = 6 ns; C<sub>L</sub> = 50 pF

SYMBOL	PARAMETER	T <sub>amb</sub> (°C)								UNIT	TEST CONDITIONS	
		74HCT									V <sub>CC</sub> V	WAVEFORMS
		+25			-40 to +85		-40 to +125					
		min.	typ.	max.	min.	max.	min.	max.				
t <sub>PHL</sub> / t <sub>PLH</sub>	propagation delay nA, nB to nY		20	33		41		50	ns	4.5	Fig. 13	
t <sub>THL</sub> / t <sub>TLH</sub>	output transition time		7	15		19		22	ns	4.5	Fig. 13	

TRANSFER CHARACTERISTIC WAVEFORMS

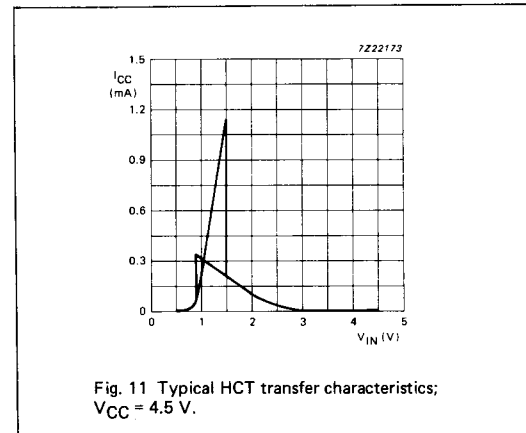
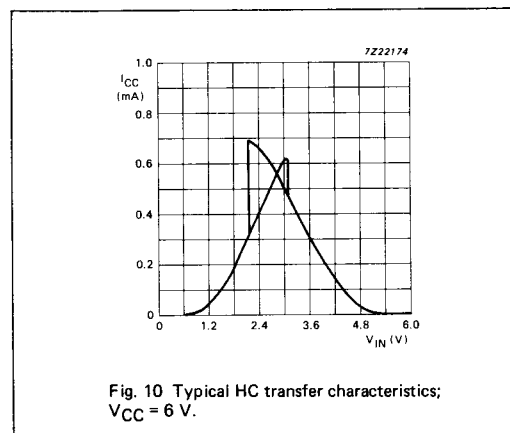
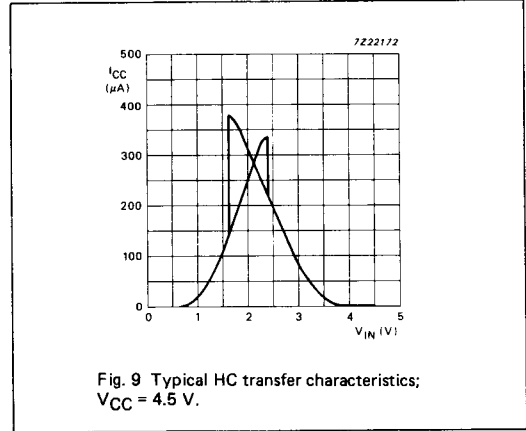
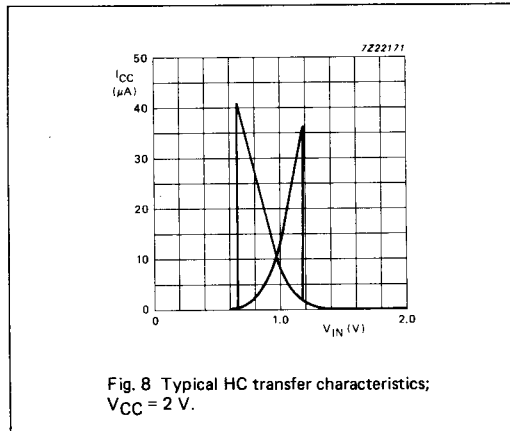
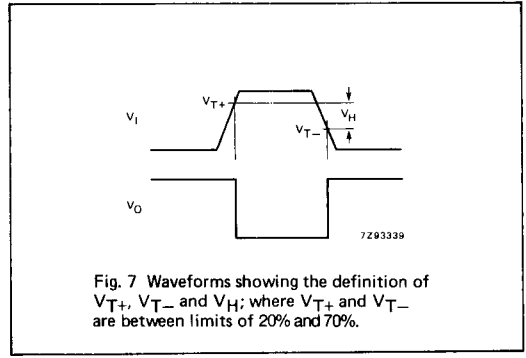
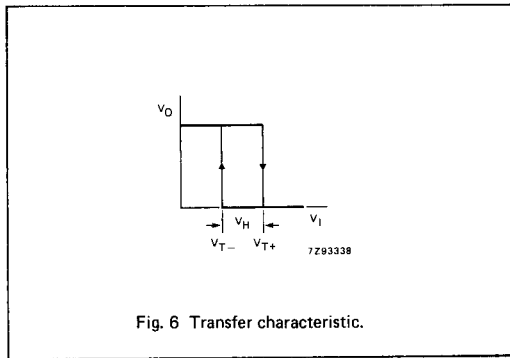

TRANSFER CHARACTERISTIC WAVEFORMS (Cont'd)

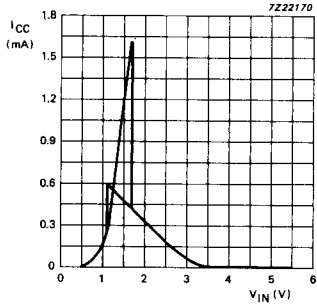

Fig. 12 Typical HCT transfer characteristics;  
 $V_{CC} = 5.5 \text{ V}$ .

AC WAVEFORMS

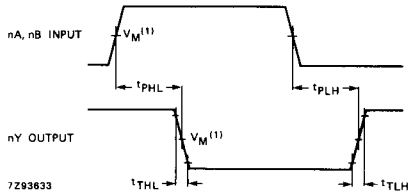

Fig. 13 Waveforms showing the input (nA, nB) to  
output (nY) propagation delays and the output  
transition times.

Note to AC waveforms

- (1) HC :  $V_M = 50\%$ ;  $V_I = \text{GND to } V_{CC}$ .
- HCT:  $V_M = 1.3 \text{ V}$ ;  $V_I = \text{GND to } 3 \text{ V}$ .

**APPLICATION INFORMATION**

The slow input rise and fall times cause additional power dissipation, this can be calculated using the following formula:

$$P_{ad} = f_i \times (t_r \times I_{CCa} + t_f \times I_{CCa}) \times V_{CC}$$

Where:

- $P_{ad}$  = additional power dissipation ( $\mu$ W)
- $f_i$  = input frequency (MHz)
- $t_r$  = input rise time (ns); 10% – 90%
- $t_f$  = input fall time (ns); 10% – 90%
- $I_{CCa}$  = average additional supply current ( $\mu$ A)

Average  $I_{CCa}$  differs with positive or negative input transitions, as shown in Figs 14 and 15.

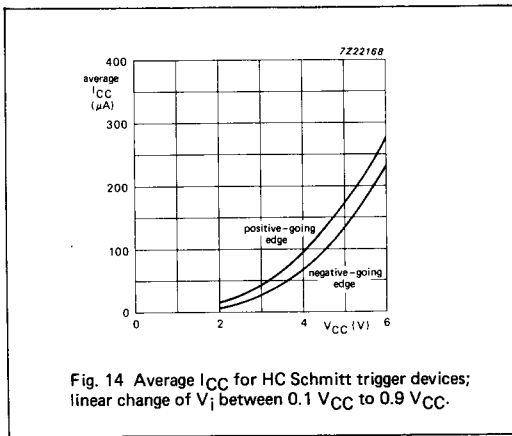

Fig. 14 Average  $I_{CC}$  for HC Schmitt trigger devices; linear change of  $V_i$  between 0.1  $V_{CC}$  to 0.9  $V_{CC}$ .

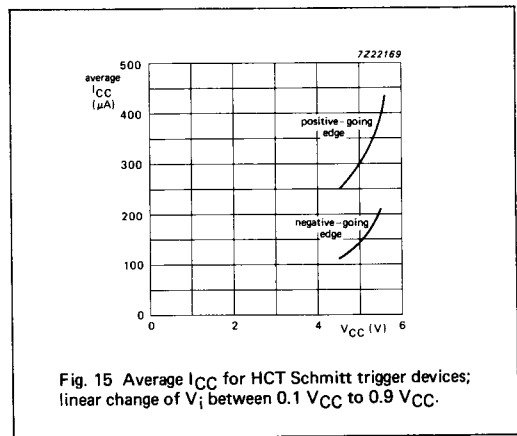

Fig. 15 Average  $I_{CC}$  for HCT Schmitt trigger devices; linear change of  $V_i$  between 0.1  $V_{CC}$  to 0.9  $V_{CC}$ .

HC/HCT132 used in a relaxation oscillator circuit, see Fig. 16.

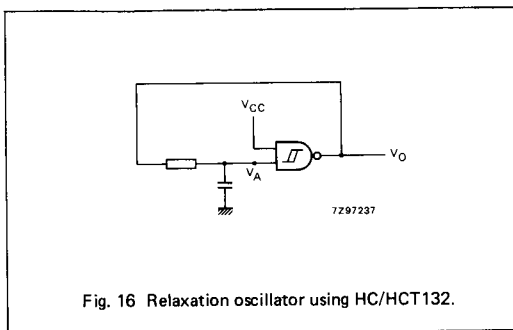

Fig. 16 Relaxation oscillator using HC/HCT132.

Note to Fig. 16

$$HC : f = \frac{1}{T} \approx \frac{1}{0.8 RC}$$

$$HCT : f = \frac{1}{T} \approx \frac{1}{0.67 RC}$$

**Note to Application information**

All values given are typical unless otherwise specified.