

CMOS Hex Buffer/Converters

The Harris CD4049UB and CD4050B are inverting and non-inverting hex buffers, respectively, and feature logic-level conversion using only one supply voltage (V_{CC}). The input-signal high level (V_{IH}) can exceed the V_{CC} supply voltage when these devices are used for logic-level conversions. These devices are intended for use as CMOS to DTL/TTL converters and can drive directly two DTL/TTL loads. ($V_{CC} = 5V$, $V_{OL} \leq 0.4V$, and $I_{OL} \geq 3.3mA$.)

The CD4049UB and CD4050B are designated as replacements for CD4009UB and CD4010B, respectively. Because the CD4049UB and CD4050B require only one power supply, they are preferred over the CD4009UB and CD4010B and should be used in place of the CD4009UB and CD4010B in all inverter, current driver, or logic-level conversion applications. In these applications the CD4049UB and CD4050B are pin compatible with the CD4009UB and CD4010B respectively, and can be substituted for these devices in existing as well as in new designs. Terminal No. 16 is not connected internally on the CD4049UB or CD4050B, therefore, connection to this terminal is of no consequence to circuit operation. For applications not requiring high sink-current or voltage conversion, the CD4069UB Hex Inverter is recommended.

Features

- CD4049UB Inverting
- CD4050B Non-Inverting
- High Sink Current for Driving 2 TTL Loads
- High-To-Low Level Logic Conversion
- 100% Tested for Quiescent Current at 20V
- Maximum Input Current of $1\mu A$ at 18V Over Full Package Temperature Range; $100nA$ at 18V and $25^\circ C$
- 5V, 10V and 15V Parametric Ratings

Applications

- CMOS to DTL/TTL Hex Converter
- CMOS Current "Sink" or "Source" Driver
- CMOS High-To-Low Logic Level Converter

Ordering Information

PART NUMBER	TEMP. RANGE ($^\circ C$)	PACKAGE	PKG. NO.
CD4049UBE	-55 to 125	16 Ld PDIP	E16.3
CD4050BE	-55 to 125	16 Ld PDIP	E16.3
CD4049UBF	-55 to 125	16 Ld CERDIP	F16.3
CD4050BF	-55 to 125	16 Ld CERDIP	F16.3
CD4050BM	-55 to 125	16 Ld SOIC	M16.3

NOTE: Wafer and die for this part number is available which meets all electrical specifications. Please contact your local sales office or Harris customer service for ordering information.

Pinouts

CD4049UB (PDIP, CERDIP)
TOP VIEW

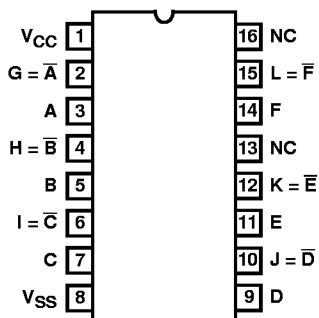

CD4050B (PDIP, CERDIP, SOIC)
TOP VIEW

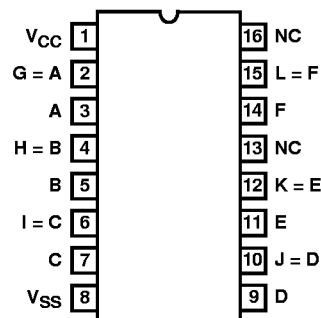

Functional Block Diagrams

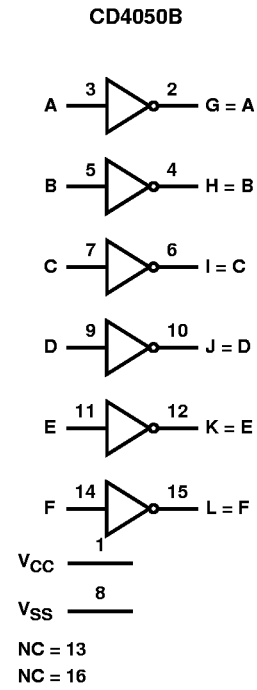
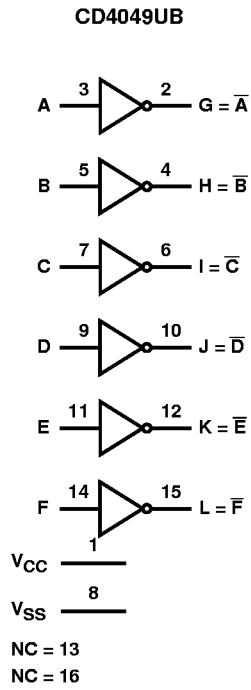

Schematic Diagrams

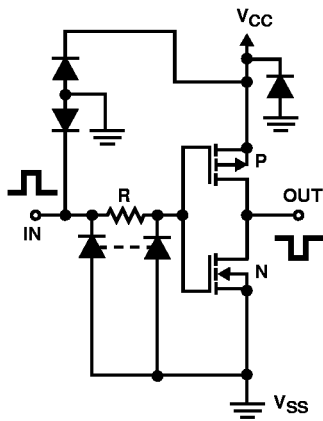

FIGURE 1A. SCHEMATIC DIAGRAM OF CD4049UB, 1 OF 6 IDENTICAL UNITS

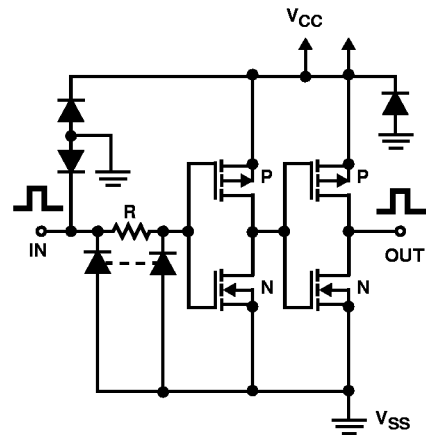

FIGURE 1B. SCHEMATIC DIAGRAM OF CD4050B, 1 OF 6 IDENTICAL UNITS

CD4049UB, CD4050B

Absolute Maximum Ratings

Supply Voltage (V+ to V-)	-0.5V to 20V
DC Input Voltage	-0.5V to V _{DD} +0.5V
DC Input Current, Any One Input	±10mA

Operating Conditions

Temperature Range	-55°C to 125°C
-------------------	----------------

Thermal Information

Thermal Resistance (Typical, Note 1)	θ_{JA} (°C/W)	θ_{JC} (°C/W)
PDIP Package	90	N/A
CERDIP Package	130	55
SOIC Package	100	N/A
Maximum Junction Temperature (Plastic Package)	150°C	
Maximum Storage Temperature Range	-65°C to 150°C	
Maximum Lead Temperature (Soldering 10s)	265°C	
(SOIC - Lead Tips Only)		

CAUTION: Stresses above those listed in "Absolute Maximum Ratings" may cause permanent damage to the device. This is a stress only rating and operation of the device at these or any other conditions above those indicated in the operational sections of this specification is not implied.

NOTE:

- θ_{JA} is measured with the component mounted on an evaluation PC board in free air.

DC Electrical Specifications

PARAMETER	TEST CONDITIONS			LIMITS AT INDICATED TEMPERATURE (°C)							UNITS
				25							
	V _O (V)	V _{IN} (V)	V _{CC} (V)	-55	-40	85	125	MIN	TYP	MAX	
Quiescent Device Current I _{DD} (Max)	-	0,5	5	1	1	30	30	-	0.02	1	μA
	-	0,10	10	2	2	60	60	-	0.02	2	μA
	-	0,15	15	4	4	120	120	-	0.02	4	μA
	-	0,20	20	20	20	600	600	-	0.04	20	μA
Output Low (Sink) Current I _{OL} (Min)	0.4	0,5	4.5	3.3	3.1	2.1	1.8	2.6	5.2	-	mA
	0.4	0,5	5	4	3.8	2.9	2.4	3.2	6.4	-	mA
	0.5	0,10	10	10	9.6	6.6	5.6	8	16	-	mA
	1.5	0,15	15	26	25	20	18	24	48	-	mA
Output High (Source) Current I _{OH} (Min)	4.6	0,5	5	-0.81	-0.73	-0.58	-0.48	-0.65	-1.2	-	mA
	2.5	0,5	5	-2.6	-2.4	-1.9	-1.55	-2.1	-3.9	-	mA
	9.5	0,10	10	-2.0	-1.8	-1.35	-1.18	-1.65	-3.0	-	mA
	13.5	0,15	15	-5.2	-4.8	-3.5	-3.1	-4.3	-8.0	-	mA
Out Voltage Low Level V _{OL} (Max)	-	0,5	5	0.05	0.05	0.05	0.05	-	0	0.05	V
	-	0,10	10	0.05	0.05	0.05	0.05	-	0	0.05	V
	-	0,15	5	0.05	0.05	0.05	0.05	-	0	0.05	V
Output Voltage High Level V _{OH} (Min)	-	0,5	5	4.95	4.95	4.95	4.95	4.95	5	-	V
	-	0,10	10	9.95	9.95	9.95	9.95	9.95	10	-	V
	-	0,15	15	14.95	14.95	14.95	14.95	14.95	15	-	V
Input Low Voltage, V _{IL} (Max) CD4049UB	4.5	-	5	1	1	1	1	-	-	1	V
	9	-	10	2	2	2	2	-	-	2	V
	13.5	-	15	2.5	2.5	2.5	2.5	-	-	2.5	V
Input Low Voltage, V _{IL} (Max) CD4050B	0.5	-	5	1.5	1.5	1.5	1.5	-	-	1.5	V
	1	-	10	3	3	3	3	-	-	3	V
	1.5	-	15	4	4	4	4	-	-	4	V
Input High Voltage, V _{IH} Min CD4049UB	0.5	-	5	4	4	4	4	4	-	-	V
	1	-	10	8	8	8	8	8	-	-	V
	1.5	-	15	12.5	12.5	12.5	12.5	12.5	-	-	V

CD4049UB, CD4050B

DC Electrical Specifications (Continued)

PARAMETER	TEST CONDITIONS			LIMITS AT INDICATED TEMPERATURE (°C)							UNITS
				25							
	V _O (V)	V _{IN} (V)	V _{CC} (V)	-55	-40	85	125	MIN	TYP	MAX	
Input High Voltage, V _{IH} Min CD4050B	4.5	-	5	3.5	3.5	3.5	3.5	3.5	-	-	V
	9	-	10	7	7	7	7	7	-	-	V
	13.5	-	15	11	11	11	11	11	-	-	V
Input Current, I _{IN} Max	-	0,18	18	±0.1	±0.1	±1	±1	-	±10 ⁻⁵	±0.1	μA

AC Electrical Specifications T_A = 25°C, Input t_r, t_f = 20ns, C_L = 50pF, R_L = 200kΩ

PARAMETER	TEST CONDITIONS		LIMITS (ALL PACKAGES)		UNITS
	V _{IN}	V _{CC}	TYP	MAX	
Propagation Delay Time Low to High, t _{PLH} CD4049UB	5	5	60	120	ns
	10	10	32	65	ns
	10	5	45	90	ns
	15	15	25	50	ns
	15	5	45	90	ns
Propagation Delay Time Low to High, t _{PLH} CD4050B	5	5	70	140	ns
	10	10	40	80	ns
	10	5	45	90	ns
	15	15	30	60	ns
	15	5	40	80	ns
Propagation Delay Time High to Low, t _{PHL} CD4049UB	5	5	32	65	ns
	10	10	20	40	ns
	10	5	15	30	ns
	15	15	15	30	ns
	15	5	10	20	ns
Propagation Delay Time High to Low, t _{PHL} CD4050B	5	5	55	110	ns
	10	10	22	55	ns
	10	5	50	100	ns
	15	15	15	30	ns
	15	5	50	100	ns
Transition Time, Low to High, t _{TLH}	5	5	80	160	ns
	10	10	40	80	ns
	15	15	30	60	ns
Transition Time, High to Low, t _{THL}	5	5	30	60	ns
	10	10	20	40	ns
	15	15	15	30	ns
Input Capacitance, C _{IN} CD4049UB	-	-	15	22.5	pF
Input Capacitance, C _{IN} CD4050B	-	-	5	7.5	pF

Typical Performance Curves

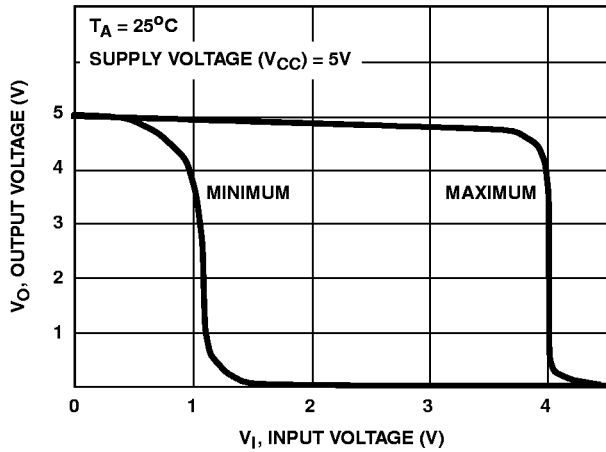

FIGURE 2. MINIMUM AND MAXIMUM VOLTAGE TRANSFER CHARACTERISTICS FOR CD4049UB

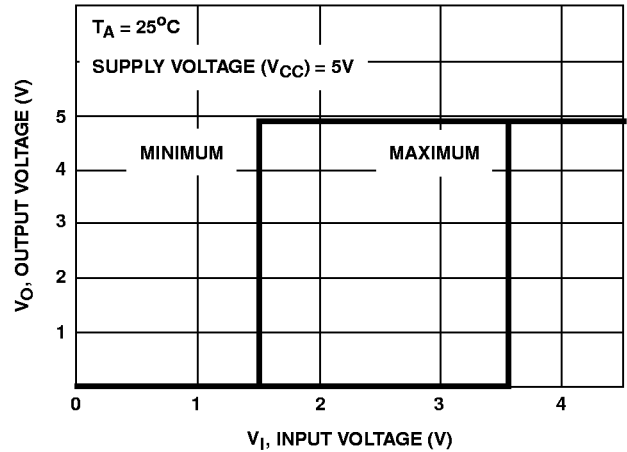

FIGURE 3. MINIMUM AND MAXIMUM VOLTAGE TRANSFER CHARACTERISTICS FOR CD4050B

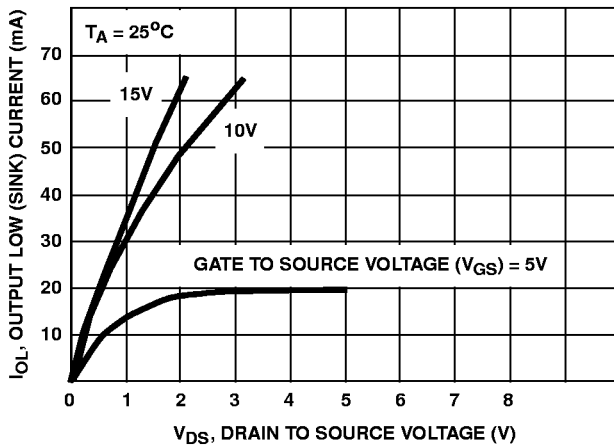

FIGURE 4. TYPICAL OUTPUT LOW (SINK) CURRENT CHARACTERISTICS

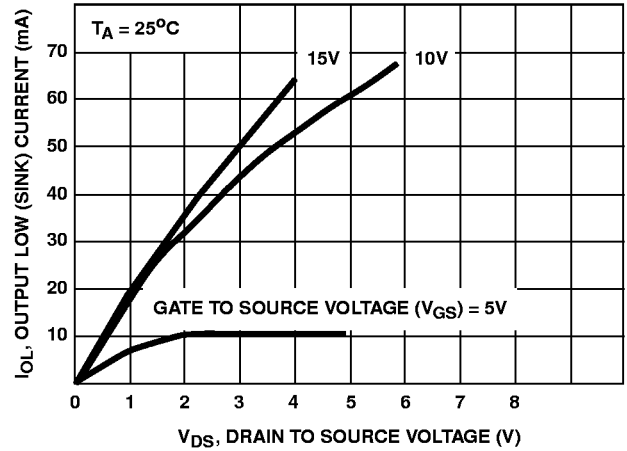

FIGURE 5. MINIMUM OUTPUT LOW (SINK) CURRENT DRAIN CHARACTERISTICS

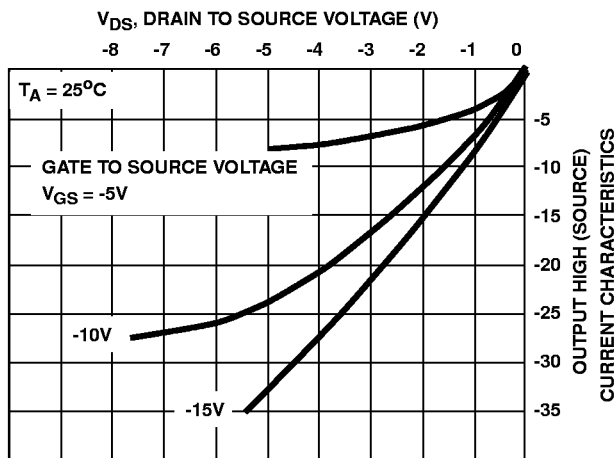

FIGURE 6. TYPICAL OUTPUT HIGH (SOURCE) CURRENT CHARACTERISTICS

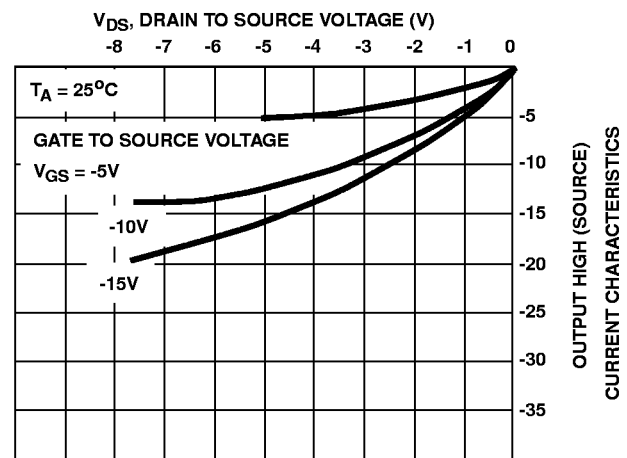

FIGURE 7. MINIMUM OUTPUT HIGH (SOURCE) CURRENT CHARACTERISTICS

Typical Performance Curves (Continued)

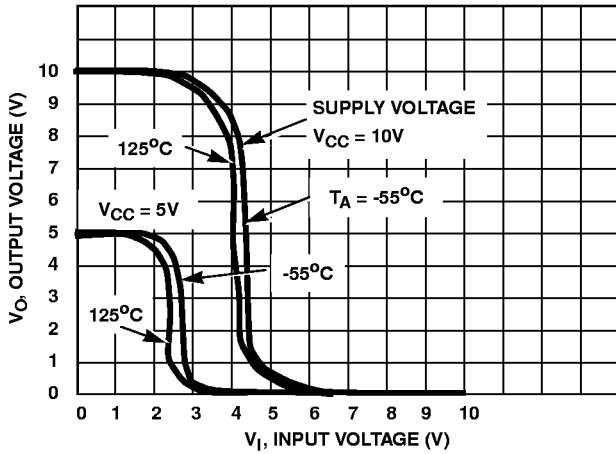

FIGURE 8. TYPICAL VOLTAGE TRANSFER CHARACTERISTICS AS A FUNCTION OF TEMPERATURE FOR CD4049UB

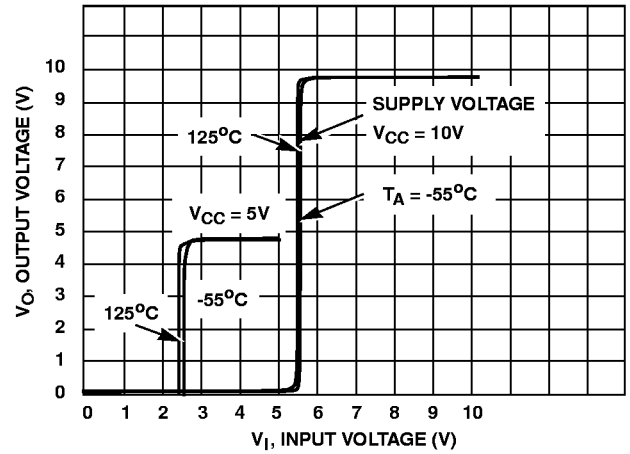

FIGURE 9. TYPICAL VOLTAGE TRANSFER CHARACTERISTICS AS A FUNCTION OF TEMPERATURE FOR CD4050B

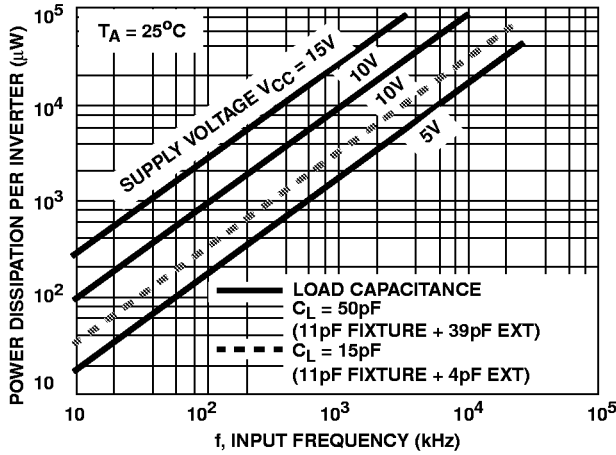

FIGURE 10. TYPICAL POWER DISSIPATION vs FREQUENCY CHARACTERISTICS

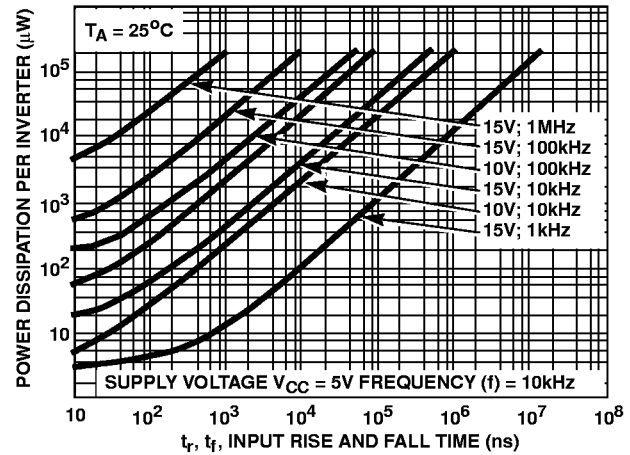

FIGURE 11. TYPICAL POWER DISSIPATION vs INPUT RISE AND FALL TIMES PER INVERTER FOR CD4049UB

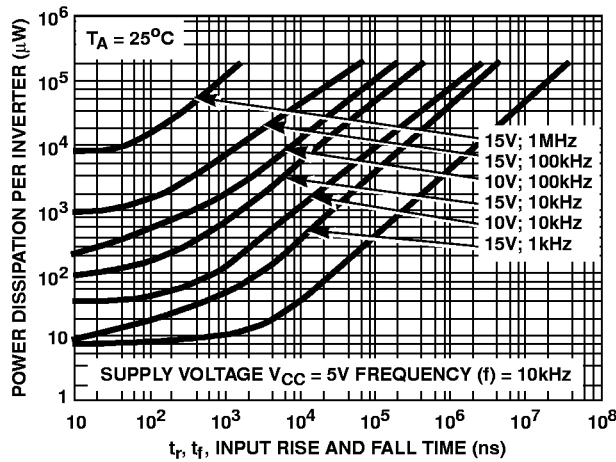

FIGURE 12. TYPICAL POWER DISSIPATION vs INPUT RISE AND FALL TIMES PER INVERTER FOR CD4050B

Test Circuits

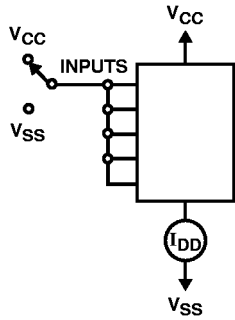
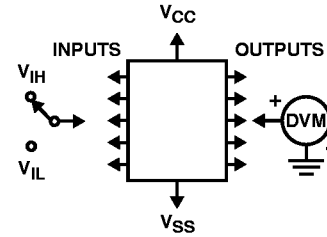
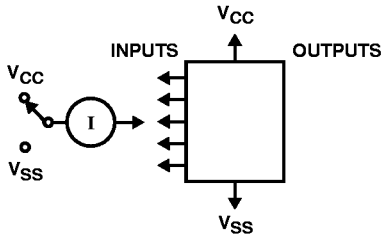

FIGURE 13. QUIESCENT DEVICE CURRENT TEST CIRCUIT



NOTE: Test any one input with other inputs at V_{CC} or V_{SS} .
FIGURE 14. INPUT VOLTAGE TEST CIRCUIT



NOTE: Measure inputs sequentially, to both V_{CC} and V_{SS} connect all unused inputs to either V_{CC} or V_{SS} .

FIGURE 15. INPUT CURRENT TEST CIRCUIT

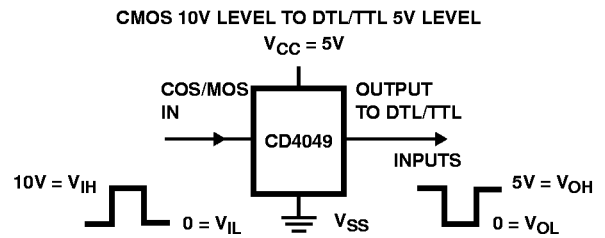

In Terminal - 3, 5, 7, 9, 11, or 14
Out Terminal - 2, 4, 6, 10, 12 or 15
 V_{CC} Terminal - 1
 V_{SS} Terminal - 8

FIGURE 16. LOGIC LEVEL CONVERSION APPLICATION

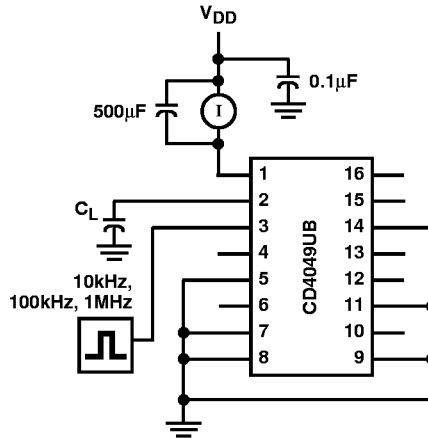

C_L INCLUDES FIXTURE CAPACITANCE

FIGURE 17. DYNAMIC POWER DISSIPATION TEST CIRCUITS

Dual-In-Line Plastic Packages (PDIP)

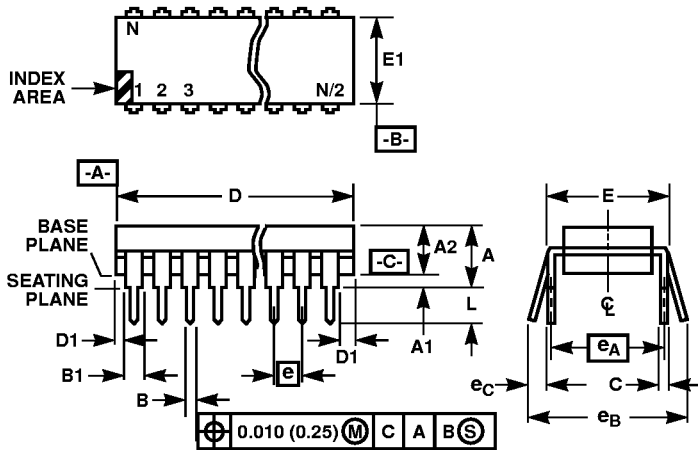

NOTES:

1. Controlling Dimensions: INCH. In case of conflict between English and Metric dimensions, the inch dimensions control.
2. Dimensioning and tolerancing per ANSI Y14.5M-1982.
3. Symbols are defined in the "MO Series Symbol List" in Section 2.2 of Publication No. 95.
4. Dimensions A, A1 and L are measured with the package seated in JEDEC seating plane gauge GS-3.
5. D, D1, and E1 dimensions do not include mold flash or protrusions. Mold flash or protrusions shall not exceed 0.010 inch (0.25mm).
6. E and e_A are measured with the leads constrained to be perpendicular to datum $-C-$.
7. e_B and e_C are measured at the lead tips with the leads unconstrained. e_C must be zero or greater.
8. B1 maximum dimensions do not include dambar protrusions. Dambar protrusions shall not exceed 0.010 inch (0.25mm).
9. N is the maximum number of terminal positions.
10. Corner leads (1, N, N/2 and N/2 + 1) for E8.3, E16.3, E18.3, E28.3, E42.6 will have a B1 dimension of 0.030 - 0.045 inch (0.76 - 1.14mm).

E16.3 (JEDEC MS-001-BB ISSUE D)
16 LEAD DUAL-IN-LINE PLASTIC PACKAGE

SYMBOL	INCHES		MILLIMETERS		NOTES
	MIN	MAX	MIN	MAX	
A	-	0.210	-	5.33	4
A1	0.015	-	0.39	-	4
A2	0.115	0.195	2.93	4.95	-
B	0.014	0.022	0.356	0.558	-
B1	0.045	0.070	1.15	1.77	8, 10
C	0.008	0.014	0.204	0.355	-
D	0.735	0.775	18.66	19.68	5
D1	0.005	-	0.13	-	5
E	0.300	0.325	7.62	8.25	6
E1	0.240	0.280	6.10	7.11	5
e	0.100 BSC		2.54 BSC		-
e_A	0.300 BSC		7.62 BSC		6
e_B	-	0.430	-	10.92	7
L	0.115	0.150	2.93	3.81	4
N	16		16		9

Rev. 0 12/93

Ceramic Dual-In-Line Frit Seal Packages (CERDIP)

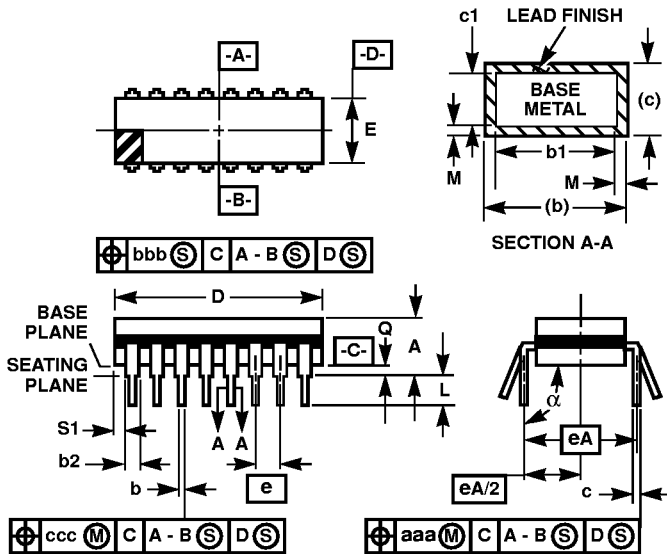

**F16.3 MIL-STD-1835 GDIP1-T16 (D-2, CONFIGURATION A)
16 LEAD CERAMIC DUAL-IN-LINE FRIT SEAL PACKAGE**

SYMBOL	INCHES		MILLIMETERS		NOTES
	MIN	MAX	MIN	MAX	
A	-	0.200	-	5.08	-
b	0.014	0.026	0.36	0.66	2
b1	0.014	0.023	0.36	0.58	3
b2	0.045	0.065	1.14	1.65	-
b3	0.023	0.045	0.58	1.14	4
c	0.008	0.018	0.20	0.46	2
c1	0.008	0.015	0.20	0.38	3
D	-	0.840	-	21.34	5
E	0.220	0.310	5.59	7.87	5
e	0.100 BSC		2.54 BSC		-
eA	0.300 BSC		7.62 BSC		-
eA/2	0.150 BSC		3.81 BSC		-
L	0.125	0.200	3.18	5.08	-
Q	0.015	0.060	0.38	1.52	6
S1	0.005	-	0.13	-	7
alpha	90°	105°	90°	105°	-
aaa	-	0.015	-	0.38	-
bbb	-	0.030	-	0.76	-
ccc	-	0.010	-	0.25	-
M	-	0.0015	-	0.038	2, 3
N	16		16		8

NOTES:

1. Index area: A notch or a pin one identification mark shall be located adjacent to pin one and shall be located within the shaded area shown. The manufacturer's identification shall not be used as a pin one identification mark.
2. The maximum limits of lead dimensions b and c or M shall be measured at the centroid of the finished lead surfaces, when solder dip or tin plate lead finish is applied.
3. Dimensions b1 and c1 apply to lead base metal only. Dimension M applies to lead plating and finish thickness.
4. Corner leads (1, N, N/2, and N/2+1) may be configured with a partial lead paddle. For this configuration dimension b3 replaces dimension b2.
5. This dimension allows for off-center lid, meniscus, and glass overrun.
6. Dimension Q shall be measured from the seating plane to the base plane.
7. Measure dimension S1 at all four corners.
8. N is the maximum number of terminal positions.
9. Dimensioning and tolerancing per ANSI Y14.5M - 1982.
10. Controlling dimension: INCH.

Rev. 0 4/94

Small Outline Plastic Packages (SOIC)

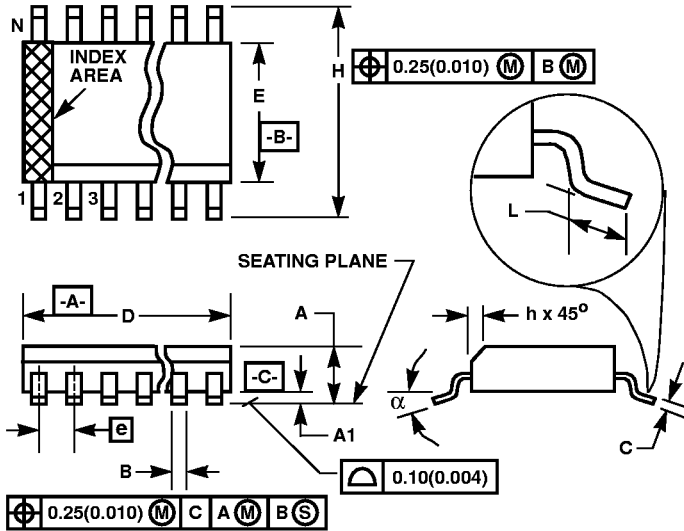

M16.3 (JEDEC MS-013-AA ISSUE C)
16 LEAD WIDE BODY SMALL OUTLINE PLASTIC PACKAGE

SYMBOL	INCHES		MILLIMETERS		NOTES
	MIN	MAX	MIN	MAX	
A	0.0926	0.1043	2.35	2.65	-
A1	0.0040	0.0118	0.10	0.30	-
B	0.013	0.0200	0.33	0.51	9
C	0.0091	0.0125	0.23	0.32	-
D	0.3977	0.4133	10.10	10.50	3
E	0.2914	0.2992	7.40	7.60	4
e	0.050 BSC		1.27 BSC		-
H	0.394	0.419	10.00	10.65	-
h	0.010	0.029	0.25	0.75	5
L	0.016	0.050	0.40	1.27	6
N	16		16		7
α	0°	8°	0°	8°	-

NOTES:

1. Symbols are defined in the "MO Series Symbol List" in Section 2.2 of Publication Number 95.
2. Dimensioning and tolerancing per ANSI Y14.5M-1982.
3. Dimension "D" does not include mold flash, protrusions or gate burrs. Mold flash, protrusion and gate burrs shall not exceed 0.15mm (0.006 inch) per side.
4. Dimension "E" does not include interlead flash or protrusions. Interlead flash and protrusions shall not exceed 0.25mm (0.010 inch) per side.
5. The chamfer on the body is optional. If it is not present, a visual index feature must be located within the crosshatched area.
6. "L" is the length of terminal for soldering to a substrate.
7. "N" is the number of terminal positions.
8. Terminal numbers are shown for reference only.
9. The lead width "B", as measured 0.36mm (0.014 inch) or greater above the seating plane, shall not exceed a maximum value of 0.61mm (0.024 inch)
10. Controlling dimension: MILLIMETER. Converted inch dimensions are not necessarily exact.

Rev. 0 12/93