



54AC/74AC109 • 54ACT/74ACT109

Dual JK Positive Edge-Triggered Flip-Flop

General Description

The 'AC/'ACT109 consists of two high-speed completely independent transition clocked JK flip-flops. The clocking operation is independent of rise and fall times of the clock waveform. The JK design allows operation as a D flip-flop (refer to 'AC/'ACT74 data sheet) by connecting the J and \bar{K} inputs together.

Asynchronous Inputs:

- LOW input to \bar{S}_D (Set) sets Q to HIGH level
- LOW input to \bar{C}_D (Clear) sets Q to LOW level

Clear and Set are independent of clock
 Simultaneous LOW on \bar{C}_D and \bar{S}_D makes both Q and \bar{Q} HIGH

Features

- I_{CC} reduced by 50%
- Outputs source/sink 24 mA
- 'ACT109 has TTL-compatible inputs
- Standard Military Drawing (SMD)
 - 'AC109: 5962-89551
 - 'ACT109: 5962-88534

Ordering Code: See Section 8

Logic Symbols

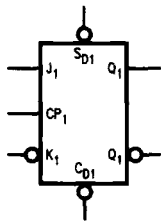

TL/F/9923-1

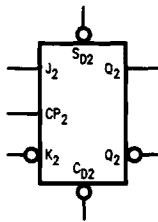

TL/F/9923-2

IEEE/IEC

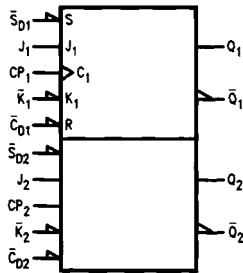

TL/F/9923-7

Pin Names	Description
J ₁ , J ₂ , \bar{K}_1 , \bar{K}_2	Data Inputs
CP ₁ , CP ₂	Clock Pulse Inputs
\bar{C}_D1 , \bar{C}_D2	Direct Clear Inputs
\bar{S}_D1 , \bar{S}_D2	Direct Set Inputs
Q ₁ , Q ₂ , \bar{Q}_1 , \bar{Q}_2	Outputs

Connection Diagrams

Pin Assignment for DIP, Flatpak and SOIC

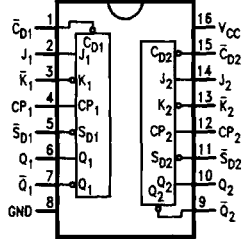

TL/F/9923-3

Pin Assignment for LCC

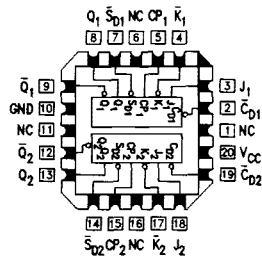

TL/F/9923-4

Truth Table (each half)

Inputs					Outputs	
\bar{S}_D	\bar{C}_D	CP	J	\bar{K}	Q	\bar{Q}
L	H	X	X	X	H	L
H	L	X	X	X	L	H
L	L	X	X	X	H	H
H	H	↗	L	L	L	H
H	H	↗	H	L	Toggle	
H	H	↗	L	H	Q_0	\bar{Q}_0
H	H	↗	H	H	H	L
H	H	L	X	X	Q_0	\bar{Q}_0

H = HIGH Voltage Level
 L = LOW Voltage Level
 ↗ = LOW-to-HIGH Transition
 X = Immaterial
 $Q_0(\bar{Q}_0)$ = Previous $Q_0(\bar{Q}_0)$ before LOW-to-HIGH Transition of Clock

Logic Diagram (one half shown)

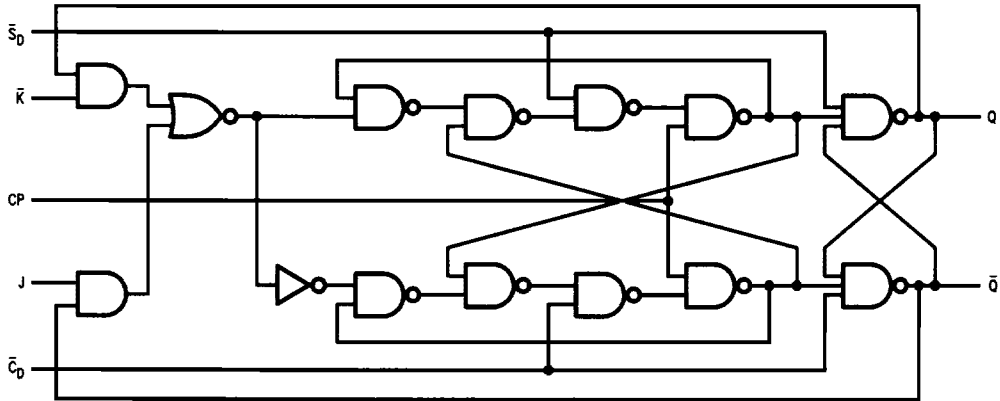

TL/F/9823-5

Please note that this diagram is provided only for the understanding of logic operations and should not be used to estimate propagation delays.

Absolute Maximum Rating (Note 1)

If Military/Aerospace specified devices are required, please contact the National Semiconductor Sales Office/Distributors for availability and specifications.

Supply Voltage (V_{CC})	-0.5V to +7.0V
DC Input Diode Current (I_{IK})	
$V_I = -0.5V$	-20 mA
$V_I = V_{CC} + 0.5V$	+20 mA
DC Input Voltage (V_I)	-0.5V to $V_{CC} + 0.5V$
DC Output Diode Current (I_{OK})	
$V_O = -0.5V$	-20 mA
$V_O = V_{CC} + 0.5V$	+20 mA
DC Output Voltage (V_O)	-0.5V to $V_{CC} + 0.5V$
DC Output Source or Sink Current (I_O)	± 50 mA
DC V_{CC} or Ground Current per Output Pin (I_{CC} or I_{GND})	± 50 mA
Storage Temperature (T_{STG})	-65°C to +150°C
Junction Temperature (T_J)	
CDIP	175°C
PDIP	140°C

Note 1: Absolute maximum ratings are those values beyond which damage to the device may occur. The databook specifications should be met, without exception, to ensure that the system design is reliable over its power supply, temperature, and output/input loading variables. National does not recommend operation of FACT™ circuits outside databook specifications.

Recommended Operating Conditions

Supply Voltage (V_{CC})	
'AC	2.0V to 6.0V
'ACT	4.5V to 5.5V
Input Voltage (V_I)	0V to V_{CC}
Output Voltage (V_O)	0V to V_{CC}
Operating Temperature (T_A)	
74AC/ACT	-40°C to +85°C
54AC/ACT	-55°C to +125°C
Minimum Input Edge Rate ($\Delta V/\Delta t$)	
'AC Devices	
V_{IN} from 30% to 70% of V_{CC}	
V_{CC} @ 3.3V, 4.5V, 5.5V	125 mV/ns
Minimum Input Edge Rate ($\Delta V/\Delta t$)	
'ACT Devices	
V_{IN} from 0.8V to 2.0V	
V_{CC} @ 4.5V, 5.5V	125 mV/ns

DC Characteristics for 'AC Family Devices

Symbol	Parameter	V_{CC} (V)	74AC		54AC	74AC	Units	Conditions		
			$T_A = +25^\circ\text{C}$		$T_A = -55^\circ\text{C to } +125^\circ\text{C}$	$T_A = -40^\circ\text{C to } +85^\circ\text{C}$				
			Typ	Guaranteed Limits						
V_{IH}	Minimum High Level Input Voltage	3.0	1.5	2.1	2.1	2.1	V	$V_{OUT} = 0.1V$ or $V_{CC} - 0.1V$		
		4.5	2.25	3.15	3.15	3.15				
		5.5	2.75	3.85	3.85	3.85				
V_{IL}	Maximum Low Level Input Voltage	3.0	1.5	0.9	0.9	0.9	V	$V_{OUT} = 0.1V$ or $V_{CC} - 0.1V$		
		4.5	2.25	1.35	1.35	1.35				
		5.5	2.75	1.65	1.65	1.65				
V_{OH}	Minimum High Level Output Voltage	3.0	2.99	2.9	2.9	2.9	V	$I_{OUT} = -50 \mu\text{A}$		
		4.5	4.49	4.4	4.4	4.4				
		5.5	5.49	5.4	5.4	5.4				
V_{OL}	Maximum Low Level Output Voltage	3.0		2.56	2.4	2.46	V	* $V_{IN} = V_{IL}$ or V_{IH} -12 mA		
		4.5		3.86	3.7	3.76				
		5.5		4.86	4.7	4.76				
		3.0	0.002	0.1	0.1	0.1			V	$I_{OUT} = 50 \mu\text{A}$
		4.5	0.001	0.1	0.1	0.1				
		5.5	0.001	0.1	0.1	0.1				
I_{IN}	Maximum Input Leakage Current	3.0		0.36	0.5	0.44	V	* $V_{IN} = V_{IL}$ or V_{IH} 12 mA		
		4.5		0.36	0.5	0.44				
		5.5		0.36	0.5	0.44				
I_{IN}	Maximum Input Leakage Current	5.5		± 0.1	± 1.0	± 1.0	μA	$V_I = V_{CC}, \text{GND}$		

*All outputs loaded; thresholds on input associated with output under test.

DC Characteristics for 'AC Family Devices (Continued)

Symbol	Parameter	V _{CC} (V)	74AC		54AC	74AC	Units	Conditions
			T _A = +25°C		T _A = -55°C to +125°C	T _A = -40°C to +85°C		
			Typ	Guaranteed Limits				
I _{OLD}	†Minimum Dynamic Output Current	5.5			50	75	mA	V _{OLD} = 1.65V Max
I _{OHD}		5.5			-50	-75	mA	V _{OHD} = 3.85V Min
I _{CC}	Maximum Quiescent Supply Current	5.5		2.0	40.0	20.0	μA	V _{IN} = V _{CC} or GND

†Maximum test duration 2.0 ms, one output loaded at a time.

Note: I_{IN} and I_{CC} @ 3.0V are guaranteed to be less than or equal to the respective limit @ 5.5V V_{CC}.

I_{CC} for 54AC @ 25°C is identical to 74AC @ 25°C.

DC Characteristics for 'ACT Family Devices

Symbol	Parameter	V _{CC} (V)	74ACT		54ACT	74ACT	Units	Conditions
			T _A = +25°C		T _A = -55°C to +125°C	T _A = -40°C to +85°C		
			Typ	Guaranteed Limits				
V _{IH}	Minimum High Level Input Voltage	4.5	1.5	2.0	2.0	2.0	V	V _{OUT} = 0.1V or V _{CC} - 0.1V
		5.5	1.5	2.0	2.0	2.0		
V _{IL}	Maximum Low Level Input Voltage	4.5	1.5	0.8	0.8	0.8	V	V _{OUT} = 0.1V or V _{CC} - 0.1V
		5.5	1.5	0.8	0.8	0.8		
V _{OH}	Minimum High Level Output Voltage	4.5	4.49	4.4	4.4	4.4	V	I _{OUT} = -50 μA
		5.5	5.49	5.4	5.4	5.4		
		4.5		3.86	3.70	3.76	V	*V _{IN} = V _{IL} or V _{IH} I _{OH} = -24 mA
		5.5		4.86	4.70	4.76		
V _{OL}	Maximum Low Level Output Voltage	4.5	0.001	0.1	0.1	0.1	V	I _{OUT} = 50 μA
		5.5	0.001	0.1	0.1	0.1		
		4.5		0.36	0.50	0.44	V	*V _{IN} = V _{IL} or V _{IH} I _{OL} = 24 mA
		5.5		0.36	0.50	0.44		
I _{IN}	Maximum Input Leakage Current	5.5		±0.1	±1.0	±1.0	μA	V _I = V _{CC} , GND
I _{CC} T	Maximum I _{CC} /Input	5.5	0.6		1.6	1.5	mA	V _I = V _{CC} - 2.1V
I _{OLD}	†Minimum Dynamic Output Current	5.5			50	75	mA	V _{OLD} = 1.65V Max
I _{OHD}		5.5			-50	-75	mA	V _{OHD} = 3.85V Min
I _{CC}	Maximum Quiescent Supply Current	5.5		2.0	40.0	20.0	μA	V _{IN} = V _{CC} or GND

*All outputs loaded; thresholds on input associated with output under test.

†Maximum test duration 2.0 ms, one output loaded at a time.

Note: I_{CC} for 54ACT @ 25°C is identical to 74ACT @ 25°C.

AC Electrical Characteristics: See Section 2 for waveforms

Symbol	Parameter	V _{CC} * (V)	74AC			54AC		74AC		Units	Fig. No.
			T _A = +25°C C _L = 50 pF			T _A = -55°C to +125°C C _L = 50 pF		T _A = -40°C to +85°C C _L = 50 pF			
			Min	Typ	Max	Min	Max	Min	Max		
f _{max}	Maximum Clock Frequency	3.3 5.0	125 150	150 175		65 95		100 125	MHz		
t _{PLH}	Propagation Delay CP _n to Q _n or \bar{Q}_n	3.3 5.0	4.0 2.5	8.0 6.0	13.5 10.0	1.0 1.0	17.5 12.0	3.5 2.0	16.0 10.5	ns 2-3, 4	
t _{PHL}	Propagation Delay CP _n to Q _n or \bar{Q}_n	3.3 5.0	3.0 2.0	8.0 6.0	14.0 10.0	1.0 1.0	13.5 10.0	3.0 1.5	14.5 10.5	ns 2-3, 4	
t _{PLH}	Propagation Delay \bar{C}_{Dn} or \bar{S}_{Dn} to Q _n or \bar{Q}_n	3.3 5.0	3.0 2.5	8.0 6.0	12.0 9.0	1.0 1.0	13.0 9.5	2.5 2.0	13.0 10.0	ns 2-3, 4	
t _{PHL}	Propagation Delay \bar{C}_{Dn} or \bar{S}_{Dn} to Q _n or \bar{Q}_n	3.3 5.0	3.0 2.0	10.0 7.5	12.0 9.5	1.0 1.0	14.0 10.5	3.0 2.0	13.5 10.5	ns 2-3, 4	

*Voltage Range 3.3 is 3.3V ± 0.3V
Voltage Range 5.0 is 5.0V ± 0.5V

AC Operating Requirements : See Section 2 for waveforms

Symbol	Parameter	V _{CC} * (V)	74AC		54AC	74AC		Units	Fig. No.
			T _A = +25°C C _L = 50 pF		T _A = -55°C to +125°C C _L = 50 pF	T _A = -40°C to +85°C C _L = 50 pF			
			Typ	Guaranteed Minimum					
t _s	Setup Time, HIGH or LOW J _n or \bar{K}_n to CP _n	3.3 5.0	3.5 2.0	6.5 4.5	8.0 5.5	7.5 5.0		ns 2-7	
t _h	Hold Time, HIGH or LOW J _n or \bar{K}_n to CP _n	3.3 5.0	-1.5 -0.5	0 0.5	0 0.5	0 0.5		ns 2-7	
t _w	Pulse Width \bar{C}_{Dn} or \bar{S}_{Dn}	3.3 5.0	2.0 2.0	7.0 4.5	8.0 5.5	7.5 5.0		ns 2-4	
t _{rec}	Recovery Time \bar{C}_{Dn} or \bar{S}_{Dn} to CP _n	3.3 5.0	-2.5 -1.5	0 0	0.5 0.5	0 0		ns 2-4, 7	

*Voltage Range 3.3 is 3.3V ± 0.3V
Voltage Range 5.0 is 5.0V ± 0.5V

AC Electrical Characteristics: See Section 2 for waveforms

Symbol	Parameter	V _{CC} * (V)	74ACT			54ACT		74ACT		Units	Fig. No.
			T _A = +25°C C _L = 50 pF			T _A = -55°C to +125°C C _L = 50 pF		T _A = -40°C to +85°C C _L = 50 pF			
			Min	Typ	Max	Min	Max	Min	Max		
f _{max}	Maximum Clock Frequency	5.0	145	210		85		125	MHz		
t _{PLH}	Propagation Delay CP _n to Q _n or \bar{Q}_n	5.0	4.0	7.0	11.0	1.0	14.0	3.5	13.0	ns	2-3, 4
t _{PHL}	Propagation Delay CP _n to Q _n or \bar{Q}_n	5.0	3.0	6.0	10.0	1.0	12.0	2.5	11.5	ns	2-3, 4
t _{PLH}	Propagation Delay \bar{C}_{Dn} or \bar{S}_{Dn} to Q _n or \bar{Q}_n	5.0	2.5	5.5	9.5	1.0	11.5	2.0	10.5	ns	2-3, 4
t _{PHL}	Propagation Delay \bar{C}_{Dn} or \bar{S}_{Dn} to Q _n or \bar{Q}_n	5.0	2.5	6.0	10.0	1.0	12.5	2.0	11.5	ns	2-3, 4

*Voltage Range 5.0 is 5.0V ± 0.5V

AC Operating Requirements: See Section 2 for waveforms

Symbol	Parameter	V _{CC} * (V)	74ACT		54ACT		74ACT		Units	Fig. No.
			T _A = +25°C C _L = 50 pF		T _A = -55°C to +125°C C _L = 50 pF		T _A = -40°C to +85°C C _L = 50 pF			
			Typ	Guaranteed Minimum						
t _s	Setup Time, HIGH or LOW J _n or \bar{K}_n to CP _n	5.0	0.5	2.0		2.5		2.5	ns	2-7
t _h	Hold Time, HIGH or LOW J _n or \bar{K}_n to CP _n	5.0	0	2.0		2.0		2.0	ns	2-7
t _w	Pulse Width CP _n or \bar{C}_{Dn} or \bar{S}_{Dn}	5.0	3.0	5.0		7.0		6.0	ns	2-4
t _{rec}	Recovery Time \bar{C}_{Dn} or \bar{S}_{Dn} to CP _n	5.0	-2.5	0		0.5		0	ns	2-4, 7

*Voltage Range 5.0 is 5.0V ± 0.5V

Capacitance

Symbol	Parameter	Typ	Units	Conditions
C _{IN}	Input Capacitance	4.5	pF	V _{CC} = OPEN
C _{PD}	Power Dissipation Capacitance	35.0	pF	V _{CC} = 5.0V