



DDR Phase Lock Loop Clock Driver (60MHz - 210MHz)

Recommended Application:

DDR Clock Driver

Product Description/Features:

- Low skew, low jitter PLL clock driver
- Feedback pins for input to output synchronization
- Spread Spectrum tolerant inputs
- With bypass mode mux
- Operating frequency 60 to 210 MHz
- AC Coupled (Universal) CLK inputs:
 - 400 mV switching amplitude
 - (LVTTTL, LVPELL, LVDS, LVCMOS) standards translation to SSTL2

Switching Characteristics:

- CYCLE - CYCLE jitter: <60ps
- OUTPUT - OUTPUT skew: <60ps
- Period jitter: ± 30 ps
- DUTY CYCLE: 49.5% - 50.5%

Pin Configuration

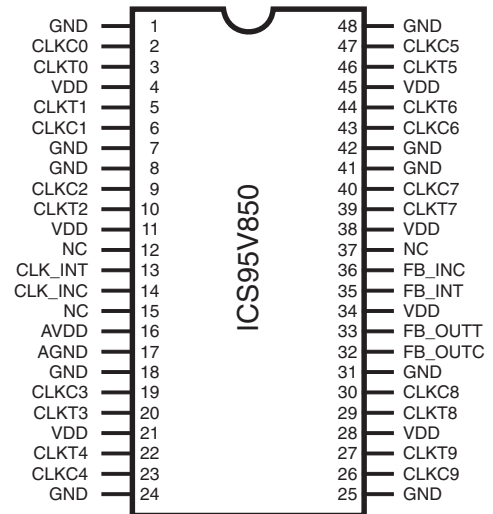

48-Pin TSSOP

6.10mm Body, 0.5mm Pitch

Block Diagram

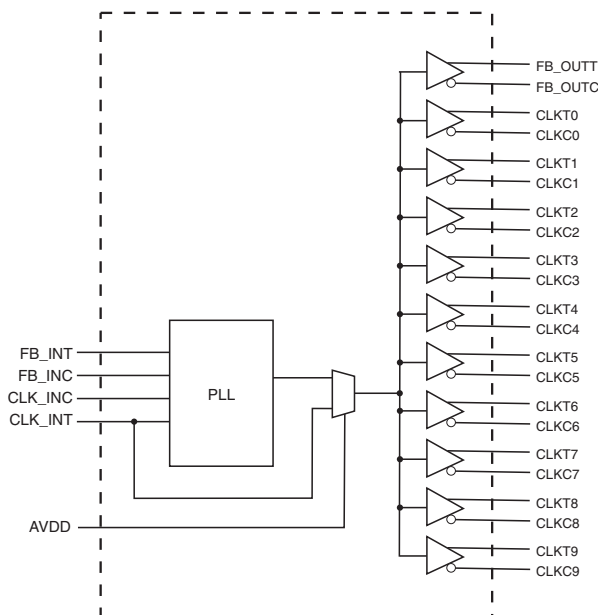

Functionality

AVDD	INPUTS			OUTPUTS			PLL State
	CLK_INT	CLK_INC	CLKT	CLKC	FB_OUTT	FB_OUTC	
GND	L	H	L	H	L	H	Bypassed/Off
GND	H	L	H	L	H	L	Bypassed/Off
2.5V (nom)	L	H	L	H	L	H	On
2.5V (nom)	H	L	H	L	H	L	On



Pin Descriptions

PIN NUMBER	PIN NAME	TYPE	DESCRIPTION
1, 7, 8, 18, 24, 25, 31, 41, 42, 48	GND	PWR	Ground
26, 30, 40, 43, 47, 23, 19, 9, 6, 2	CLK[9:0]	OUT	"Complementary" clocks of differential pair outputs
27, 29, 39, 44, 46, 22, 20, 10, 5, 3	CLK[9:0]	OUT	"True" Clock of differential pair outputs
4, 11, 21, 28, 34, 38, 45,	VDD	PWR	Power supply, 2.5V
13	CLK_INT	IN	"True" reference clock input
14	CLK_INC	IN	"Complementary" reference clock input
16	AVDD	PWR	Analog power supply, 2.5V
17	AGND	PWR	Analog ground
32	FB_OUTC	OUT	"Complementary" Feedback output, dedicated for external feedback. It switches at the same frequency as the CLK. This output must be wired to FB_INC
33	FB_OUTT	OUT	"True" Feedback output, dedicated for external feedback. It switches at the same frequency as the CLK. This output must be wired to FB_INT
35	FB_INT	IN	"True" Feedback input, provides feedback signal to the internal PLL for synchronization with CLK_INT to eliminate phase error
36	FB_INC	IN	"Complementary" Feedback input, provides signal to the internal PLL for synchronization with CLK_INC to eliminate phase error
12, 15, 37	NC		No Connects



Absolute Maximum Ratings

- Supply Voltage: (VDD & AVDD) -0.5V to 3.6V
- Input clamp current: I_{IK} ($V_I < 0$ or $V_I > V_{DD}$) +/- 50mA
- Output clamp current: I_{OK} ($V_O < 0$ or $V_O > V_{DD}$) . . +/- 50mA
- Continuous output current: I_O ($V_O = 0$ to V_{DD}) +/- 50mA
- Package thermal impedance, theta JA: DGG package +89°C/Ω
- Storage Temperature -65°C to +150°C

Stresses above those listed under *Absolute Maximum Ratings* may cause permanent damage to the device. These ratings are stress specifications only and functional operation of the device at these or any other conditions above those listed in the operational sections of the specifications is not implied. Exposure to absolute maximum rating conditions for extended periods may affect product reliability.

Electrical Characteristics - Input/Supply/Common Output Parameters

$T_A = 0 - 85^\circ\text{C}$; Supply Voltage $A_{V_{DD}}$, $V_{DD} = 2.5 \text{ V} \pm 0.2\text{V}$ (unless otherwise stated)

PARAMETER	SYMBOL	CONDITIONS	MIN	TYP	MAX	UNITS
Input High Current	I_{IH}	$V_I = V_{DD}$ or GND	5			μA
Input Low Current	I_{IL}	$V_I = V_{DD}$ or GND			5	μA
Operating Supply Current	$I_{DD2.5}$	$C_L = 0\text{pf}$ @ 200MHz			148	mA
	I_{DDPD}	$C_L = 0\text{pf}$			100	μA
High Impedance Output Current	I_{OZ}	$V_{DD} = 2.7\text{V}$, $V_{out} = V_{DD}$ or GND			±10	mA
Input Clamp Voltage	V_{IK}	$V_{DD} = 2.3\text{V}$ $I_{in} = -18\text{mA}$			-1.2	V
High-level output voltage	V_{OH}	$I_{OH} = -1 \text{ mA}$	$V_{DD} - 0.1$			V
		$I_{OH} = -12 \text{ mA}$	1.7V			V
Low-level output voltage	V_{OL}	$I_{OL} = 1 \text{ mA}$			0.1	V
		$I_{OH} = 12 \text{ mA}$			0.6	V
Input Capacitance ¹	C_{IN}	$V_I = \text{GND}$ or V_{DD}	2.5		3.5	pF

¹Guaranteed by design at 233MHz, not 100% tested in production.



Recommended Operating Condition (see note1)

$T_A = 0 - 85^\circ\text{C}$; Supply Voltage AVDD, VDD = 2.5 V +/- 0.2V (unless otherwise stated)

PARAMETER	SYMBOL	CONDITIONS	MIN	TYP	MAX	UNITS
Supply Voltage	V_{DD}, A_{VDD}		2.3	2.5	2.7	V
Low level input voltage	V_{IL}	CLK_INT, CLK_INC, FB_INC		0.4	$V_{DD}/2 - 0.18$	V
		CLK_INT, CLK_INC (Universal Input)	-0.3		$V_{DD} - 0.4$	V
High level input voltage	V_{IH}	CLK_INT, CLK_INC, FB_INC	$V_{DD}/2 + 0.18$	2.1		V
		CLK_INT, CLK_INC (Universal Input)	0.4		$V_{DD} + 0.3$	V
DC input signal voltage (note 2)	V_{IN}		-0.3		$V_{DD} + 0.3$	V
Differential input signal voltage (note 3)	V_{ID}	DC - CLK_INT, FB_INT	0.36		$V_{DD} + 0.6$	V
		AC - CLK_INT, FB_INT (Universal Input)	0.4		$V_{DD} + 0.6$	V
Output differential cross-voltage (note 4)	V_{OX}		$V_{DD}/2 - 0.15$		$V_{DD}/2 + 0.15$	V
Input differential cross-voltage (note 4)	V_{IX}	(Universal Input)	$0.45(V_{IH} - V_{IL})$		$0.55(V_{IH} - V_{IL})$	V
High level output current	I_{OH}				-6.4	mA
Low level output current	I_{OL}				5.5	mA
Operating free-air temperature	T_A		0		85	$^\circ\text{C}$

Notes:

- Unused inputs must be held high or low to prevent them from floating.
- DC input signal voltage specifies the allowable DC execution of differential input.
- Differential inputs signal voltages specifies the differential voltage [VTR-VCP] required for switching, where VT is the true input level and VCP is the complementary input level.
- Differential cross-point voltage is expected to track variations of V_{DD} and is the voltage at which the differential signal must be crossing.

Timing Requirements

$T_A = 0 - 85^\circ\text{C}$; Supply Voltage AVDD, VDD = 2.5 V +/- 0.2V (unless otherwise stated)

PARAMETER	SYMBOL	CONDITIONS	MIN	TYP	MAX	UNITS
Operating clock frequency	freq_{op}		66		210	MHz
Input clock duty cycle	d_{tin}		40		60	%
CLK stabilization	T_{STAB}				15	μs

**Switching Characteristics (see note 3)**

PARAMETER	SYMBOL	CONDITION	MIN	TYP	MAX	UNITS
Low-to high level propagation delay time	t_{PLH}^1	CLK_IN to any output		5.5		ns
High-to low level propagation delay time	t_{PLL}^1	CLK_IN to any output		5.5		ns
Period jitter	$T_{jit(per)}$	100MHz to 200MHz	-30		30	ps
Half-period jitter	$t(jit_hper)$	100MHz to 200MHz	-75		30	ps
Input clock slew rate	$t_{sl(i)}$		1		4	V/ns
Output clock slew rate	$t_{sl(o)}$		1		2.5	V/ns
Cycle to Cycle Jitter ¹	$T_{cyc}-T_{cyc}$	100MHz to 200MHz			60	ps
Phase error	$t_{(phase\ error)}^4$		-50	0	50	ps
Output to Output Skew	T_{skew}				60	ps

Notes:

1. Refers to transition on noninverting output in PLL bypass mode.
2. While the pulse skew is almost constant over frequency, the duty cycle error increases at higher frequencies. This is due to the formula: duty cycle= t_{WH}/t_c , where the cycle (t_c) decreases as the frequency goes up.
3. Switching characteristics guaranteed for application frequency range.
4. Static phase offset shifted by design.



Parameter Measurement Information

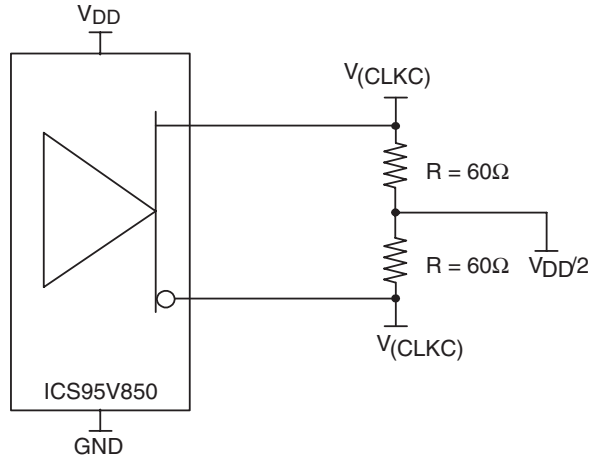
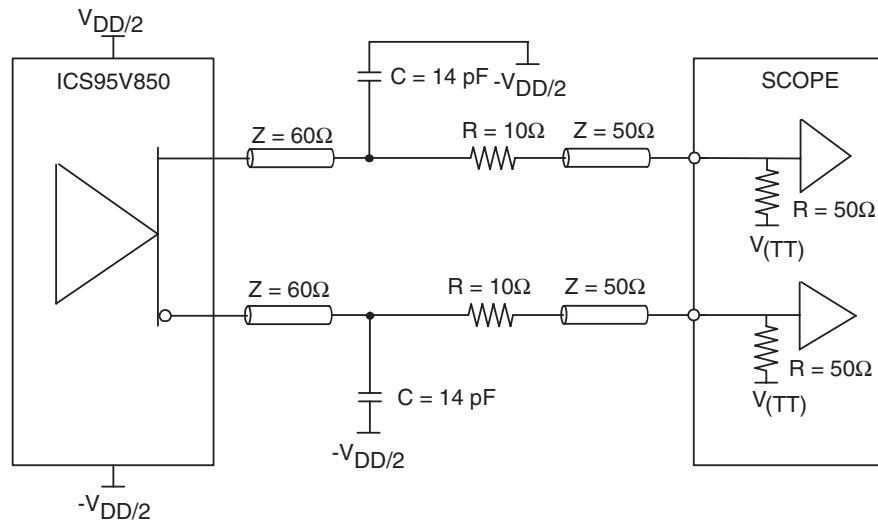

Figure 1. IBIS Model Output Load



NOTE: $V_{(TT)} = \text{GND}$

Figure 2. Output Load Test Circuit

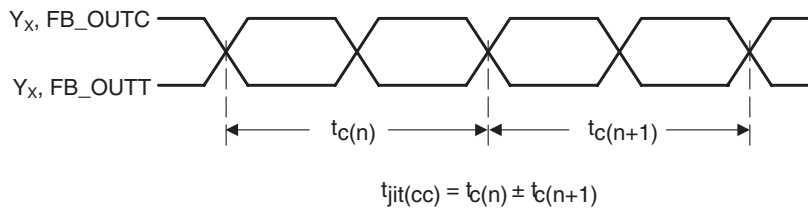

Figure 3. Cycle-to-Cycle Jitter



Parameter Measurement Information

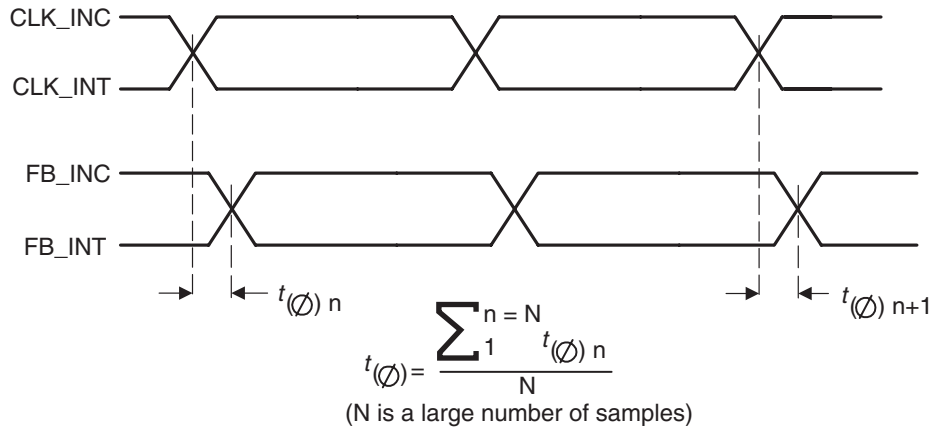

Figure 4. Static Phase Offset

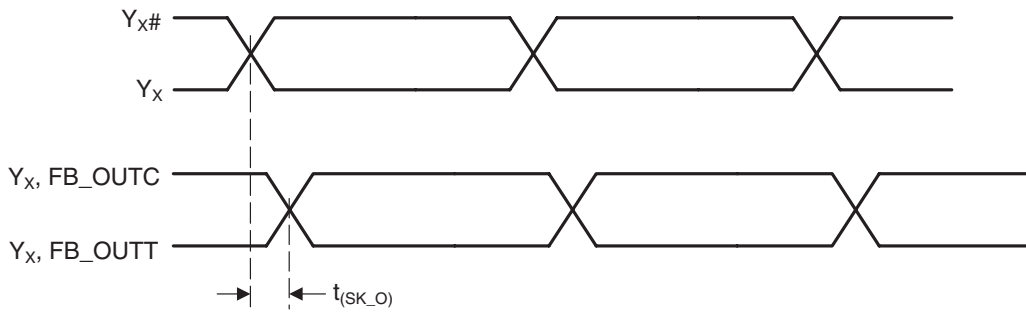

Figure 5. Output Skew

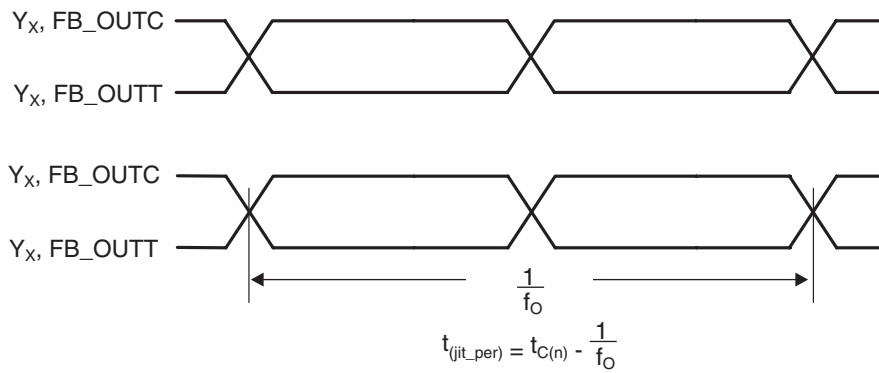

Figure 6. Period Jitter



Parameter Measurement Information

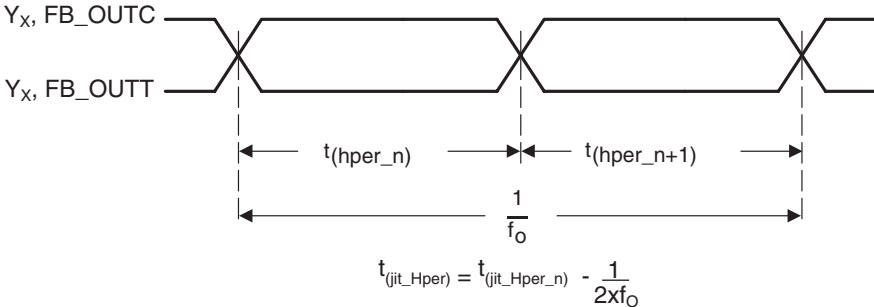

Figure 7. Half-Period Jitter

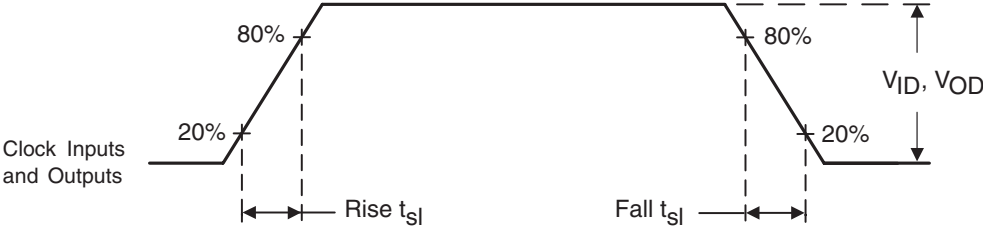

Figure 8. Input and Output Slew Rates



Recommended Layout for the ICS95V850

General Layout Precautions:

Use copper flooded ground on the top signal layer under the clock buffer. The area under U1 on the right is an example. Flood over the ground vias.

- 1) Use power vias for power and ground. Vias 20 mil or larger in diameter have lower high frequency impedance. Vias for signals may be minimum drill size.
- 2) Make all power and ground traces are as wide as the via pad for lower inductance.
- 3) VAA for pin 16 has a low pass RC filter to decouple the digital and analog supplies. The 4.7uF capacitors may be replaced with a single low ESR device with the same total capacitance. VAA is routed on a outside signal layer. Do not cut a power or ground plane and route in it.
- 4) Notice that ground vias are never shared.
- 5) When ever possible, VCC (net V2P5 in the schematic) pins have a decoupling capacitor. Power is always routed from the plane connection via to the capacitor pad to the VCC pin on the clock buffer. Moats or plane cuts are not used to isolate power.
- 6) Differential mode clock output traces are routed:
 - a. With a ground trace between the pairs. Trace is grounded on both ends.
 - b. Without a ground trace, clock pairs are routed with a separation of at least 5 times the thickness of the dielectric. If the dielectric thickness is 4.5 mil, the trace separation is at least 18 mils.
- 7) Terminate differential CLK_IN and FB_IN traces after routing to buffer pads.

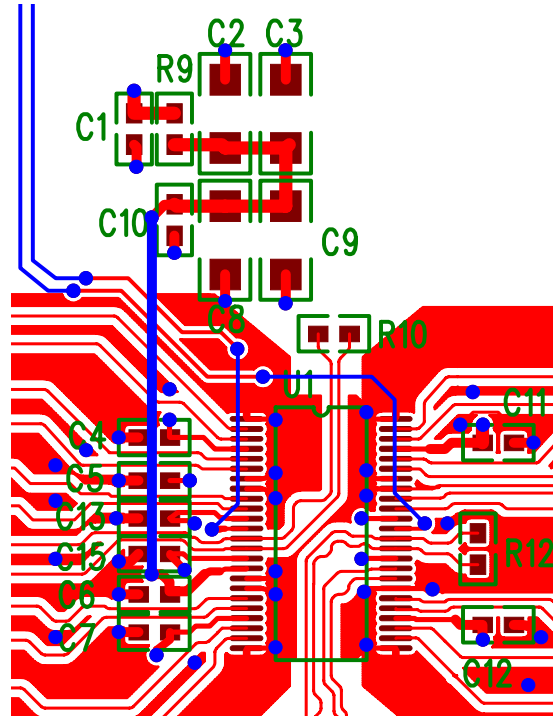

Component Values:

Ref Desg.	Value	Description	Package
C1, C4, C5, C7, C11, C12	.01uF	CERAMIC MLC	0603
C2, C3, C8, C9	4.7uF	CERAMIC MLC	1206
C10	.22uF	CERAMIC MLC	0603
C6	2200pF	CERAMIC MLC	0603
R9, R12	120 Ω		0603
R9	4.7 Ω		0603
U1		ICS95V850	TSSOP48

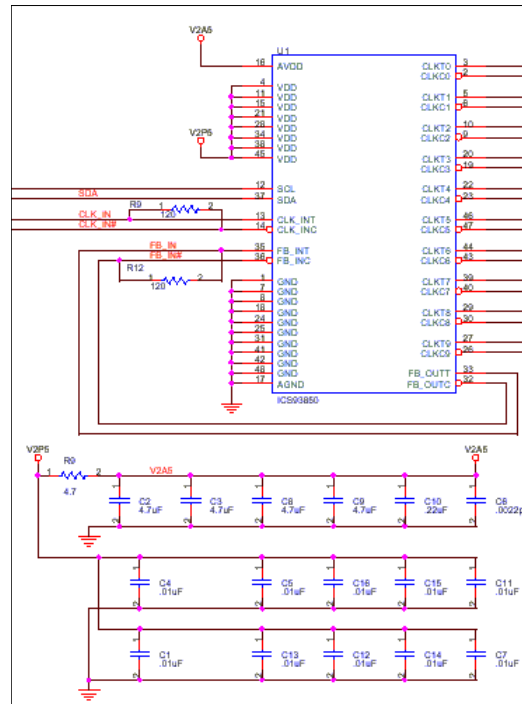

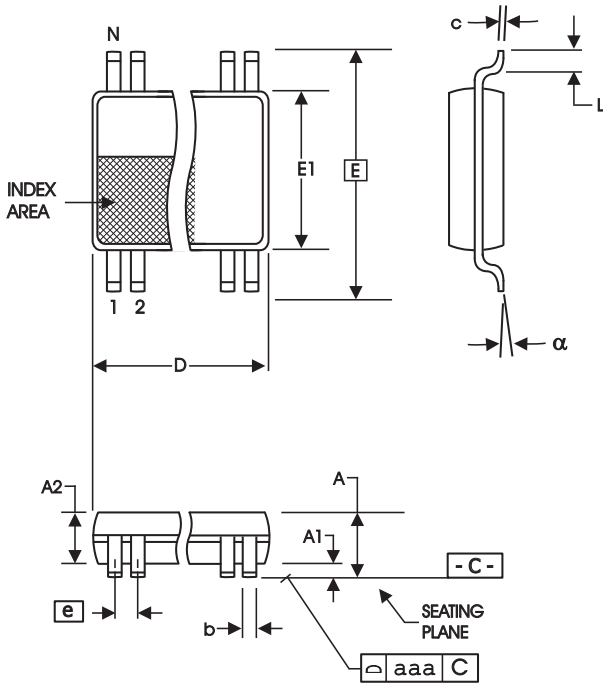

**6.10 mm. Body, 0.50 mm. pitch TSSOP
(240 mil) (0.020 mil)**

SYMBOL	In Millimeters		In Inches	
	COMMON DIMENSIONS	COMMON DIMENSIONS	COMMON DIMENSIONS	COMMON DIMENSIONS
	MIN	MAX	MIN	MAX
A	--	1.20	--	.047
A1	0.05	0.15	.002	.006
A2	0.80	1.05	.032	.041
b	0.17	0.27	.007	.011
c	0.09	0.20	.0035	.008
D	SEE VARIATIONS		SEE VARIATIONS	
E	8.10 BASIC		0.319 BASIC	
E1	6.00	6.20	.236	.244
e	0.50 BASIC		0.020 BASIC	
L	0.45	0.75	.018	.030
N	SEE VARIATIONS		SEE VARIATIONS	
alpha	0°	8°	0°	8°
aaa	--	0.10	--	.004

VARIATIONS

N	D mm.		D (inch)	
	MIN	MAX	MIN	MAX
48	12.40	12.60	.488	.496

Reference Doc.: JEDEC Publication 95, MO-153

10-0039

Ordering Information

ICS95V850yGT

Example:

ICS XXXX y G - T

Designation for tape and reel packaging

Package Type

G = TSSOP

Revision Designator (will not correlate with datasheet revision)

Device Type

Prefix

ICS, AV = Standard Device

[Home](#)

[Applications](#)

[▶ Products](#)

[Purchasing](#)

[Getting Support](#)

[About IDT](#)

[myIDT](#)

[Document Search](#) | [Package Search](#) | [Parametric Search](#) | [Cross Reference Search](#) | [Green & RoHS](#) | [Calculators](#) | [Thermal Data](#) | [Reliability & Quality](#) | [Military](#)

[Add to myIDT \[?\]](#)

[Home](#) > [Products](#) > [Memory Interface Products](#) > [RDIMM](#) > [DDR](#) > [DDR PLL](#) > [95V850A](#)

95V850A (DDR PLL)

Description

2.5 Wide Range Frequency Clock Driver (33MHz-233MHz)

Market Group

DIMM

Additional Info

• Low skew, low jitter PLL clock driver • Feedback pins for input to output synchronization • Spread Spectrum tolerant inputs • With bypass mode mux • Operating frequency 60 to 210 MHz • Universal input (LVTTTL, LVPECL, LVDS, LVCMOS)

You may also like...

Related Orderable Parts

Attributes

95V850AG

95V850AGI

95V850AGIT

95V850AGLF

95V850AGLFT

95V850AGT

Package	TSSOP 48 (PA48)	TSSOP 48 (PA48)	TSSOP 48 (PA48)	TSSOP 48 (PAG48)	TSSOP 48 (PAG48)	TSSOP 48 (PA48)
Speed	NA	NA	NA	NA	NA	NA
Temperature	C	I	I	C	C	C
Voltage	2.5 V	2.5 V	2.5 V	2.5 V	2.5 V	2.5 V
Status	Active	Active	Active	Active	Active	Active
Sample	No	No	No	No	No	No
Minimum Order Quantity	380	190	1000	380	1000	1000
Factory Order Increment	38	38	1000	38	1000	1000

Related Documents

Type	Title	Size	Revision Date
Datasheet	95V850A Datasheet	166 KB	03/27/2006
Product Change Notice	PCN#: TB-0510-05 New Shipping Tube for TSSOP/TVSOP/TSSOP Exposed	202 KB	12/13/2005

[Home](#) | [Site Map](#) | [About IDT](#) | [Press Room](#) | [Investor Relations](#) | [Trademark](#) | [Privacy Policy](#) | [Careers](#) | [Register](#) | [Contact Us](#)

Use of this website signifies your agreement to the [acceptable use and privacy policy](#). Copyright 1997-2007 Integrated Device Technology, Inc. **All Rights Reserved.**