

74VHC139 Dual 2-to-4 Decoder/Demultiplexer

General Description

The VHC139 is an advanced high speed CMOS 2 to 4 line decoder/demultiplexer fabricated with silicon gate CMOS technology. It achieves the high speed operation similar to equivalent Bipolar Schottky TTL while maintaining the CMOS low power dissipation.

The active low enable input can be used for gating or it can be used as a data input for demultiplexing applications. When the enable input is held High, all four outputs are fixed at a high logic level independent of the other inputs. An input protection circuit ensures that 0V to 7V can be applied to the input pins without regard to the supply voltage. This device can be used to interface 5V to 3V systems and two supply systems such as battery back up. This circuit prevents device destruction due to mismatched supply and input voltages.

Features

- Low power dissipation:
 $I_{CC} = 4 \mu A$ (Max.) at $T_A = 25^\circ C$
- High noise immunity: $V_{NIH} = V_{NIL} = 28\% V_{CC}$ (Min.)
- All inputs are equipped with a power down protection function
- Balanced propagation delays: $t_{PLH} \approx t_{PHL}$
- Pin and function compatible with 74HC139

Commercial	Package Number	Package Description
74VHC139M	M16A	16-Lead Molded JEDEC SOIC
74VHC139SJ	M16D	16-Lead Molded EIAJ SOIC
74VHC139MSC	MSC16	16-Lead Molded EIAJ Type 1 SSOP
74VHC139MTC	MTC16	16-Lead Molded JEDEC Type 1 TSSOP
74VHC139N	N16E	16-Lead Molded DIP

Note: Surface mount packages are also available on Tape and Reel. Specify by appending the suffix letter "X" to the ordering code.
EIAJ Type 1 SSOP available on Tape and Reel only, order MSCX

Logic Symbols

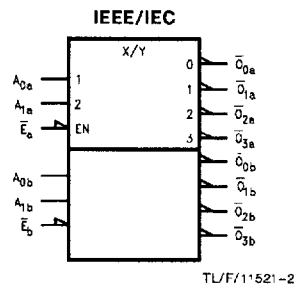
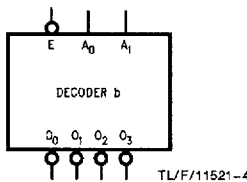
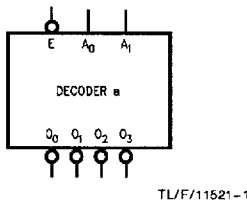

Pin Names	Description
A_0, A_1	Address Inputs
\bar{E}	Enable Inputs
$\bar{O}_0 - \bar{O}_3$	Outputs

Connection Diagrams

Pin Assignment for DIP, SSOP, TSSOP and SOIC

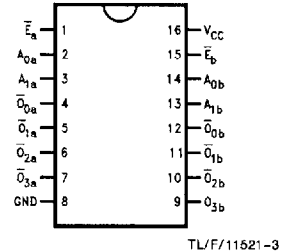

Functional Description

The 'VHC139 is a high-speed dual 2-to-4 decoder/demultiplexer. The device has two independent decoders, each of which accepts two binary weighted inputs (A_0 - A_1) and provides four mutually exclusive active-LOW outputs (\bar{O}_0 - \bar{O}_3). Each decoder has an active-LOW enable (\bar{E}). When \bar{E} is HIGH all outputs are forced HIGH. The enable can be used as the data input for a 4-output demultiplexer application. Each half of the 'VHC139 generates all four minterms of two variables. These four minterms are useful in some applications, replacing multiple gate functions as shown in *Figure 1*, and thereby reducing the number of packages required in a logic network.

Truth Table

Inputs			Outputs			
\bar{E}	A_0	A_1	\bar{O}_0	\bar{O}_1	\bar{O}_2	\bar{O}_3
H	X	X	H	H	H	H
L	L	L	L	H	H	H
L	H	L	H	L	H	H
L	L	H	H	H	L	H
L	H	H	H	H	H	L

H = HIGH Voltage Level
L = LOW Voltage Level
X = Immaterial

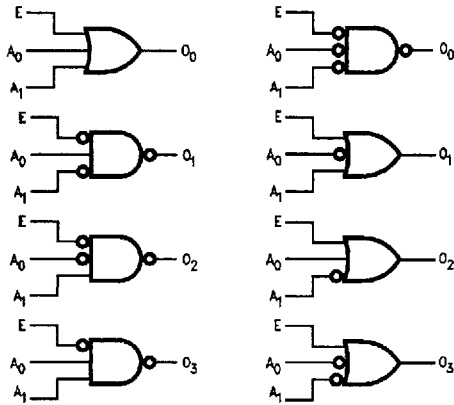

TL/F/11521-8

FIGURE 1. Gate Functions (Each Half)

Logic Diagram

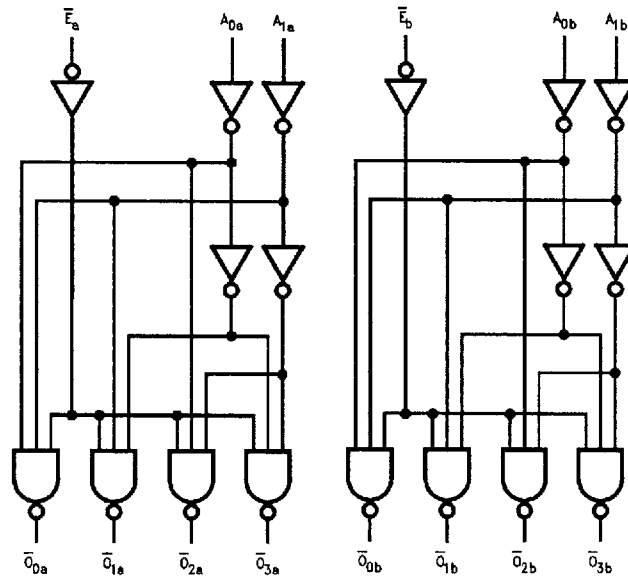

TL/F/11521-8

Please note that this diagram is provided only for the understanding of logic operations and should not be used to estimate propagation delays

Absolute Maximum Ratings (Note 1)

Supply Voltage (V_{CC})	-0.5V to +7.0V
DC Input Voltage (V_{IN})	-0.5V to +7.0V
DC Output Voltage (V_{OUT})	-0.5V to $V_{CC} + 0.5V$
Input Diode Current (I_{IK})	-20 mA
Output Diode Current (I_{OK})	± 20 mA
DC Output Current (I_{OUT})	± 25 mA
DC V_{CC} /GND Current (I_{CC})	± 75 mA
Storage Temperature (T_{STG})	-65°C to +150°C
Lead Temperature (T_L) (Soldering, 10 sec.)	260°C

Note 1: Absolute Maximum Ratings are values beyond which the device may be damaged or have its useful life impaired. The databook specifications should be met, without exception, to ensure that the system design is reliable over its power supply, temperature, and output/input loading variables. National does not recommend operation outside databook specifications.

Recommended Operating Conditions

Supply Voltage (V_{CC})	2.0V to +5.5V
Input Voltage (V_{IN})	0V to +5.5V
Output Voltage (V_{OUT})	0V to V_{CC}
Operating Temperature (T_{OPR})	-40°C to +85°C
74VHC	
Input Rise and Fall Time (t_r, t_f)	
$V_{CC} = 3.3V \pm 0.3V$	0 ~ 100 ns/V
$V_{CC} = 5.0V \pm 0.5V$	0 ~ 20 ns/V

DC Characteristics for 'VHC Family Devices

Symbol	Parameter	V_{CC} (V)	74VHC			74VHC		Units	Conditions	
			$T_A = 25^\circ\text{C}$			$T_A = -40^\circ\text{C}$ to +85°C				
			Min	Typ	Max	Min	Max			
V_{IH}	High Level Input Voltage	2.0 3.0-5.5	1.50			1.50		V		
V_{IL}	Low Level Input Voltage	2.0 3.0-5.5			0.50 0.3 V_{CC}	0.50		V		
V_{OH}	High Level Output Voltage	2.0	1.9	2.0		1.9		V	$V_{IN} = V_{IH}$ or V_{IL}	$I_{OH} = -50 \mu\text{A}$
		3.0	2.9	3.0		2.9				
		4.5	4.4	4.5		4.4		V		$I_{OH} = -4 \text{ mA}$ $I_{OH} = -8 \text{ mA}$
		3.0	2.58			2.48				
4.5	3.94			3.80						
V_{OL}	Low Level Output Voltage	2.0		0.0	0.1		0.1	V	$V_{IN} = V_{IH}$ or V_{IL}	$I_{OL} = 50 \mu\text{A}$
		3.0		0.0	0.1		0.1			
		4.5		0.0	0.1		0.1	V		$I_{OL} = 4 \text{ mA}$ $I_{OL} = 8 \text{ mA}$
		3.0			0.36		0.44			
4.5			0.36		0.44					
I_{IN}	Input Leakage Current	0-5.5			± 0.1		± 1.0	μA	$V_{IN} = 5.5V$ or GND	
I_{CC}	Quiescent Supply Current	5.5			4.0		40.0	μA	$V_{IN} = V_{CC}$ or GND	

AC Electrical Characteristics

Symbol	Parameter	V _{CC} (V)	74VHC			74VHC		Units	Conditions
			T _A = 25°C			T _A = -40°C to +85°C			
			Min	Typ	Max	Min	Max		
t _{PLH} , t _{PHL}	Propagation Delay A _n to \bar{O}_n	3.3 ± 0.3	7.2	11.0	1.0	13.0	ns	C _L = 15 pF	
			9.7	14.5	1.0	16.5		C _L = 50 pF	
		5.0 ± 0.5	5.0	7.2	1.0	8.5	ns	C _L = 15 pF	
			6.5	9.2	1.0	10.5		C _L = 50 pF	
t _{PLH} , t _{PHL}	Propagation Delay E _n to \bar{O}_n	3.3 ± 0.3	6.4	9.2	1.0	11.0	ns	C _L = 15 pF	
			8.9	12.7	1.0	14.5		C _L = 50 pF	
		5.0 ± 0.5	4.4	6.3	1.0	7.5	ns	C _L = 15 pF	
			5.9	8.3	1.0	9.5		C _L = 50 pF	
C _{IN}	Input Capacitance		4	10	10	pF	V _{CC} = Open		
C _{PD}	Power Dissipation Capacitance		26			pF	(Note 1)		

Note 1: C_{PD} is defined as the value of the internal equivalent capacitance which is calculated from the operating current consumption without load. Average operating current can be obtained by the equation: I_{CC} (opr.) = C_{PD} * V_{CC} * f_{IN} + I_{CC}/2 (per decoder).

Ordering Information

The device number is used to form part of a simplified purchasing code, where the package type and temperature range are defined as follows:

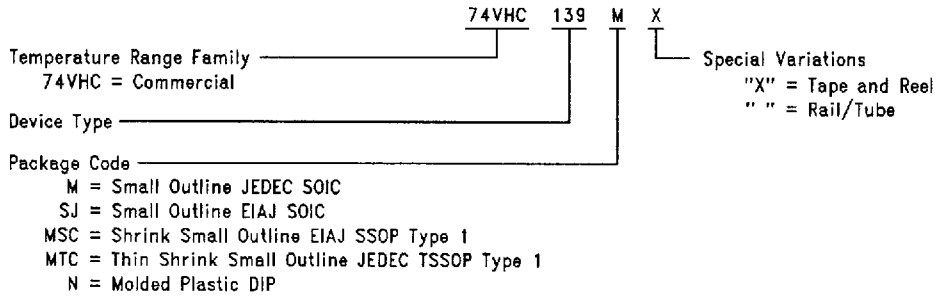

TL/F/11521-11

Physical Dimensions inches (millimeters)

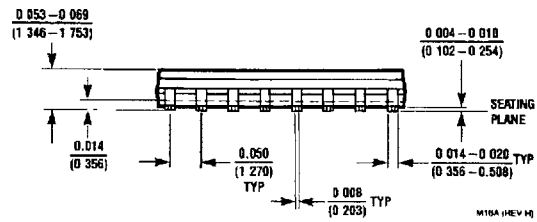
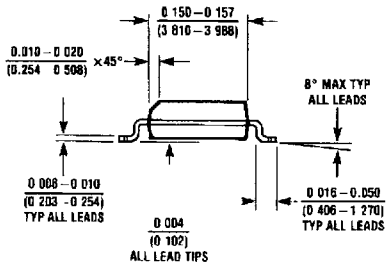
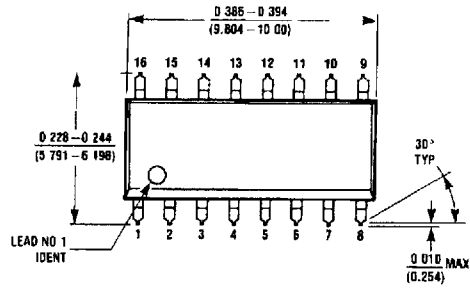

16-Lead Small Outline Integrated Circuit JEDEC SOIC (M)
NS Package Number M16A

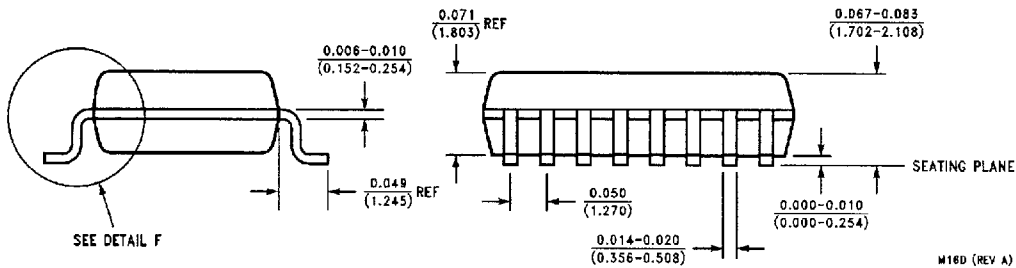
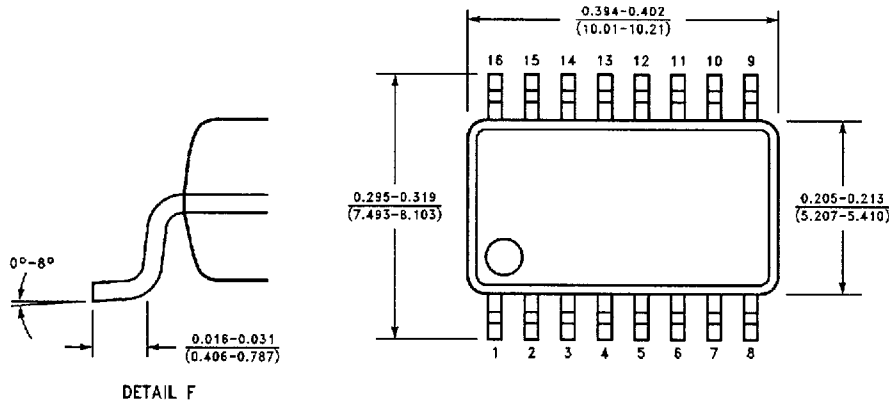

16-Lead Plastic—EIAJ SOIC (SJ)
NS Package Number M16D

Physical Dimensions millimeters (Continued)

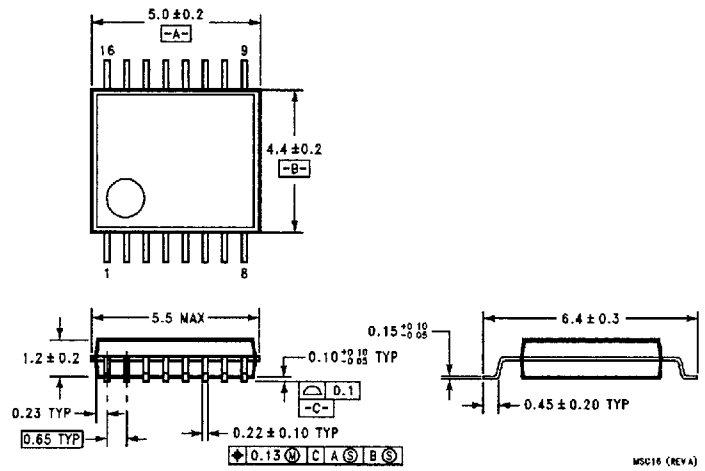

16-Lead Plastic EIAJ SSOP Type I (MSC)
NS Package Number MSC16

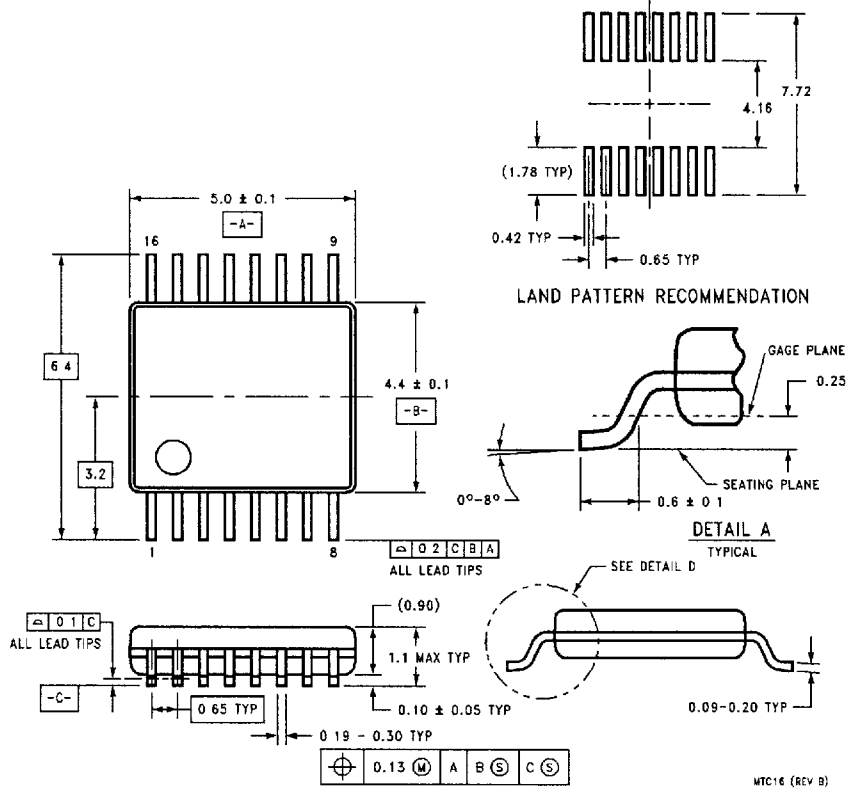

16-Lead Molded JEDEC Type I TSSOP
NS Package Number MTC16

Physical Dimensions inches (millimeters) (Continued)

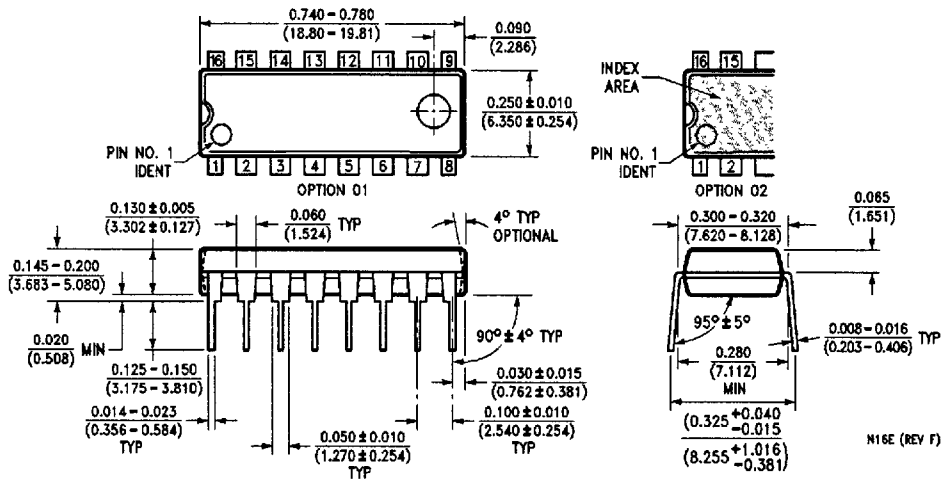

16-Lead Molded Dual In-Line Package
NS Package Number N16E

LIFE SUPPORT POLICY

NATIONAL'S PRODUCTS ARE NOT AUTHORIZED FOR USE AS CRITICAL COMPONENTS IN LIFE SUPPORT DEVICES OR SYSTEMS WITHOUT THE EXPRESS WRITTEN APPROVAL OF THE PRESIDENT OF NATIONAL SEMICONDUCTOR CORPORATION. As used herein:

1. Life support devices or systems are devices or systems which, (a) are intended for surgical implant into the body, or (b) support or sustain life, and whose failure to perform, when properly used in accordance with instructions for use provided in the labeling, can be reasonably expected to result in a significant injury to the user.
2. A critical component is any component of a life support device or system whose failure to perform can be reasonably expected to cause the failure of the life support device or system, or to affect its safety or effectiveness.

National Semiconductor Corporation
1111 West Bardin Road
Arlington, TX 76017
Tel 1(800) 272-9959
Fax 1(800) 737-7018

National Semiconductor Europe
Fax: (+49) 0-180-530 85 86
Email: cnjwge@tevm2.nsc.com
Deutsch Tel (+49) 0-180-530 85 85
English Tel (+49) 0-180-532 78 32
Français Tel (+49) 0-180-532 93 58
Italiano Tel (+49) 0-180-534 16 80

National Semiconductor Hong Kong Ltd.
13th Floor, Straight Block,
Ocean Centre, 5 Canton Rd.
Tsimshatsui, Kowloon
Hong Kong
Tel: (852) 2737-1600
Fax: (852) 2736-9960

National Semiconductor Japan Ltd.
Tel 81-043-299-2309
Fax 81-043-299-2408

National does not assume any responsibility for use of any circuitry described, no circuit patent licenses are implied and National reserves the right at any time without notice to change said circuitry and specifications.