



BCD-TO-SEVEN-SEGMENT DECODERS/DRIVERS

The SN54/74LS247 thru SN54/74LS249 are BCD-to-Seven-Segment Decoder/Drivers.

The LS247 and LS248 are functionally and electrically identical to the LS47 and LS48 with the same pinout configuration. The LS249 is a 16-pin version of the 14-pin LS49 and includes full functional capability for lamp test and ripple blanking which was not available in the LS49.

The composition of all characters, except the 6 and 9 are identical between the LS247, 248, 249 and the LS47, 48 and 49. The LS47 thru 49 compose the and without tails, the LS247 thru 249 compose the and with the tails. The LS247 has active-low outputs for direct drive of indicators. The LS248 and 249 have active-high outputs for driving lamp buffers.

All types feature a lamp test input and have full ripple-blanking input/output controls. On all types an automatic leading and/or trailing-edge zero-blanking control (RBI and RBO) is incorporated and an overriding blanking input (BI) is contained which may be used to control the lamp intensity by pulsing or to inhibit the output's lamp test may be performed at any time when the BI/RBO node is at high level. Segment identification and resultant displays are shown below. Display pattern for BCD input counts above 9 are unique symbols to authenticate input conditions.

LS247

- Open-Collector Outputs Drive Indicators Directly
- Lamp-Test Provision
- Leading/Trailing Zero Suppression

LS248

- Internal Pull-Ups Eliminate Need for External Resistors
- Lamp-Test Provision
- Leading/Trailing Zero Suppression

LS249

- Open-Collector Outputs
- Lamp-Test Provision
- Leading/Trailing Zero Suppression

**SN54/74LS247
SN54/74LS248
SN54/74LS249**

**BCD-TO-SEVEN-SEGMENT
DECODERS/DRIVERS
LOW POWER SCHOTTKY**

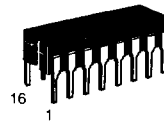

**J SUFFIX
CERAMIC
CASE 620-09**

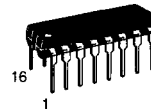

**N SUFFIX
PLASTIC
CASE 648-08**

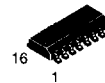

**D SUFFIX
SOIC
CASE 751B-03**

ORDERING INFORMATION

SN54LSXXXJ Ceramic
SN74LSXXXN Plastic
SN74LSXXXDW SOIC

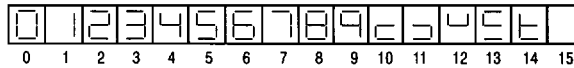

NUMERICAL DESIGNATIONS AND RESULTANT DISPLAYS

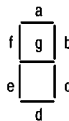

**SEGMENT
IDENTIFICATION**

SN54/74LS247 • SN54/74LS248 • SN54/74LS249

SN54/74LS247
(TOP VIEW)

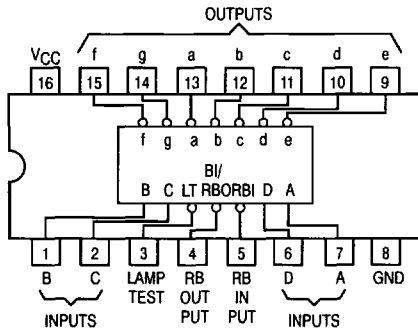

SN54/74LS248
SN54/74LS259
(TOP VIEW)

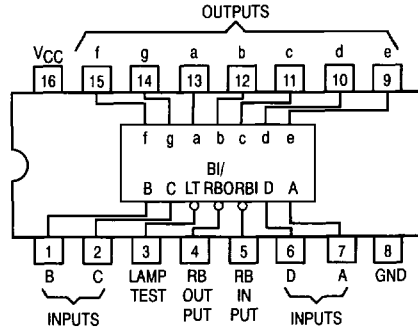

ALL CIRCUIT TYPES FEATURE LAMP INTENSITY MODULATION CAPABILITY

TYPE	DRIVER OUTPUTS				TYPICAL POWER DISSIPATION
	ACTIVE LEVEL	OUTPUT CONFIGURATION	SINK CURRENT	MAX VOLTAGE	
SN54LS247	low	open-collector	12 mA	15 V	35 mW
SN54LS248	high	2.0 kΩ pull-up	2.0 mA	5.5 V	125 mW
SN54LS249	high	open-collector	4.0 mA	5.5 V	40 mW
SN74LS247	low	open-collector	24 mA	15 V	35 mW
SN74LS248	high	2.0 kΩ pull-up	6.0 mA	5.5 V	125 mW
SN74LS249	high	open-collector	8.0 mA	5.5 V	40 mW

LOGIC DIAGRAM

LS247

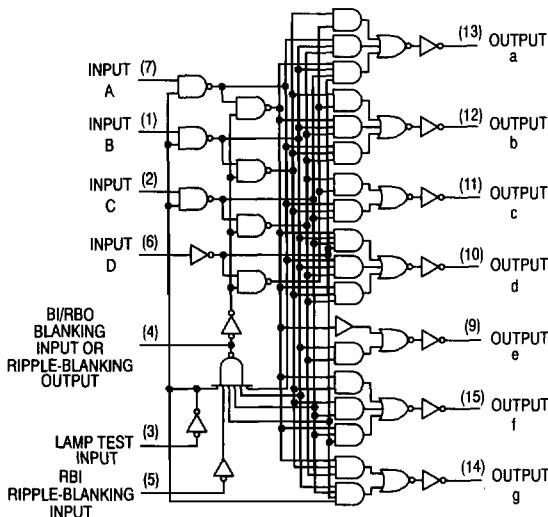

LS248, LS249

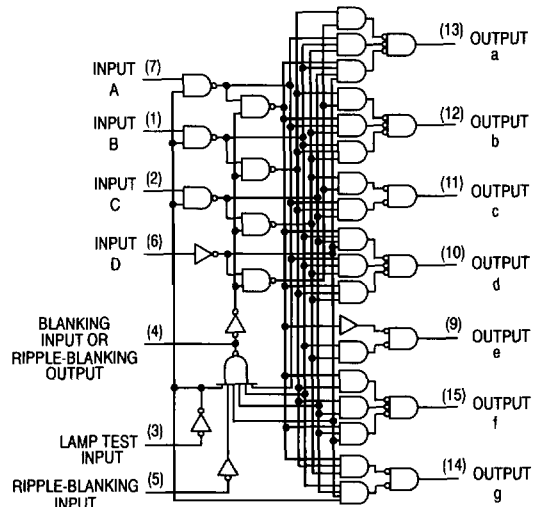

SN54/74LS247 • SN54/74LS248 • SN54/74LS249

LS247 FUNCTION TABLE

DECIMAL OR FUNCTION	INPUTS						BI/RBO [†]	OUTPUTS							NOTE
	LT	RBI	D	C	B	A		a	b	c	d	e	f	g	
0	H	H	L	L	L	L	H	ON	ON	ON	ON	ON	ON	OFF	
1	H	X	L	L	L	H	H	OFF	ON	ON	OFF	OFF	OFF	OFF	
2	H	X	L	L	H	L	H	ON	ON	OFF	ON	ON	OFF	ON	
3	H	X	L	L	H	H	H	ON	ON	ON	ON	OFF	OFF	ON	
4	H	X	L	H	L	L	H	OFF	ON	ON	OFF	OFF	ON	ON	
5	H	X	L	H	L	H	H	ON	OFF	ON	ON	OFF	ON	ON	
6	H	X	L	H	H	L	H	ON	OFF	ON	ON	ON	ON	ON	
7	H	X	L	H	H	H	H	ON	ON	ON	OFF	OFF	OFF	OFF	
8	H	X	H	L	L	L	H	ON	ON	ON	ON	ON	ON	ON	
9	H	X	H	L	L	H	H	ON	ON	ON	ON	OFF	ON	ON	
10	H	X	H	L	H	L	H	OFF	OFF	OFF	ON	ON	OFF	ON	
11	H	X	H	L	H	H	H	OFF	OFF	ON	ON	OFF	OFF	ON	
12	H	X	H	H	L	L	H	OFF	ON	OFF	OFF	OFF	ON	ON	
13	H	X	H	H	L	H	H	ON	OFF	OFF	ON	OFF	ON	ON	
14	H	X	H	H	H	L	H	OFF	OFF	OFF	ON	ON	ON	ON	
15	H	X	H	H	H	H	H	OFF	OFF	OFF	OFF	OFF	OFF	OFF	
BI	X	X	X	X	X	X	L	OFF	OFF	OFF	OFF	OFF	OFF	OFF	2
RBI	H	L	L	L	L	L	L	OFF	OFF	OFF	OFF	OFF	OFF	OFF	3
LT	L	X	X	X	X	X	H	ON	ON	ON	ON	ON	ON	ON	4

LS248, LS249 FUNCTION TABLE

DECIMAL OR FUNCTION	INPUTS						BI/RBO [†]	OUTPUTS							NOTE
	LT	RBI	D	C	B	A		a	b	c	d	e	f	g	
0	H	H	L	L	L	L	H	H	H	H	H	H	H	L	1
1	H	X	L	L	L	H	H	L	H	H	L	L	L	L	1
2	H	X	L	L	H	L	H	H	H	L	H	H	L	H	
3	H	X	L	L	H	H	H	H	H	H	L	L	L	H	
4	H	X	L	H	L	L	H	L	H	H	L	L	H	H	
5	H	X	L	H	L	H	H	H	L	H	H	L	H	H	
6	H	X	L	H	H	L	H	H	H	H	H	H	H	H	
7	H	X	L	H	H	H	H	H	H	H	L	L	L	L	1
8	H	X	H	L	L	L	H	H	H	H	H	H	H	H	
9	H	X	H	L	L	H	H	H	H	H	L	H	H	H	
10	H	X	H	L	H	L	H	L	L	L	H	H	L	H	
11	H	X	H	L	H	H	H	L	L	H	H	L	L	H	
12	H	X	H	H	L	L	H	L	H	L	L	L	H	H	
13	H	X	H	H	L	H	H	H	L	L	L	H	H	H	
14	H	X	H	H	H	L	H	L	L	L	H	H	H	H	
15	H	X	H	H	H	H	H	L	L	L	L	L	L	L	
BI	X	X	X	X	X	X	L	L	L	L	L	L	L	L	2
RBI	H	L	L	L	L	L	L	L	L	L	L	L	L	L	3
LT	L	X	X	X	X	X	H	H	H	H	H	H	H	H	4

H = HIGH Level, L = LOW Level, X = Irrelevant

NOTES: 1. The blanking input (BI) must be open or held at a high logic level when output functions 0 through 15 are desired. The ripple-blanking input (RBI) must be open or high if blanking of a decimal zero is not desired.

2. When a low logic level is applied directly to the blanking input (BI), all segment outputs are off regardless of the level of any other input.

3. When ripple-blanking input (RBI) and inputs A, B, C, and D are at a low level with the lamp test input high, all segment outputs go off and the ripple-blanking output (RBO) goes to a low level (response condition).

4. When the blanking input/ripple blanking output (BI/RBO) is open or held high and a low is applied to the lamp-test input, all segment outputs are on.

[†] BI/RBO is wire-AND logic serving as blanking input (BI) and/or ripple-blanking output (RBO).

SN54/74LS247

GUARANTEED OPERATING RANGES

Symbol	Parameter		Min	Typ	Max	Unit
V _{CC}	Supply Voltage	54 74	4.5 4.75	5.0 5.0	5.5 5.25	V
T _A	Operating Ambient Temperature Range	54 74	-55 0	25 25	125 70	°C
I _{OH}	Output Current — High BI/RBO	54, 74			-50	μA
I _{OL}	Output Current — Low BI/RBO	54 74			1.6 3.2	mA
V _{O(off)}	Off-State Output Voltage a-g	54, 74			15	V
I _{O(on)}	On-State Output Current a-g	54 74			12 24	mA

DC CHARACTERISTICS OVER OPERATING TEMPERATURE RANGE (unless otherwise specified)

Symbol	Parameter	Limits			Unit	Test Conditions		
		Min	Typ	Max				
V _{IH}	Input HIGH Voltage	2.0			V	Guaranteed Input HIGH Voltage for All Inputs		
V _{IL}	Input LOW Voltage	54		0.7	V	Guaranteed Input LOW Voltage for All Inputs		
		74		0.8				
V _{IK}	Input Clamp Diode Voltage		-0.65	-1.5	V	V _{CC} = MIN, I _{IN} = -18 mA		
V _{OH}	Output HIGH Voltage BI/RBO	54	2.4	4.2	V	V _{CC} = MIN, I _{OH} = MAX, V _{IN} = V _{IH} or V _{IL} per Truth Table		
		74	2.4	4.2	V			
V _{OL}	Output LOW Voltage BI/RBO	54, 74		0.25	0.4	I _{OL} = 1.6 mA	V _{CC} = V _{CC} MIN, V _{IN} = V _{IL} or V _{IH} per Truth Table	
		74		0.35	0.5	I _{OL} = 3.2 mA		
I _{O(off)}	Off-State Output Current a-g	54, 74			250	μA	V _{CC} = MAX, V _{IH} = 2.0 V, V _{O(off)} = 15 V, V _{IL} = MAX	
V _{O(on)}	On-State Output Voltage a-g	54, 74		0.25	0.4	V	I _{O(on)} = 12 mA	V _{CC} = MIN, V _{IH} = 2.0 V, V _{IL} per Truth Table
		74		0.35	0.5	V	I _{O(on)} = 24 mA	
I _{IH}	Input HIGH Current				20	μA	V _{CC} = MAX, V _{IN} = 2.7 V	
					0.1	mA	V _{CC} = MAX, V _{IN} = 7.0 V	
I _{IL}	Input LOW Current Any Input, except BI/RBO BI/RBO				-0.4	mA	V _{CC} = MAX, V _{IN} = 0.4 V	
					-1.2			
I _{OS}	Short Circuit Current BI/RBO (Note 1)	-0.3		-2.0		mA	V _{CC} = MAX	
I _{CC}	Power Supply Current		7.0	13		mA	V _{CC} = MAX	

Note 1: Not more than one output should be shorted at a time, nor for more than 1 second.

AC CHARACTERISTICS (V_{CC} = 5.0 V, T_A = 25°C)

Symbol	Parameter	Limits			Unit	Test Conditions
		Min	Typ	Max		
t _{PLH}	Turn-Off Time from A Input			100	ns	C _L = 15 pF, R _L = 665 Ω
t _{PHL}	Turn-On Time from A Input			100		
t _{PHL}	Turn-Off Time from RBI Input			100	ns	
t _{PLH}	Turn-On Time from RBI Input			100		

SN54/74LS248

GUARANTEED OPERATING RANGES

Symbol	Parameter		Min	Typ	Max	Unit
V _{CC}	Supply Voltage	54 74	4.5 4.75	5.0 5.0	5.5 5.25	V
T _A	Operating Ambient Temperature Range	54 74	-55 0	25 25	125 70	°C
I _{OH}	Output Current — High BI/RBO a-g	54, 74 54, 74			-50 -100	μA
I _{OL}	Output Current — Low BI/RBO BI/RBO a-g a-g	54 74 54 74			1.6 3.2 2.0 6.0	mA

DC CHARACTERISTICS OVER OPERATING TEMPERATURE RANGE (unless otherwise specified)

Symbol	Parameter	Limits			Unit	Test Conditions	
		Min	Typ	Max			
V _{IH}	Input HIGH Voltage	2.0			V	Guaranteed Input HIGH Voltage for All Inputs	
V _{IL}	Input LOW Voltage	54		0.7	V	Guaranteed Input LOW Voltage for All Inputs	
		74		0.8			
V _{IK}	Input Clamp Diode Voltage		-0.65	-1.5	V	V _{CC} = MIN, I _{IN} = -18 mA	
V _{OH}	Output HIGH Voltage a-g and BI/RBO	54	2.4	4.2	V	V _{CC} = MIN, I _{OH} = MAX, V _{IN} = V _{IH} or V _{IL} per Truth Table	
		74	2.4	4.2	V		
I _{OH}	Output Current a-g	54, 74	-1.3	-2.0	mA	V _{CC} = MIN, V _O = 0.85 V, Input Conditions as for V _{OH}	
V _{OL}	Output LOW Voltage a-g	54, 74		0.25	0.4	V	V _{CC} = MIN, V _{IH} = 2.0 V, V _{IL} = per Truth Table
		74		0.35	0.5		
	BI/RBO	54, 74		0.25	0.4	V	
		74		0.35	0.5		
I _{IH}	Input HIGH Current Any Input, except BI/RBO			20	μA	V _{CC} = MAX, V _{IN} = 2.7 V	
				0.1	mA	V _{CC} = MAX, V _{IN} = 7.0 V	
I _{IL}	Input LOW Current Any Input, except BI/RBO			-0.4	mA	V _{CC} = MAX, V _{IN} = 0.4 V	
				-1.2			
I _{OS}	Short Circuit Current BI/RBO (Note 1)		-0.3	-2.0	mA	V _{CC} = MAX	
I _{CC}	Power Supply Current		25	38	mA	V _{CC} = MAX	

Note 1: Not more than one output should be shorted at a time, nor for more than 1 second.

AC CHARACTERISTICS (V_{CC} = 5.0 V, T_A = 25°C)

Symbol	Parameter	Limits			Unit	Test Conditions
		Min	Typ	Max		
t _{PLH}	Propagation Delay Time, High-to-Low-Level Output from A Input			100	ns	C _L = 15 pF R _L = 4.0 kΩ
t _{PHL}	Propagation Delay Time, Low-to-High-Level Output from A Input			100		
t _{PHL}	Propagation Delay Time, High-to-Low-Level Output from RBI Input			100	ns	C _L = 15 pF R _L = 6.0 kΩ
t _{PLH}	Propagation Delay Time, Low-to-High-Level Output from RBI Input			100		

SN54/74LS249

GUARANTEED OPERATING RANGES

Symbol	Parameter		Min	Typ	Max	Unit
V _{CC}	Supply Voltage	54 74	4.5 4.75	5.0 5.0	5.5 5.25	V
T _A	Operating Ambient Temperature Range	54 74	-55 0	25 25	125 70	°C
I _{OH}	Output Current — High BI/RBO	54, 74			-50	μA
I _{OL}	Output Current — Low BI/RBO BI/RBO	54 74			1.6 3.2	mA
V _{OH}	Output Voltage — High a-g	54, 74			5.5	V
I _{OL}	Output Current — Low a-g a-g	54 74			4.0 8.0	mA

DC CHARACTERISTICS OVER OPERATING TEMPERATURE RANGE (unless otherwise specified)

Symbol	Parameter	Limits			Unit	Test Conditions	
		Min	Typ	Max			
V _{IH}	Input HIGH Voltage	2.0			V	Guaranteed Input HIGH Voltage for All Inputs	
V _{IL}	Input LOW Voltage	54		0.7	V	Guaranteed Input LOW Voltage for All Inputs	
		74		0.8			
V _{IK}	Input Clamp Diode Voltage		-0.65	-1.5	V	V _{CC} = MIN, I _{IN} = -18 mA	
V _{OH}	Output HIGH Voltage BI/RBO	54	2.4	4.2	V	V _{CC} = MIN, I _{OH} = MAX, V _{IN} = V _{IH} or V _{IL} per Truth Table	
		74	2.4	4.2	V		
I _{OH}	Output HIGH Current a-g	54, 74		250	μA	V _{CC} = MIN, V _{IH} = 2.0 V, V _{OH} = 5.5 V, V _{IL} = MAX	
V _{OL}	Output LOW Voltage BI/RBO	54, 74		0.25	0.4	V	V _{CC} = MIN, V _{IH} = 2.0 V, V _{IL} = per Truth Table
		74		0.35	0.5	V	
	a-g	54, 74		0.25	0.4	V	
		74		0.35	0.5		
I _{IH}	Input HIGH Current Any Input, except BI/RBO			20	μA	V _{CC} = MAX, V _{IN} = 2.7 V	
				0.1	mA	V _{CC} = MAX, V _{IN} = 7.0 V	
I _{IL}	Input LOW Current Any Input, except BI/RBO BI/RBO			-0.4	mA	V _{CC} = MAX, V _{IN} = 0.4 V	
				-1.2			
I _{OS}	Short Circuit Current BI/RBO (Note 1)	-0.3		-2.0	mA	V _{CC} = MAX	
I _{CC}	Power Supply Current		8.0	15	mA	V _{CC} = MAX	

Note 1: Not more than one output should be shorted at a time, nor for more than 1 second.

AC CHARACTERISTICS (V_{CC} = 5.0 V, T_A = 25°C)

Symbol	Parameter	Limits			Unit	Test Conditions
		Min	Typ	Max		
t _{PHL}	Propagation Delay Time, High-to-Low-Level Output from A Input			100	ns	C _L = 15 pF, R _L = 2.0 Ω
t _{PLH}	Propagation Delay Time, Low-to-High-Level Output from A Input			100		
t _{PHL}	Propagation Delay Time, High-to-Low-Level Output from RBI Input			100	ns	C _L = 15 pF, R _L = 6.0 Ω
t _{PLH}	Propagation Delay Time, Low-to-High-Level Output from RBI Input			100		