

NOTICE OF REVISION (NOR)		1. DATE (YYMMDD) 98-09-09	Form Approved OMB No. 0704-0188
THIS REVISION DESCRIBED BELOW HAS BEEN AUTHORIZED FOR THE DOCUMENT LISTED.			
Public reporting burden for this collection is estimated to average 2 hours per response, including the time for reviewing instructions, searching existing data sources, gathering and maintaining the data needed, and completing and reviewing the collection of information. Send comments regarding this burden estimate or any other aspect of this collection of information, including suggestions for reducing this burden, to Department of Defense, Washington Headquarters Services, Directorate for Information Operations and Reports, 1215 Jefferson Davis Highway, Suite 1204, Arlington, VA 22202-4302, and to the Office of Management and Budget, Paperwork Reduction Project (07040188), Washington, DC 20503. PLEASE DO NOT RETURN YOUR COMPLETED FORM TO EITHER OF THESE ADDRESSES. RETURN COMPLETED FORM TO THE GOVERNMENT ISSUING CONTRACTING OFFICER FOR THE CONTRACT/ PROCURING ACTIVITY NUMBER LISTED IN ITEM 2 OF THIS FORM.		2. PROCURING ACTIVITY NO.	
		3. DODAAC	
4. ORIGINATOR	b. ADDRESS (Street, City, State, Zip Code) Defense Supply Center, Columbus 3990 East Broad Street Columbus, OH 43216-5000	5. CAGE CODE 67268	6. NOR NO. 5962-R141-98
a. TYPED NAME (First, Middle Initial, Last)		7. CAGE CODE 67268	8. DOCUMENT NO. 5962-92147
9. TITLE OF DOCUMENT MICROCIRCUIT, DIGITAL, ADVANCED BIPOLAR CMOS, OCTAL, BUFFER/DRIVER, WITH NON-INVERTING THREE-STATE OUTPUTS, TTL COMPATIBLE, MONOLITHIC SILICON		10. REVISION LETTER	
		a. CURRENT A	b. NEW B
11. ECP NO.			
12. CONFIGURATION ITEM (OR SYSTEM) TO WHICH ECP APPLIES All			
13. DESCRIPTION OF REVISION			
<p>Sheet 1: Revisions ltr column; add "B". Revisions description column; add "Changes in accordance with NOR 5962-R141-98". Revisions date column; add "98-09-09". Revision level block; change from "A" to "B". Rev status of sheets; for sheet 1 change from "A" to "B", for sheet 12, add "B".</p> <p>Sheet 12: Figure 3, logic diagram; replace with the following:</p>			
14. THIS SECTION FOR GOVERNMENT USE ONLY			
a. (X one)	X	(1) Existing document supplemented by the NOR may be used in manufacture.	
		(2) Revised document must be received before manufacturer may incorporate this change.	
		(3) Custodian of master document shall make above revision and furnish revised document.	
b. ACTIVITY AUTHORIZED TO APPROVE CHANGE FOR GOVERNMENT DSCC-VAC		c. TYPED NAME (First, Middle Initial, Last) Monica L. Poelking	
d. TITLE Chief, Custom Microelectronics Team	e. SIGNATURE Monica L. Poelking		f. DATE SIGNED (YYMMDD) 98-09-09
15a. ACTIVITY ACCOMPLISHING REVISION DSCC-VAC	b. REVISION COMPLETED (Signature) Joseph A. Kerby		c. DATE SIGNED (YYMMDD) 98-09-09

NOTICE OF REVISION (NOR)		1. DATE (YYMMDD) 94-06-15	Form Approved OMB No. 0704-0188
This revision described below has been authorized for the document listed.			
Public reporting burden for this collection is estimated to average 2 hours per response, including the time for reviewing instructions, searching existing data sources, gathering and maintaining the data needed, and completing and reviewing the collection of information. Send comments regarding this burden estimate or any other aspect of this collection of information, including suggestions for reducing this burden, to Department of Defense, Washington Headquarters Services, Directorate for Information Operations and Reports, 1215 Jefferson Davis Highway, Suite 1204, Arlington, VA 22202-4302, and to the Office of Management and Budget, Paperwork Reduction Project (0704-0188), Washington, DC 20503. PLEASE DO NOT RETURN YOUR COMPLETED FORM TO EITHER OF THESE ADDRESSES. RETURN COMPLETED FORM TO THE GOVERNMENT ISSUING CONTRACTING OFFICER FOR THE CONTRACT/ PROCURING ACTIVITY NUMBER LISTED IN ITEM 2 OF THIS FORM.			2. PROCURING ACTIVITY NO.
			3. DODAAC
4. ORIGINATOR	b. ADDRESS (Street, City, State, Zip Code) Defense Electronics Supply Center 1507 Wilmington Pike Dayton, OH 45444-5765	5. CAGE CODE 67268	6. NOR NO. 5962-R214-94
a. TYPED NAME (First, Middle Initial, Last)		7. CAGE CODE 67268	8. DOCUMENT NO. 5962-92147
9. TITLE OF DOCUMENT MICROCIRCUIT, DIGITAL, ADVANCED BIPOLAR CMOS, OCTAL BUFFER/DRIVER WITH NONINVERTING THREE-STATE OUTPUTS, TTL COMPATIBLE INPUTS, MONOLITHIC SILICON		10. REVISION LETTER	
		a. CURRENT Initial	b. NEW A
11. ECP NO. N/A			
12. CONFIGURATION ITEM (OR SYSTEM) TO WHICH ECP APPLIES ALL			
13. DESCRIPTION OF REVISION			
<p>Sheet 1: Revisions ltr column; add "A". Revisions description column; add "Changes in accordance with NOR 5962-R214-94". Revisions date column; add "94-06-15". Revision level block; add "A". Rev status of sheets; for sheets 1, 7 and 9, add "A".</p> <p>Sheet 7: Table I, input current high, I_{IH}, change maximum limit from "+1.0 μA" to "+2.0 μA". Table I, input current low, I_{IL}, change maximum limit from "-1.0 μA" to "-2.0 μA". Table I, quiescent supply current delta TTL input levels, ΔI_{CC}, change maximum limit from "1.5 mA" to "2.5 mA" for data inputs, outputs enabled and control inputs (2 places). Revision level block; add "A"</p> <p>Sheet 9: Table I, propagation delay time, output enable, \overline{OEN} to mYn, t_{PZH}, change maximum limits from "4.6 ns" to "5.5 ns" for subgroup 9 and from "5.7 ns" to "6.5 ns" for subgroups 10 and 11. Revision level block; add "A"</p> <p>Sheet 18: Table II, interim electrical parameters, subgroups column; delete "1" for device class Q. Revision level block; add "A".</p>			
14. THIS SECTION FOR GOVERNMENT USE ONLY			
a. (X one)	X	(1) Existing document supplemented by the NOR may be used in manufacture.	
		(2) Revised document must be received before manufacturer may incorporate this change.	
		(3) Custodian of master document shall make above revision and furnish revised document.	
b. ACTIVITY AUTHORIZED TO APPROVE CHANGE FOR GOVERNMENT DESC-ELDC		c. TYPED NAME (First, Middle Initial, Last) Monica L. Poelking	
d. TITLE Chief, Custom Microelectronics	e. SIGNATURE Monica L. Poelking		f. DATE SIGNED (YYMMDD) 94-06-15
15a. ACTIVITY ACCOMPLISHING REVISION DESC-ELDC	b. REVISION COMPLETED (Signature) Joseph A. Kerby		c. DATE SIGNED (YYMMDD) 94-06-15

REVISIONS

LTR

DESCRIPTION

DATE (YR-MO-DA)

APPROVED

REV

SHEET

REV

SHEET

15

16

17

18

19

20

REV STATUS OF SHEETS

REV

SHEET

1

2

3

4

5

6

7

8

9

10

11

12

13

14

PMIC N/A

PREPARED BY
Joseph A. Kerby

DEFENSE ELECTRONICS SUPPLY CENTER
DAYTON, OHIO 45444

**STANDARDIZED
MILITARY
DRAWING**

CHECKED BY
Thomas J. Ricciuti

MICROCIRCUIT, DIGITAL, ADVANCED
BIPOLAR CMOS, OCTAL BUFFER/DRIVER,
WITH NON-INVERTING THREE-STATE
OUTPUTS, TTL COMPATIBLE, MONOLITHIC
SILICON

APPROVED BY
Monica L. Poelking

DRAWING APPROVAL DATE
93-08-11

SIZE
A

CAGE CODE
67268

5962-92147

REVISION LEVEL

SHEET 1 OF 20

THIS DRAWING IS AVAILABLE
FOR USE BY ALL DEPARTMENTS
AND AGENCIES OF THE
DEPARTMENT OF DEFENSE

AMSC N/A

1. SCOPE

1.1 Scope. This drawing forms a part of a one part - one part number documentation system (see 6.6 herein). Two product assurance classes consisting of military high reliability (device classes B, Q, and M) and space application (device classes S and V), and a choice of case outlines and lead finishes are available and are reflected in the Part or Identifying Number (PIN). Device class M microcircuits represent non-JAN class B microcircuits in accordance with 1.2.1 of MIL-STD-883, "Provisions for the use of MIL-STD-883 in conjunction with compliant non-JAN devices". When available, a choice of radiation hardness assurance (RHA) levels are reflected in the PIN.

1.2 PIN. The PIN shall be as shown in the following example:

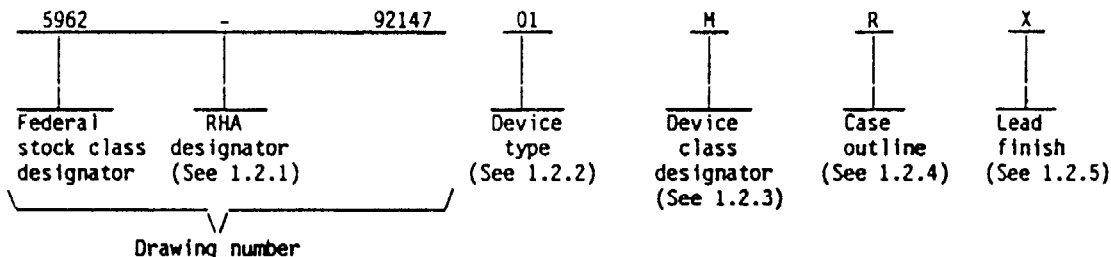

1.2.1 RHA designator. Device classes M, B, and S RHA marked devices shall meet the MIL-M-38510 specified RHA levels and shall be marked with the appropriate RHA designator. Device classes Q and V RHA marked devices shall meet the MIL-I-38535 specified RHA levels and shall be marked with the appropriate RHA designator. A dash (-) indicates a non-RHA device.

1.2.2 Device type(s). The device type(s) shall identify the circuit function as follows:

<u>Device type</u>	<u>Generic number</u>	<u>Circuit function</u>
01	54ABT244	Octal buffers/drivers with three-state outputs, TTL compatible inputs

1.2.3 Device class designator. The device class designator shall be a single letter identifying the product assurance level as follows:

<u>Device class</u>	<u>Device requirements documentation</u>
M	Vendor self-certification to the requirements for non-JAN class B microcircuits in accordance with 1.2.1 of MIL-STD-883
B or S	Certification and qualification to MIL-M-38510
Q or V	Certification and qualification to MIL-I-38535

1.2.4 Case outline(s). The case outline(s) shall be as designated in MIL-STD-1835, and as follows:

<u>Outline letter</u>	<u>Descriptive designator</u>	<u>Terminals</u>	<u>Package style</u>
R	GDIPI-T20 or CDIP2-T20	20	Dual-in-line
S	GDFP2-F20 or CDFP3-F20	20	Flat pack
Z	CQCC1-N20	20	Square chip carrier

1.2.5 Lead finish. The lead finish shall be as specified in MIL-M-38510 for classes M, B, and S or MIL-I-38535 for classes Q and V. Finish letter "X" shall not be marked on the microcircuit or its packaging. The "X" designation is for use in specifications when lead finishes A, B, and C are considered acceptable and interchangeable without preference.

STANDARDIZED MILITARY DRAWING DEFENSE ELECTRONICS SUPPLY CENTER DAYTON, OHIO 45444	SIZE A		5962-92147
		REVISION LEVEL	SHEET 2

1.3 Absolute maximum ratings. 1/ 2/ 3/

Supply voltage range (V_{CC})	- - - - -	-0.5 V dc to +7.0 V dc
DC input voltage range (V_{IN})	- - - - -	-0.5 V dc to + 7.0 V dc 4/
DC output voltage range (V_{OUT})	- - - - -	-0.5 V dc to + 5.5 V dc 4/
DC input clamp current (I_{IK}) ($V_{IN} < 0.0$ V)	- - - - -	-18 mA
DC output clamp current (I_{OK}) ($V_{OUT} < 0.0$ V)	- - - - -	-50 mA
DC output current (I_{OL}) (per output)	- - - - -	+96 mA
Storage temperature range (T_{STG})	- - - - -	-65°C to +150°C
Lead temperature (soldering, 10 seconds)	- - - - -	+300°C
Thermal resistance, junction-to-case (θ_{JC})	- - - - -	See MIL-STD-1835
Junction temperature (T_J)	- - - - -	+175°C
Maximum power dissipation (P_D)	- - - - -	500 mW

1.4 Recommended operating conditions. 2/ 3/

Supply voltage range (V_{CC})	- - - - -	+4.5 V dc to +5.5 V dc
Input voltage range (V_{IN})	- - - - -	+0.0 V dc to V_{CC}
Output voltage range (V_{OUT})	- - - - -	+0.0 V dc to V_{CC}
Maximum low level input voltage (V_{IL})	- - - - -	0.8 V
Minimum high level input voltage (V_{IH})	- - - - -	2.0 V
Case operating temperature range (T_C)	- - - - -	-55°C to +125°C
Maximum input rise and fall rate (t_C, t_f)	- - - - -	5 ns/V
Maximum high level output current (I_{OH})	- - - - -	-24 mA
Maximum low level output current (I_{OL})	- - - - -	48 mA

1.5 Digital logic testing for device classes Q and V.

Fault coverage measurement of manufacturing logic tests (MIL-STD-883, test method 5012) - - - - - XX percent 5/

- 1/ Stresses above the absolute maximum rating may cause permanent damage to the device. Extended operation at the maximum levels may degrade performance and affect reliability.
- 2/ Unless otherwise noted, all voltages are referenced to GND.
- 3/ The limits for the parameters specified herein shall apply over the full specified V_{CC} range and case temperature range of -55°C to +125°C.
- 4/ The input and output negative voltage ratings may be exceeded provided that the input and output clamp current ratings are observed.
- 5/ Values will be added when they become available.

STANDARDIZED MILITARY DRAWING DEFENSE ELECTRONICS SUPPLY CENTER DAYTON, OHIO 45444	SIZE A	5962-92147
	REVISION LEVEL	SHEET 3

2. APPLICABLE DOCUMENTS

2.1 Government specifications, standards, bulletin, and handbook. Unless otherwise specified, the following specifications, standards, bulletin, and handbook of the issue listed in that issue of the Department of Defense Index of Specifications and Standards specified in the solicitation, form a part of this drawing to the extent specified herein.

SPECIFICATIONS

MILITARY

- MIL-M-38510 - Microcircuits, General Specification for.
- MIL-I-38535 - Integrated Circuits, Manufacturing, General Specification for.

STANDARDS

MILITARY

- MIL-STD-480 - Configuration Control-Engineering Changes, Deviations and Waivers.
- MIL-STD-883 - Test Methods and Procedures for Microelectronics.
- MIL-STD-1835 - Microcircuit Case Outlines

BULLETIN

MILITARY

- MIL-BUL-103 - List of Standardized Military Drawings (SMD's).

HANDBOOK

MILITARY

- MIL-HDBK-780 - Standardized Military Drawings.

(Copies of the specifications, standards, bulletin, and handbook required by manufacturers in connection with specific acquisition functions should be obtained from the contracting activity or as directed by the contracting activity.)

2.2 Order of precedence. In the event of a conflict between the text of this drawing and the references cited herein, the text of this drawing shall take precedence.

3. REQUIREMENTS

3.1 Item requirements. The individual item requirements for device class M shall be in accordance with 1.2.1 of MIL-STD-883, "Provisions for the use of MIL-STD-883 in conjunction with compliant non-JAN devices" and as specified herein. The individual item requirements for device classes B and S shall be in accordance with MIL-M-38510 and as specified herein. The individual item requirements for device classes Q and V shall be in accordance with MIL-I-38535, the device manufacturer's Quality Management (QM) plan, and as specified herein.

3.2 Design, construction, and physical dimensions. The design, construction, and physical dimensions shall be as specified in MIL-M-38510 for device classes M, B, and S and MIL-I-38535 for device classes Q and V and herein.

3.2.1 Case outline. The case outline shall be in accordance with 1.2.4 herein.

3.2.2 Terminal connections. The terminal connections shall be as specified on figure 1.

3.2.3 Truth table. The truth table shall be as specified on figure 2.

3.2.4 Logic diagram. The logic diagram shall be as specified on figure 3.

3.2.5 Ground bounce waveforms and test circuit. The ground bounce load circuit and waveforms shall be as specified on figure 4.

3.2.6 Switching waveforms and test circuit. The switching waveforms and test circuit shall be as specified on figure 5.

STANDARDIZED MILITARY DRAWING DEFENSE ELECTRONICS SUPPLY CENTER DAYTON, OHIO 45444	SIZE A		5962-92147
		REVISION LEVEL	SHEET 4

3.3 Electrical performance characteristics and postirradiation parameter limits. Unless otherwise specified herein, the electrical performance characteristics and postirradiation parameter limits are as specified in table I and shall apply over the full case operating temperature range. Test conditions for these specified characteristics and limits are as specified in table I.

3.4 Electrical test requirements. The electrical test requirements shall be the subgroups specified in table II. The electrical tests for each subgroup are defined in table I.

3.5 Marking. The part shall be marked with the PIN listed in 1.2 herein. Marking for device class M shall be in accordance with MIL-STD-883 (see 3.1 herein). In addition, the manufacturer's PIN may also be marked as listed in MIL-BUL-103. Marking for device classes B and S shall be in accordance with MIL-M-38510. Marking for device classes Q and V shall be in accordance with MIL-I-38535.

3.5.1 Certification/compliance mark. The compliance mark for device class M shall be a "C" as required in MIL-STD-883 (see 3.1 herein). The certification mark for device classes B and S shall be a "J" or "JAN" as required in MIL-M-38510. The certification mark for device classes Q and V shall be a "QML" as required in MIL-I-38535.

3.6 Certificate of compliance. For device class M, a certificate of compliance shall be required from a manufacturer in order to be listed as an approved source of supply in MIL-BUL-103 (see 6.7.3 herein). For device classes Q and V, a certificate of compliance shall be required from a QML-38535 listed manufacturer in order to supply to the requirements of this drawing (see 6.7.2 herein). The certificate of compliance submitted to DESC-EC prior to listing as an approved source of supply for this drawing shall affirm that the manufacturer's product meets, for device class M the requirements of MIL-STD-883 (see 3.1 herein), or for device classes Q and V, the requirements of MIL-I-38535 and the requirements herein.

3.7 Certificate of conformance. A certificate of conformance as required for device class M in MIL-STD-883 (see 3.1 herein) or device classes B and S in MIL-M-38510 or for device classes Q and V in MIL-I-38535 shall be provided with each lot of microcircuits delivered to this drawing.

3.8 Notification of change for device class M. For device class M, notification to DESC-EC of change of product (see 6.2 herein) involving devices acquired to this drawing is required for any change as defined in MIL-STD-480.

3.9 Verification and review for device class M. For device class M, DESC, DESC's agent, and the acquiring activity retain the option to review the manufacturer's facility and applicable required documentation. Offshore documentation shall be made available onshore at the option of the reviewer.

3.10 Microcircuit group assignment for device classes M, B, and S. Device classes M, B, and S devices covered by this drawing shall be in microcircuit group number XX (see MIL-M-38510, appendix E).

3.11 Serialization for device class S. All device class S devices shall be serialized in accordance with MIL-M-38510.

STANDARDIZED MILITARY DRAWING DEFENSE ELECTRONICS SUPPLY CENTER DAYTON, OHIO 45444	SIZE A		5962-92147
		REVISION LEVEL	SHEET 5

TABLE I. Electrical performance characteristics.

Test and MIL-STD-883 test method 1/	Symbol	Test conditions 2/ -55°C ≤ T _c ≤ +125°C 4.5 V ≤ V _{CC} ≤ 5.5 V unless otherwise specified	Device type	V _{CC}	Group A subgroups	Limits 3/		Unit
						Min	Max	
High level output voltage 3006	V _{OH1}	For all inputs affecting output under test V _{IN} = 2.0 V or 0.8 V I _{OH} = -3 mA	All	4.5 V	1,2,3	2.5		V
	V _{OH2}	For all inputs affecting output under test V _{IN} = 2.0 V or 0.8 V I _{OH} = -3 mA	All	5.0 V	1,2,3	3.0		
	V _{OH3}	For all inputs affecting output under test V _{IN} = 2.0 V or 0.8 V I _{OH} = -24 mA	All	4.5 V	1,2,3	2.0		
Low level output voltage 3007	V _{OL}	For all inputs affecting output under test V _{IN} = 2.0 V or 0.8 V I _{OL} = 48 mA	All	4.5 V	1,2,3		0.55	V
Three-state output leakage current high 3021	I _{OZH} 4/ 5/	For control inputs affecting output under test V _{IN} = V _{IH} or V _{IL} V _{IH} = 2.0 V V _{IL} = 0.8 V V _{OUT} = 2.7 V	All	5.5 V	1,2,3		10.0	μA
Three-state output leakage current low 3020	I _{OZL} 4/ 5/	For control inputs affecting output under test V _{IN} = V _{IH} or V _{IL} V _{IH} = 2.0 V V _{IL} = 0.8 V V _{OUT} = 0.5 V	All	5.5 V	1,2,3		-10.0	μA
Negative input clamp voltage 3022	V _{IC-}	For input under test I _{IN} = -18 mA	All	4.5 V	1,2,3		-1.2	V
Off-state leakage current	I _{OFF}	For input or output under test V _{IN} or V _{OUT} = 4.5 V All other pins at 0.0 V	All	0.0 V	1		±100	μA
High-state leakage current	I _{CEX}	For output under test V _{OUT} = 5.5 V Outputs at high logic state	All	5.5 V	1,2,3		50	μA

See footnotes at end of table.

STANDARDIZED MILITARY DRAWING DEFENSE ELECTRONICS SUPPLY CENTER DAYTON, OHIO 45444	SIZE A		5962-92147
		REVISION LEVEL	SHEET 6

TABLE I. Electrical performance characteristics - continued.

Test and MIL-STD-883 test method 1/	Symbol	Test conditions 2/ -55°C ≤ T _c ≤ +125°C 4.5 V ≤ V _{CC} ≤ 5.5 V unless otherwise specified	Device type	V _{CC}	Group A subgroups	Limits 3/		Unit
						Min	Max	
Input current high 3010	I _{IH}	For input under test V _{IN} = V _{CC}	All	5.5 V	1,2,3		+1.0	μA
Input current low 3009	I _{IL}	For input under test V _{IN} = GND	All	5.5 V	1,2,3		-1.0	μA
Output current 3011	I _O 6/	V _{OUT} = 2.5 V	All	5.5 V	1,2,3	-50	-180	mA
Quiescent supply current delta TTL input levels 3005	ΔI _{CC} 7/	Data inputs Outputs enabled For input under test V _{IN} = 3.4 V For all other inputs V _{IN} = V _{CC} or GND	All	5.5 V	1,2,3		1.5	mA
		Data inputs Outputs disabled For input under test V _{IN} = 3.4 V For all other inputs V _{IN} = V _{CC} or GND	All	5.5 V	1,2,3		50.0	μA
		Control inputs For input under test V _{IN} = 3.4 V For all other inputs V _{IN} = V _{CC} or GND	All	5.5 V	1,2,3		1.5	mA
Quiescent supply current output high 3005	I _{CCH}	V _{IN} = V _{CC} or GND I _{OUT} = 0 A	All	5.5 V	1,2,3		250	μA
Quiescent supply current output low 3005	I _{CCL}	V _{IN} = V _{CC} or GND I _{OUT} = 0 A	All	5.5 V	1,2,3		30	mA
Quiescent supply current output three-state 3005	I _{CCZ}	V _{IN} = V _{CC} or GND I _{OUT} = 0 A	All	5.5 V	1,2,3		250	μA

See footnotes at end of table.

STANDARDIZED MILITARY DRAWING DEFENSE ELECTRONICS SUPPLY CENTER DAYTON, OHIO 45444	SIZE A		5962-92147
		REVISION LEVEL	SHEET 7

TABLE I. Electrical performance characteristics - continued.

Test and MIL-STD-883 test method 1/	Symbol	Test conditions 2/ -55°C ≤ T _C ≤ +125°C 4.5 V ≤ V _{CC} ≤ 5.5 V unless otherwise specified	Device type	V _{CC}	Group A subgroups	Limits 3/		Unit
						Min	Max	
Input capacitance 3012	C _{IN}	See 4.4.1b T _C = +25°C	All	5.0 V	4		11	pF
Output capacitance 3012	C _{OUT}	See 4.4.1b T _C = +25°C	All	5.0 V	4		16	pF
Low level ground bounce noise	V _{OLP} 8/	V _{IH} = 3.0 V V _{IL} = 0.0 V T _A = +25°C See figure 4	All	5.0 V	4		1200	mV
Low level ground bounce noise	V _{OLV} 8/		All	5.0 V	4		-1800	mV
High level V _{CC} bounce noise	V _{OHP} 8/		All	5.0 V	4		1500	mV
High level V _{CC} bounce noise	V _{OHV} 8/		All	5.0 V	4		-1100	mV
Functional test	9/		V _{IL} = 0.8 V V _{IH} = 2.0 V Verify output V _O See 4.4.1d	All	4.5 V	7,8	L	H
		All		5.5 V	7,8	L	H	
Propagation delay time, mA _N to mY _N 3003	t _{PLH} 10/	C _L = 50 pF minimum, R _L = 500Ω, See figure 5	All	5.0 V	9	1.0	4.1	ns
				4.5 V and 5.5 V	10,11	1.0	5.3	
Propagation delay time, mA _N to mY _N 3003	t _{PHL} 10/	C _L = 50 pF minimum, R _L = 500Ω, See figure 5	All	5.0 V	9	1.0	4.2	ns
				4.5 V and 5.5 V	10,11	1.0	5.0	

See footnotes at end of table.

STANDARDIZED MILITARY DRAWING DEFENSE ELECTRONICS SUPPLY CENTER DAYTON, OHIO 45444	SIZE A		5962-92147
		REVISION LEVEL	SHEET 8

TABLE I. Electrical performance characteristics - continued.

Test and MIL-STD-883 test method <u>1/</u>	Symbol	Test conditions <u>2/</u> -55°C ≤ T _C ≤ +125°C 4.5 V ≤ V _{CC} ≤ 5.5 V unless otherwise specified	Device type	V _{CC}	Group A subgroups	Limits <u>3/</u>		Unit
						Min	Max	
Propagation delay time, output enable, OEn to mYn 3003	t _{PZH} <u>10/</u>	C _L = 50 pF minimum, R _L = 500Ω, See figure 5	All	5.0 V	9	1.1	4.6	ns
				4.5 V and 5.5 V	10,11	0.8	5.7	
Propagation delay time, output enable, OEn to mYn 3003	t _{PZL} <u>10/</u>	C _L = 50 pF minimum, R _L = 500Ω, See figure 5	All	5.0 V	9	2.1	5.6	ns
				4.5 V and 5.5 V	10,11	1.2	7.9	
Propagation delay time, output disable, OEn to mYn 3003	t _{PHZ} <u>10/</u>	C _L = 50 pF minimum, R _L = 500Ω, See figure 5	All	5.0 V	9	2.1	5.6	ns
				4.5 V and 5.5 V	10,11	1.2	7.6	
Propagation delay time, output disable, OEn to mYn 3003	t _{PLZ} <u>10/</u>	C _L = 50 pF minimum, R _L = 500Ω, See figure 5	All	5.0 V	9	1.5	5.6	ns
				4.5 V and 5.5 V	10,11	1.0	7.9	

1/ For tests not listed in the referenced MIL-STD-883 (e.g. ΔI_{CC}), utilize the general test procedure of 883 under the conditions listed herein.

2/ Each input/output, as applicable shall be tested at the specified temperature, for the specified limits, to the tests in table I herein. Output terminals not designated shall be high level logic, low level logic, or open, except for all I_{CC} and ΔI_{CC} tests, where the output terminals shall be open. When performing these tests, the current meter shall be placed in the circuit such that all current flows through the meter. For input terminals not designated, V_{IN} = GND or V_{IN} ≥ 3.0 V.

3/ For negative and positive voltage and current values: The sign designates the potential difference in reference to GND and the direction of current flow respectively; and the absolute value of the magnitude, not the sign, is relative to the minimum and maximum limits, as applicable, listed herein. All devices shall meet or exceed the limits specified in table I at 4.5 V ≤ V_{CC} ≤ 5.5 V.

STANDARDIZED
MILITARY DRAWING
DEFENSE ELECTRONICS SUPPLY CENTER
DAYTON, OHIO 45444

SIZE
A

5962-92147

REVISION LEVEL

SHEET

9

- 4/ This test shall be guaranteed, if not tested, to the limits specified in table I herein, when performed with control inputs that affect the state of the output under test at $V_{IN} = 0.8 \text{ V}$ or 2.0 V .
- 5/ Due to tester limitations, this test may be performed at $V_{IH} = 3.0 \text{ V}$ but shall be guaranteed at $V_{IH} = 2.0 \text{ V}$.
- 6/ Not more than one output should be tested at one time, and the duration of the test condition should not exceed one second.
- 7/ This test may be performed either one input at a time (preferred method) or with all input pins simultaneously at $V_{IN} = V_{CC} - 2.1 \text{ V}$ (alternate method). Classes B, S, Q, and V shall use the preferred method. When the test is performed using the alternate test method the maximum limit is equal to the number of inputs at a high TTL input level times $50 \mu\text{A}$ or 1.5 mA , as applicable, and the preferred method and limits are guaranteed.
- 8/ This test is for qualification only. Ground and V_{CC} bounce tests are performed on a non-switching (quiescent) output and are used to measure the magnitude of induced noise caused by other simultaneously switching outputs. The test is performed on a low noise bench test fixture. For the device under test, all outputs shall be loaded with 500Ω of load resistance and a minimum of 50 pF of load capacitance (see figure 4). Only chip capacitors and resistors shall be used. The output load components shall be located as close as possible to the device outputs. It is suggested, that whenever possible, this distance be kept to less than 0.25 inches. Decoupling capacitors shall be placed in parallel from V_{CC} to ground. The values of these decoupling capacitors shall be determined by the device manufacturer. The low and high level ground and V_{CC} bounce noise is measured at the quiet output using a 1 GHz minimum bandwidth oscilloscope with a 50Ω input impedance.
- The device inputs shall be conditioned such that all outputs are at a high nominal V_{OH} level. The device inputs shall then be conditioned such that they switch simultaneously and the output under test remains at V_{OH} as all other outputs possible are switched from V_{OH} to V_{OL} . V_{OHV} and V_{OHP} are then measured from the nominal V_{OH} level to the largest negative and positive peaks, respectively (see figure 4). This is then repeated with the same outputs not under test switching from V_{OL} to V_{OH} .
- The device inputs shall be conditioned such that all outputs are at a low nominal V_{OL} level. The device inputs shall then be conditioned such that they switch simultaneously and the output under test remains at V_{OL} as all other outputs possible are switched from V_{OL} to V_{OH} . V_{OLP} and V_{OLV} are then measured from the nominal V_{OL} level to the largest positive and negative peaks, respectively (see figure 4). This is then repeated with the same outputs not under test switching from V_{OH} to V_{OL} .
- 9/ Tests shall be performed in sequence, attributes data only. Functional tests shall include the truth table and other logic patterns used for fault detection. The test vectors used to verify the truth table shall, at a minimum, test all functions of each input and output. All possible input to output logic patterns per function shall be guaranteed, if not tested, to the truth table in figure 2, herein. Functional tests shall be performed in sequence as approved by the qualifying activity on qualified devices. After incorporating allowable tolerances per MIL-STD-883, $V_{IL} = 0.4 \text{ V}$ and $V_{IH} = 2.4 \text{ V}$. For outputs, $L \leq 0.8 \text{ V}$, $H \geq 2.0 \text{ V}$.
- 10/ For propagation delay tests, all paths must be tested.

STANDARDIZED MILITARY DRAWING DEFENSE ELECTRONICS SUPPLY CENTER DAYTON, OHIO 45444	SIZE A		5962-92147
		REVISION LEVEL	SHEET 10

Device type	01
Case outlines	R,S,2
Terminal number	Terminal symbol
1	$\overline{OE1}$
2	1A1
3	2Y4
4	1A2
5	2Y3
6	1A3
7	2Y2
8	1A4
9	2Y1
10	GND
11	2A1
12	1Y4
13	2A2
14	1Y3
15	2A3
16	1Y2
17	2A4
18	1Y1
19	OE2
20	V _{CC}

Pin descriptions	
Terminal symbol	Description
mAn (m = 1 to 4, n = 1 to 2)	Data inputs
$\overline{OE_n}$ (n = 1 to 2)	Output enable controls
mYn (m = 1 to 4, n = 1 to 2)	Outputs (non-inverting)

FIGURE 1. Terminal connections.

Device type 01		
Inputs		Output Y
$\overline{OE_n}$	mAn	
L	H	H
L	L	L
H	X	Z

H = High voltage level
L = Low voltage level
X = Irrelevant
Z = Disabled

FIGURE 2. Truth table.

STANDARDIZED MILITARY DRAWING DEFENSE ELECTRONICS SUPPLY CENTER DAYTON, OHIO 45444	SIZE A		5962-92147
		REVISION LEVEL	SHEET 11

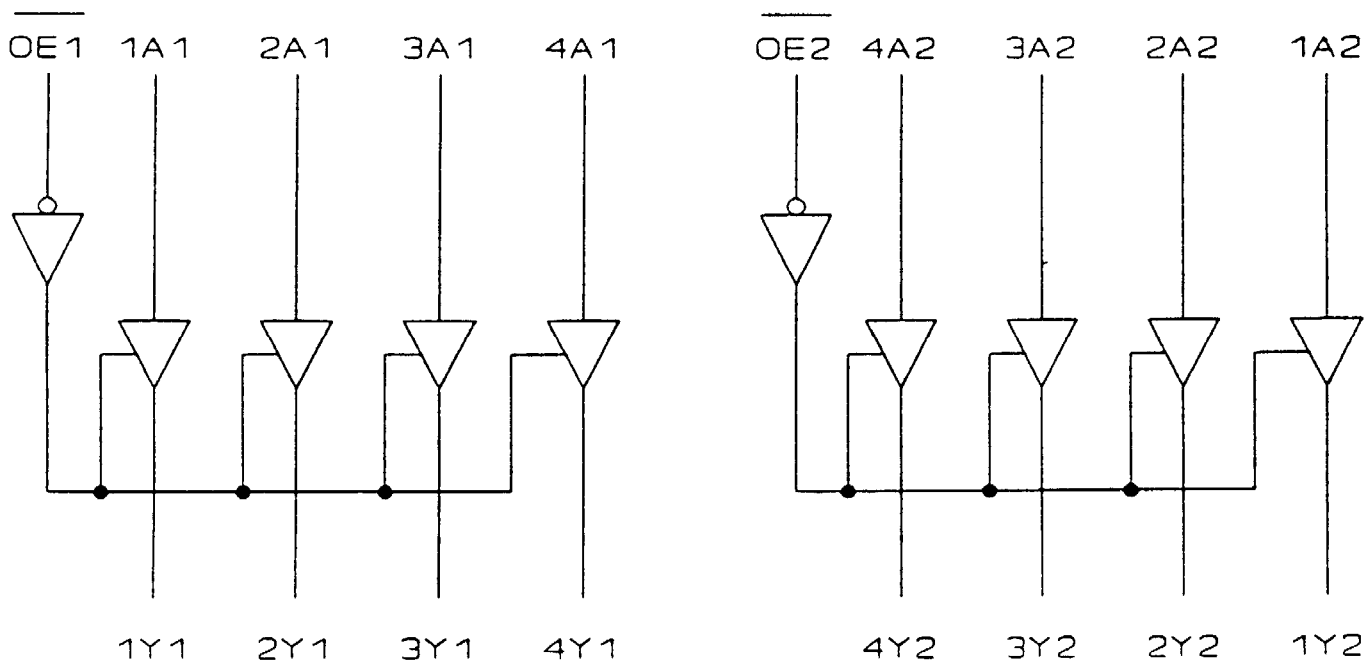

FIGURE 3. Logic diagram.

STANDARDIZED
MILITARY DRAWING
DEFENSE ELECTRONICS SUPPLY CENTER
DAYTON, OHIO 45444

SIZE
A

5962-92147

REVISION LEVEL

SHEET

12

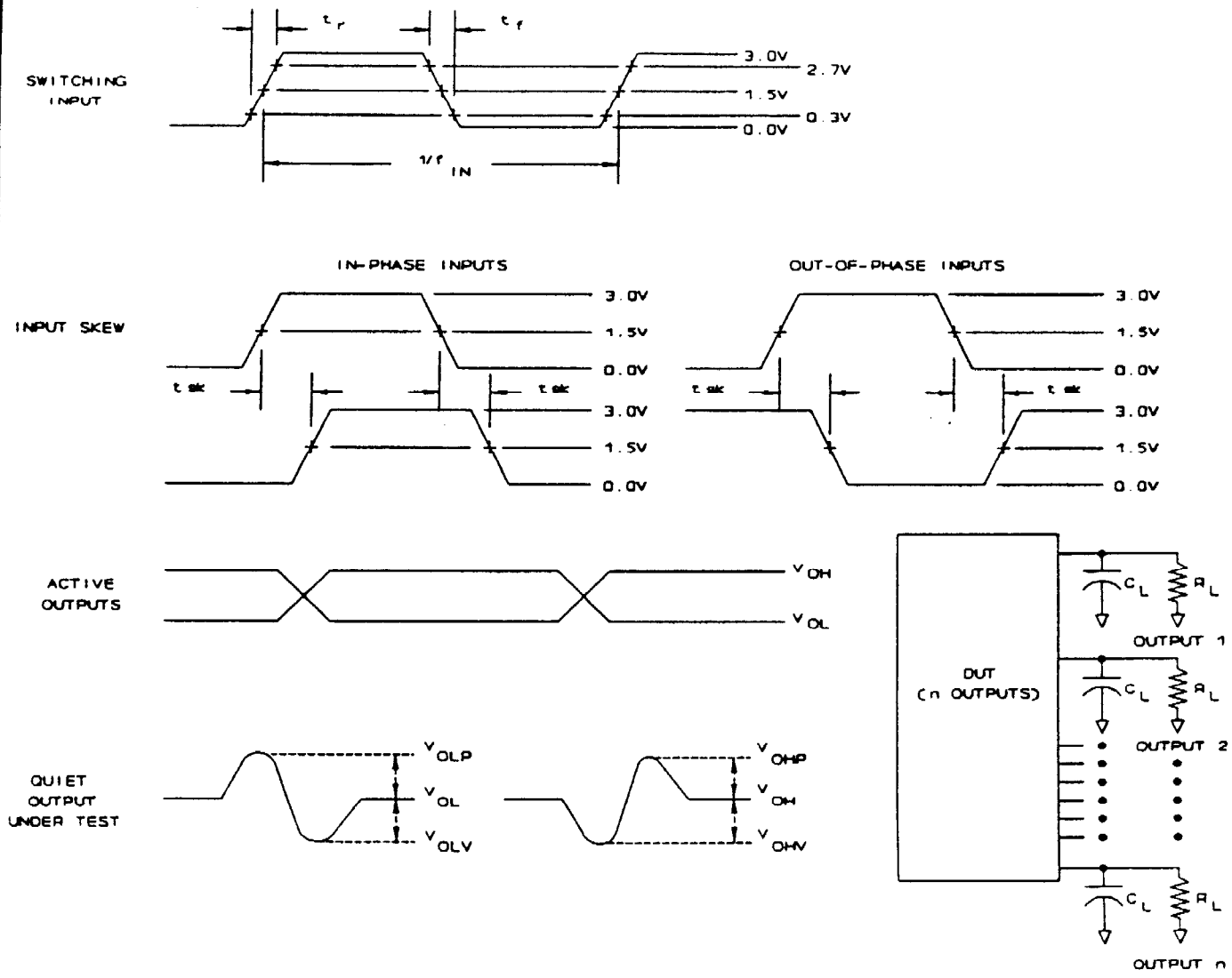

- NOTES:**
1. C_L includes a 47 pF chip capacitor (-0 percent, +20 percent) and at least 3 pF of equivalent capacitance from the test jig and probe.
 2. $R_L = 450\Omega \pm 1$ percent, chip resistor in series with a 50 Ω termination. For monitored outputs, the 50 Ω termination shall be the 50 Ω characteristic impedance of the coaxial connector to the oscilloscope.
 3. Input signal to the device under test:
 - a. $V_{IN} = 0.0$ V to 3.0 V; duty cycle = 50 percent; $f_{IN} \geq 1$ MHz.
 - b. $t_r, t_f = 3$ ns ± 1.0 ns. For input signal generators incapable of maintaining these values of t_r and t_f , the 3.0 ns limit may be increased up to 10 ns, as needed, maintaining the ± 1.0 ns tolerance and guaranteeing the results at 3.0 ns ± 1.0 ns; skew between any two switching inputs signals (t_{sk}): ≤ 250 ps.

FIGURE 4. Ground bounce load circuit and waveforms.

STANDARDIZED MILITARY DRAWING DEFENSE ELECTRONICS SUPPLY CENTER DAYTON, OHIO 45444	SIZE A		5962-92147
		REVISION LEVEL	SHEET 13

The shaded areas indicate when the input is permitted to change for predictable output performance.

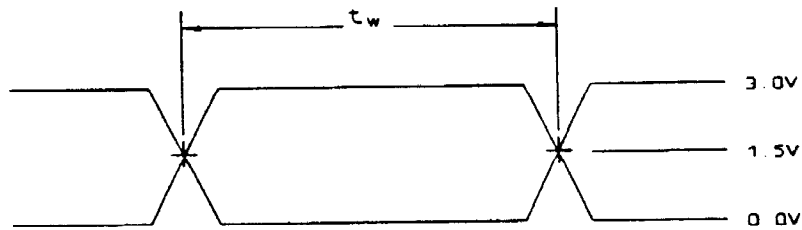
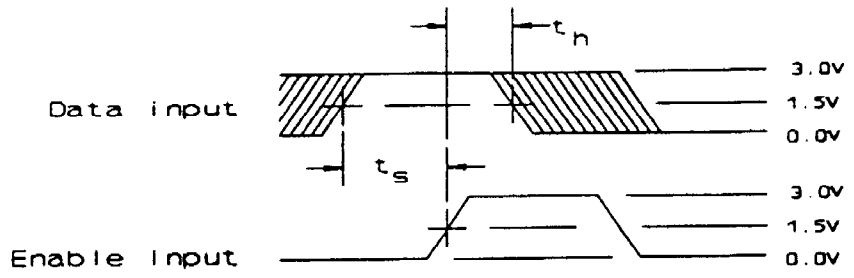
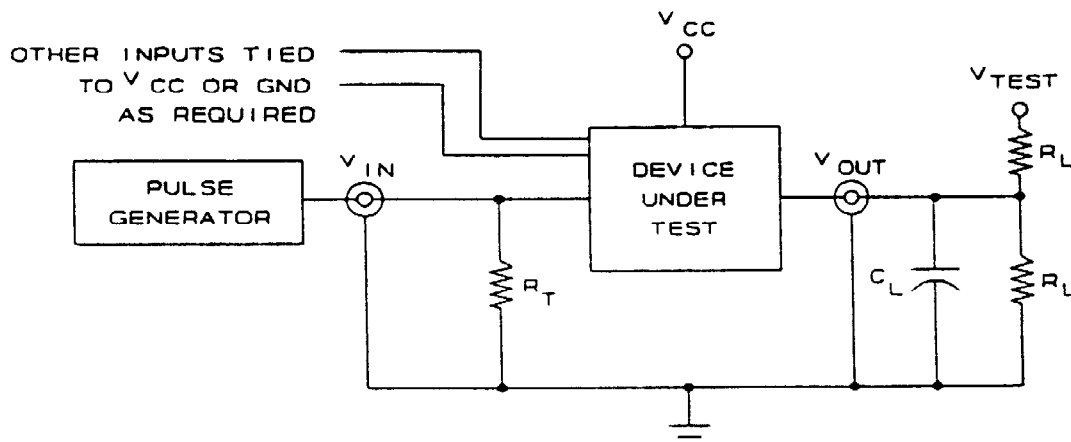
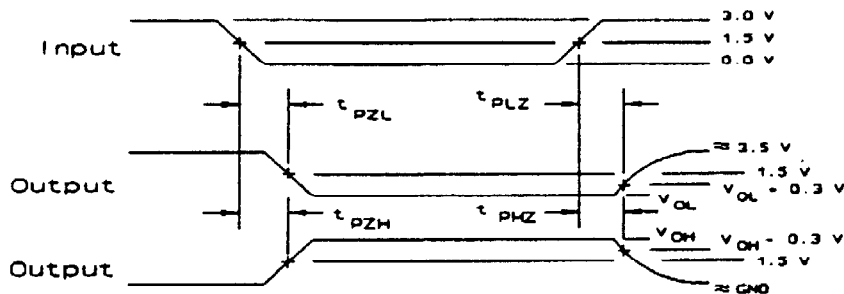
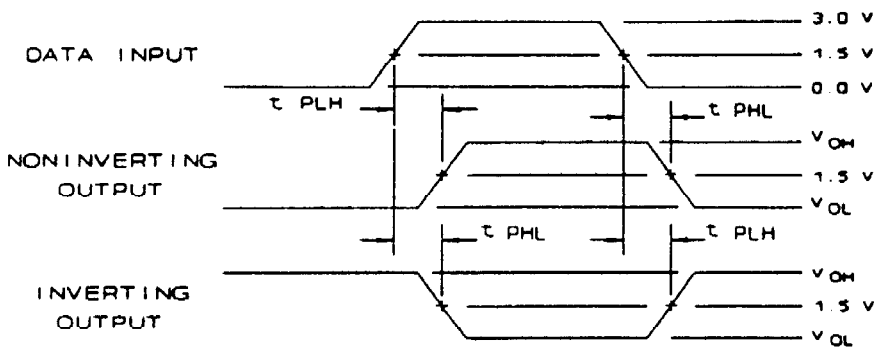

FIGURE 5. Switching waveforms and test circuit.

STANDARDIZED MILITARY DRAWING DEFENSE ELECTRONICS SUPPLY CENTER DAYTON, OHIO 45444	SIZE A		5962-92147
		REVISION LEVEL	SHEET 14



NOTES:

1. When measuring t_{PLZ} and t_{PZL} : $V_{TEST} = 7.0 \text{ V}$.
2. When measuring t_{PHZ} , t_{PZH} , t_{PLH} and t_{PHL} : $V_{TEST} = \text{open}$.
3. The t_{PZL} and t_{PLZ} reference waveform is for the output under test with internal conditions such that the output is at V_{OL} except when disabled by the output enable control. The t_{PZH} and t_{PHZ} reference waveform is for the output under test with internal conditions such that the output is at V_{OH} except when disabled by the output enable control.
4. $C_L = 50 \text{ pF}$ minimum or equivalent (includes test jig and probe capacitance).
5. $R_L = 500\Omega$ or equivalent.
6. $R_T = 50\Omega$ or equivalent.
7. Input signal from pulse generator: $V_{IN} = 0.0 \text{ V}$ to 3.0 V ; $\text{PRR} \leq 10 \text{ MHz}$; $t_r \leq 2.5 \text{ ns}$; $t_f \leq 2.5 \text{ ns}$; t_r and t_f shall be measured from 0.3 to 2.7 V and 2.7 V to 0.3 V , respectively; duty cycle = 50 percent.
8. Timing parameters shall be tested at a minimum input frequency of 1 MHz.
9. The outputs are measured one at a time with one transition per measurement.

FIGURE 5. Switching waveforms and test circuit - Continued.

STANDARDIZED MILITARY DRAWING DEFENSE ELECTRONICS SUPPLY CENTER DAYTON, OHIO 45444	SIZE A		5962-92147
		REVISION LEVEL	SHEET 15

4. QUALITY ASSURANCE PROVISIONS

4.1 Sampling and inspection. For device class M, sampling and inspection procedures shall be in accordance with section 4 of MIL-M-38510 to the extent specified in MIL-STD-883 (see 3.1 herein). For device class B, sampling and inspection procedures shall be in accordance with MIL-M-38510 and method 5005 of MIL-STD-883, except as modified herein. For device class S, sampling and inspection procedures shall be in accordance with MIL-M-38510, and methods 5005 and 5007 of MIL-STD-883, except as modified herein. For device classes Q and V, sampling and inspection procedures shall be in accordance with MIL-I-38535 and the device manufacturer's QM plan.

4.2 Screening. For device class M, screening shall be in accordance with method 5004 of MIL-STD-883, and shall be conducted on all devices prior to quality conformance inspection. For device classes B and S, screening shall be in accordance with method 5004 of MIL-STD-883, and shall be conducted on all devices prior to qualification and quality conformance inspection. For device classes Q and V, screening shall be in accordance with MIL-I-38535, and shall be conducted on all devices prior to qualification and technology conformance inspection. The following additional criteria shall apply.

4.2.1 Additional criteria for device classes M, B, and S.

a. Burn-in test, method 1015 of MIL-STD-883.

- (1) Test condition A, B, C or D. For device class M, the test circuit shall be maintained by the manufacturer under document revision level control and shall be made available to the preparing or acquiring activity upon request. For device classes B and S, the test circuit shall be submitted to the qualifying activity. For device classes M, B, and S, the test circuit shall specify the inputs, outputs, biases, and power dissipation, as applicable, in accordance with the intent specified in test method 1015.
- (2) $T_A = +125^\circ\text{C}$, minimum.
- (3) For device class M, unless otherwise noted, the requirements for device class B in method 1015 of MIL-STD-883 shall be followed.

4.2.2 Additional criteria for device classes Q and V.

- a. The burn-in test duration, test condition and test temperature, or approved alternatives shall be as specified in the device manufacturer's QM plan in accordance with MIL-I-38535. The burn-in test circuit shall be maintained under document revision level control of the device manufacturer's Technology Review Board (TRB) in accordance with MIL-I-38535 and shall be made available to the preparing or acquiring activity upon request. The test circuit shall specify the inputs, outputs, biases, and power dissipation, as applicable, in accordance with the intent specified in test method 1015.
- b. Interim and final electrical test parameters shall be as specified in table II herein.
- c. Additional screening for device class V beyond the requirements of device class Q shall be as specified in appendix B of MIL-I-38535.

4.3 Qualification inspection.

4.3.1 Qualification inspection for device classes B and S. Qualification inspection for device classes B and S shall be in accordance with MIL-M-38510. Inspections to be performed shall be those specified in method 5005 of MIL-STD-883 and herein for groups A, B, C, D, and E inspections (see 4.4.1 through 4.4.5).

4.3.2 Qualification inspection for device classes Q and V. Qualification inspection for device classes Q and V shall be in accordance with MIL-I-38535. Inspections to be performed shall be those specified in MIL-I-38535 and herein for groups A, B, C, D, and E inspections (see 4.4.1 through 4.4.5).

STANDARDIZED MILITARY DRAWING DEFENSE ELECTRONICS SUPPLY CENTER DAYTON, OHIO 45444	SIZE A		5962-92147
		REVISION LEVEL	SHEET 16

TABLE II. Electrical test requirements.

Test requirements	Subgroups (in accordance with MIL-STD-883, method 5005, table I)			Subgroups (in accordance with MIL-I-38535, table III)	
	Device class M	Device class B	Device class S	Device class Q	Device class V
Interim electrical parameters (see 4.2)		1	1	1	1
Final electrical parameters (see 4.2)	<u>1/</u> 1,2,3 7,8,9,10,11	<u>1/</u> 1,2,3, 7,8,9,10,11	<u>2/</u> 1,2,3, 7,8,9,10,11	<u>1/</u> 1,2,3 7,8,9,10,11	<u>2/</u> 1,2,3 7,8,9,10,11
Group A test requirements (see 4.4)	1,2,3,4,7, 8,9,10,11	1,2,3,4,7, 8,9,10,11	1,2,3,4,7, 8,9,10,11	1,2,3,4,7, 8,9,10,11	1,2,3,4,7, 8,9,10,11
Group B end-point electrical parameters (see 4.4)			1,2,3,7,8, 9,10,11		
Group C end-point electrical parameters (see 4.4)	1,2,3	1,2,3		1,2,3	1,2,3
Group D end-point electrical parameters (see 4.4)	1,2,3	1,2,3	1,2,3	1,2,3	1,2,3
Group E end-point electrical parameters (see 4.4)	1,7,9	1,7,9	1,7,9	1,7,9	1,7,9

1/ PDA applies to subgroup 1.

2/ PDA applies to subgroups 1 and 7.

4.3.3 Electrostatic discharge sensitivity qualification inspection. Electrostatic discharge sensitivity (ESDS) testing shall be performed in accordance with MIL-STD-883, method 3015. ESDS testing shall be measured only for initial qualification and after process or design changes which may affect ESDS classification.

4.4 Conformance inspection. Quality conformance inspection for device class M shall be in accordance with MIL-STD-883 (see 3.1 herein) and as specified herein. Quality conformance inspection for device classes B and S shall be in accordance with MIL-M-38510 and as specified herein. Inspections to be performed for device classes M, B, and S shall be those specified in method 5005 of MIL-STD-883 and herein for groups A, B, C, D, and E inspections (see 4.4.1 through 4.4.5). Technology conformance inspection for classes Q and V shall be in accordance with MIL-I-38535 including groups A, B, C, D, and E inspections and as specified herein except where option 2 of MIL-I-38535 permits alternate in-line control testing.

4.4.1 Group A inspection.

a. Tests shall be as specified in table II herein.

b. C_{IN} and C_{OUT} shall be measured only for initial qualification and after process or design changes which may affect capacitance. C_{IN} and C_{OUT} shall be measured between the designated terminal and GND at a frequency of 1 MHz. This test may be performed at 10 MHz and guaranteed, if not tested, at 1 MHz. The DC bias for the pin under test (V_{BIAS}) = 2.5 V or 3.0 V. For C_{IN} and C_{OUT} , test all applicable pins on three devices with zero failures.

STANDARDIZED
MILITARY DRAWING
DEFENSE ELECTRONICS SUPPLY CENTER
DAYTON, OHIO 45444

SIZE
A

5962-92147

REVISION LEVEL

SHEET

17

c. Ground and V_{CC} bounce tests are required for all device classes. These tests shall be performed only for initial qualification, after process or design changes which may affect the performance of the device, and any changes to the test fixture. V_{OLP} , V_{OLV} , V_{OHP} , and V_{OHV} shall be measured for the worst case outputs of the device. All other outputs shall be guaranteed, if not tested to limits established for the worst case outputs. The worst case outputs tested are to be determined by the manufacturer. Test 5 devices assembled in the worst case package type supplied to this document. All other package types shall be guaranteed, if not tested to limits established for the worst case package. The package type to be tested shall be determined by the manufacturer. The device manufacturer will submit to DESC-EC data that shall include, all measured peak values for each device tested and detailed oscilloscope plots for each V_{OLP} , V_{OLV} , V_{OHP} , and V_{OHV} from one sample part per function. The plot shall contain the waveforms of both a switching output and the output under test.

Each device manufacturer shall test product on the fixtures they currently use. When a new fixture is used, the device manufacturer shall inform DESC-EC of this change and test the 5 devices on both the new and old test fixtures. The device manufacturer shall then submit to DESC-EC data from testing on both fixtures, that shall include, all measured peak values for each device tested and detailed oscilloscope plots for each V_{OLP} , V_{OLV} , V_{OHP} , and V_{OHV} from one sample part per function. The plot shall contain the waveforms of both a switching output and the output under test."

d. For device class M, subgroups 7 and 8 tests shall be sufficient to verify the truth table in figure 2 herein. The test vectors used to verify the truth table shall, at a minimum, test all functions of each input and output. All possible input to output logic patterns per function shall be guaranteed, if not tested, to the truth table in figure 2, herein. For device classes B and S, subgroups 7 and 8 tests shall be sufficient to verify the truth table as approved by the qualifying activity. For device classes Q and V, subgroups 7 and 8 shall include verifying the functionality of the device; these tests shall have been fault graded in accordance with MIL-STD-883, test method 5012 (see 1.5 herein).

4.4.2 Group B inspection. The group B inspection end-point electrical parameters shall be as specified in table II herein. Class S steady-state life (accelerated) shall be conducted using test condition D of method 1005 of MIL-STD-883. For device class S steady-state life tests, the test circuit shall be submitted to the qualifying activity.

4.4.3 Group C inspection. The group C inspection end-point electrical parameters shall be as specified in table II herein.

4.4.3.1 Additional criteria for device classes M and B. Steady-state life test conditions, method 1005 of MIL-STD-883:

a. Test condition A, B, C or D. For device class M, the test circuit shall be maintained by the manufacturer under document revision level control and shall be made available to the preparing or acquiring activity upon request. For device class B, the test circuit shall be submitted to the qualifying activity. For device classes M and B, the test circuit shall specify the inputs, outputs, biases, and power dissipation, as applicable, in accordance with the intent specified in test method 1015.

b. $T_A = +125^\circ\text{C}$, minimum.

c. Test duration: 1,000 hours, except as permitted by method 1005 of MIL-STD-883.

4.4.3.2 Additional criteria for device classes Q and V. The steady-state life test duration, test condition and test temperature, or approved alternatives shall be as specified in the device manufacturer's QM plan in accordance with MIL-I-38535. The burn-in test circuit shall be maintained under document revision level control of the device manufacturer's TRB in accordance with MIL-I-38535 and shall be made available to the preparing or acquiring activity upon request. The test circuit shall specify the inputs, outputs, biases, and power dissipation, as applicable, in accordance with the intent specified in test method 1015.

4.4.4 Group D inspection. Group D inspection shall be in accordance with table IV of method 5005 of MIL-STD-883. End-point electrical parameters shall be as specified in table II herein.

STANDARDIZED MILITARY DRAWING DEFENSE ELECTRONICS SUPPLY CENTER DAYTON, OHIO 45444	SIZE A		5962-92147
		REVISION LEVEL	SHEET 18

4.4.5 Group E inspection. Group E inspection is required only for parts intended to be marked as radiation hardness assured (see 3.5 herein). RHA levels for device classes B, S, Q, and V shall be M, D, R, and H and for device class M shall be M and D.

- a. End-point electrical parameters shall be as specified in table II herein.
- b. For device classes M, B, and S, the devices shall be subjected to radiation hardness assured tests as specified in MIL-M-38510 for the RHA level being tested. For device classes Q and V, the devices or test vehicle shall be subjected to radiation hardness assured tests as specified in MIL-M-38535 for the RHA level being tested. All device classes must meet the postirradiation end-point electrical parameter limits as specified in table I at $T_A = +25^\circ\text{C}$, after exposure, to the subgroups specified in table II herein.
- c. When specified in the purchase order or contract, a copy of the RHA delta limits shall be supplied.

4.5 Methods of inspection. Methods of inspection shall be specified as follows:

4.5.1 Voltage and current. Unless otherwise specified, all voltages given are referenced to the microcircuit GND terminal. Currents given are conventional current and positive when flowing into the referenced terminal.

5. PACKAGING

5.1 Packaging requirements. The requirements for packaging shall be in accordance with MIL-M-38510 for device classes M, B, and S and MIL-I-38535 for device classes Q and V.

6. NOTES

6.1 Intended use. Microcircuits conforming to this drawing are intended for use for Government microcircuit applications (original equipment), design applications, and logistics purposes.

6.1.1 Replaceability. Microcircuits covered by this drawing will replace the same generic device covered by a contractor-prepared specification or drawing.

6.1.2 Substitutability. Device classes B and Q devices will replace device class M devices.

6.2 Configuration control of SMD's. All proposed changes to existing SMD's will be coordinated with the users of record for the individual documents. This coordination will be accomplished in accordance with MIL-STD-481 using DD Form 1693, Engineering Change Proposal (Short Form).

6.3 Record of users. Military and industrial users shall inform Defense Electronics Supply Center when a system application requires configuration control and which SMD's are applicable to that system. DESC will maintain a record of users and this list will be used for coordination and distribution of changes to the drawings. Users of drawings covering microelectronic devices (FSC 5962) should contact DESC-EC, telephone (513) 296-6047.

6.4 Comments. Comments on this drawing should be directed to DESC-EC, Dayton, Ohio 45444, or telephone (513) 296-5377.

6.5 Abbreviations, symbols, and definitions. The abbreviations, symbols, and definitions used herein are defined in MIL-M-38510 and MIL-STD-1331, and as follows:

- GND - - - - - Ground zero voltage potential.
- I_{CC} - - - - - Quiescent supply current.
- I_{IL} - - - - - Input current low.
- I_{IH} - - - - - Input current high.
- T_C - - - - - Case temperature.
- T_A - - - - - Ambient temperature.
- V_{CC} - - - - - Positive supply voltage.
- C_{IN} - - - - - Input terminal-to-GND capacitance.
- V_{IC-} - - - - - Negative input clamp voltage.

STANDARDIZED MILITARY DRAWING DEFENSE ELECTRONICS SUPPLY CENTER DAYTON, OHIO 45444	SIZE A		5962-92147
		REVISION LEVEL	SHEET 19

6.6 One part - one part number system. The one part - one part number system described below has been developed to allow for transitions between identical generic devices covered by the four major microcircuit requirements documents (MIL-M-38510, MIL-H-38534, MIL-I-38535, and 1.2.1 of MIL-STD-883) without the necessity for the generation of unique PIN's. The four military requirements documents represent different class levels, and previously when a device manufacturer upgraded military product from one class level to another, the benefits of the upgraded product were unavailable to the Original Equipment Manufacturer (OEM), that was contractually locked into the original unique PIN. By establishing a one part number system covering all four documents, the OEM can acquire to the highest class level available for a given generic device to meet system needs without modifying the original contract parts selection criteria.

<u>Military documentation format</u>	<u>Example PIN under new system</u>	<u>Manufacturing source listing</u>	<u>Document listing</u>
New MIL-M-38510 Military Detail Specifications (in the SMD format)	5962-XXXXZZ(B or S)YY	QPL-38510 (Part 1 or 2)	MIL-BUL-103
New MIL-H-38534 Standardized Military Drawings	5962-XXXXZZ(H or K)YY	QML-38534	MIL-BUL-103
New MIL-I-38535 Standardized Military Drawings	5962-XXXXZZ(Q or V)YY	QML-38535	MIL-BUL-103
New 1.2.1 of MIL-STD-883 Standardized Military Drawings.	5962-XXXXZZ(M)YY	MIL-BUL-103	MIL-BUL-103

6.7 Sources of supply.

6.7.1 Sources of supply for device classes B and S. Sources of supply for device classes B and S are listed in QPL-38510.

6.7.2 Sources of supply for device classes Q and V. Sources of supply for device classes Q and V are listed in QML-38535. The vendors listed in QML-38535 have submitted a certificate of compliance (see 3.6 herein) to DESC-EC and have agreed to this drawing.

6.7.3 Approved sources of supply for device class M. Approved sources of supply for class M are listed in MIL-BUL-103. The vendors listed in MIL-BUL-103 have agreed to this drawing and a certificate of compliance (see 3.6 herein) has been submitted to and accepted by DESC-EC.

STANDARDIZED MILITARY DRAWING DEFENSE ELECTRONICS SUPPLY CENTER DAYTON, OHIO 45444	SIZE A		5962-92147
		REVISION LEVEL	SHEET 20

STANDARDIZED MILITARY DRAWING SOURCE APPROVAL BULLETIN

DATE:93-08-11

Approved sources of supply for SMD 5962-92147 are listed below for immediate acquisition only and shall be added to MIL-BUL-103 during the next revision. MIL-BUL-103 will be revised to include the addition or deletion of sources. The vendors listed below have agreed to this drawing and a certificate of compliance has been submitted to and accepted by DESC-EC. This bulletin is superseded by the next dated revision of MIL-BUL-103.

Standardized military drawing PIN	Vendor CAGE number	Vendor similar PIN 1/
5962-9214701MRX	01295 18324	SNJ54ABT244J 54ABT244/BRA
5962-9214701MSX	01295 18324	SNJ54ABT244W 54ABT244/BSA
5962-9214701M2X	01295 18324	SNJ54ABT244FK 54ABT244/B2A

1/ Caution. Do not use this number for item acquisition. Items acquired to this number may not satisfy the performance requirements of this drawing.

Vendor CAGE number

Vendor name and address

01295

Texas Instruments Incorporated
13500 N. Central Expressway
P.O. Box 655303
Dallas, TX 75265
Point of contact: I-20 at FM 1788
Midland, TX 79711-0448

18324

Philips Semiconductor
830 Stewart Dr.
Sunnyvale, CA 94088
Point of contact: 811 E. Arques Ave.
P.O. Box 3409
Sunnyvale, CA 94088-3409

The information contained herein is disseminated for convenience only and the Government assumes no liability whatsoever for any inaccuracies in the information bulletin.