

SN54155, SN54156, SN54LS155A, SN54LS156, SN74155, SN74156, SN74LS155A, SN74LS156 DUAL 2-LINE TO 4-LINE DECODERS/DEMULTIPLEXERS

MARCH 1974 — REVISED MARCH 1988

- **Applications:**
Dual 2-to 4-Line Decoder
Dual 1-to 4-Line Demultiplexer
3-to 8-Line Decoder
1-to 8-Line Demultiplexer
- **Individual Strobes Simplify Cascading for Decoding or Demultiplexing Larger Words**
- **Input Clamping Diodes Simplify System Design**
- **Choice of Outputs:**
Totem Pole ('155, 'LS155A)
Open-Collector ('156, 'LS156)

SN54155, SN54156, SN54LS155A,
SN54LS156 . . . J OR W PACKAGE
SN74155, SN74156 . . . N PACKAGE
SN74LS155A, SN74LS156 . . . D OR N PACKAGE
(TOP VIEW)

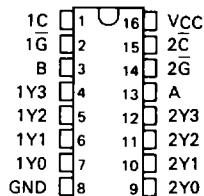

TYPES	TYPICAL AVERAGE PROPAGATION DELAY 3 GATE LEVELS	TYPICAL POWER DISSIPATION
'155, '156	21 ns	125 mW
'LS155A	18 ns	31 mW
'LS156	32 ns	31 mW

SN54LS155A, SN54LS156 . . . FK PACKAGE
(TOP VIEW)

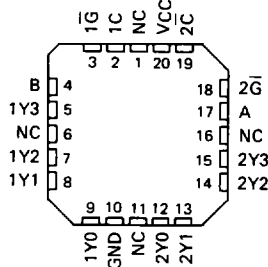

NC - No internal connection

description

These monolithic transistor-transistor-logic (TTL) circuits feature dual 1-line-to-4-line demultiplexers with individual strobes and common binary-address inputs in a single 16-pin package. When both sections are enabled by the strobes, the common binary-address inputs sequentially select and route associated input data to the appropriate output of each section. The individual strobes permit activating or inhibiting each of the 4-bit sections as desired. Data applied to input 1C is inverted at its outputs and data applied at 2C is not inverted through its outputs. The inverter following the 1C data input permits use as a 3-to-8-line decoder or 1-to-8-line demultiplexer without external gating. Input clamping diodes are provided on all of these circuits to minimize transmission-line effects and simplify system design.

logic symbols (2-line to 4-line decoder)†

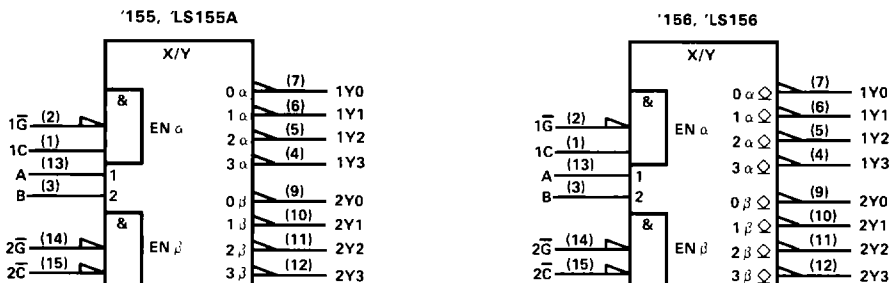

†These symbols are in accordance with ANSI/IEEE Std. 91-1984 and IEC Publication 617-12. For alternative symbols for other applications, see the following page.

Pin numbers shown are for D, J, N, and W packages

PRODUCTION DATA documents contain information current as of publication date. Products conform to specifications per the terms of Texas Instruments standard warranty. Production processing does not necessarily include testing of all parameters.

TEXAS
INSTRUMENTS

POST OFFICE BOX 655012 • DALLAS, TEXAS 75265

**SN54155, SN54156, SN54LS155A, SN54LS156,
SN74155, SN74156, SN74LS155A, SN74LS156
DUAL 2-LINE TO 4-LINE DECODERS/DEMULTIPLEXERS**

additional logic symbols (alternatives)†

2

TTL Devices

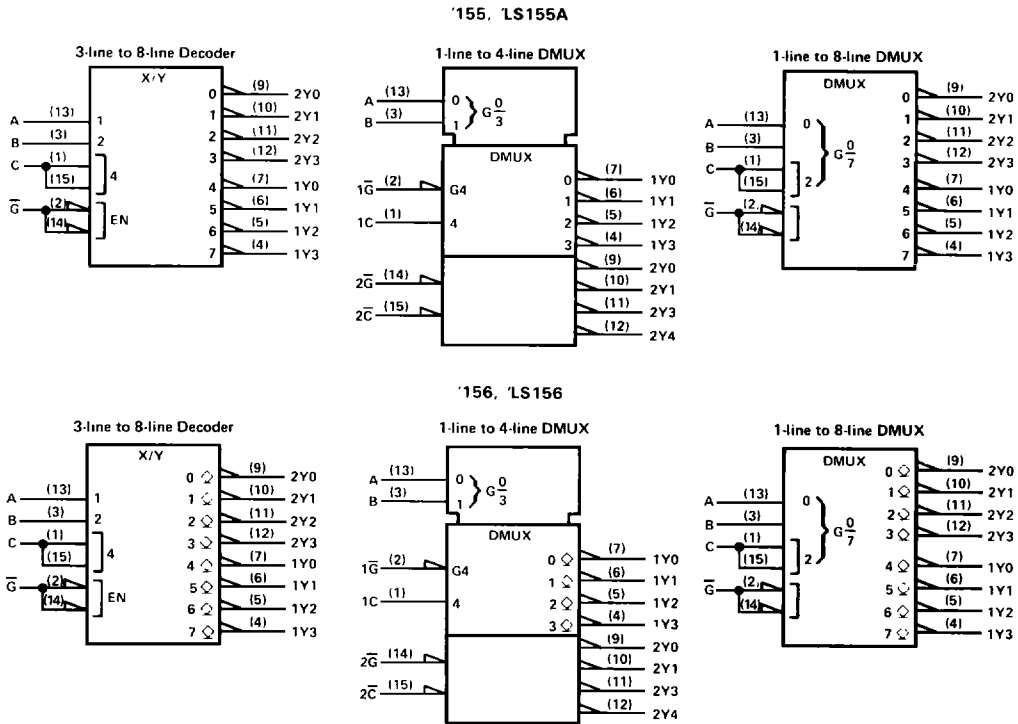

†These symbols are in accordance with ANSI/IEEE Std 91-1984 and IEC Publication 617-12. Pin numbers shown are for D, J, N, and W packages

schematics of inputs and outputs

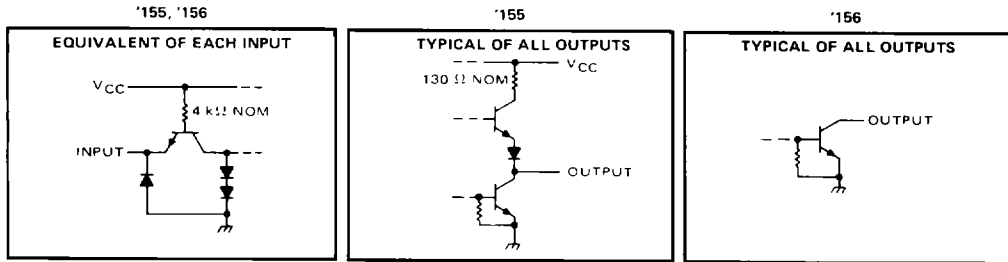

SN54155, SN54156, SN54LS155A, SN54LS156, SN74155, SN74156, SN74LS155A, SN74LS156 DUAL 2-LINE TO 4-LINE DECODERS/DEMULTIPLEXERS

schematics of inputs and outputs (continued)

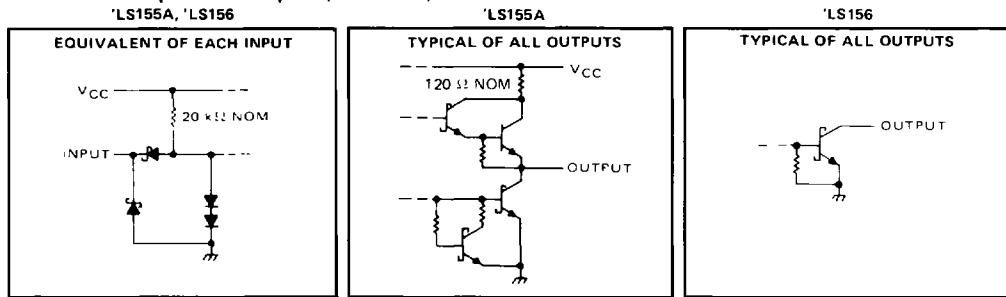

logic diagram (positive logic)

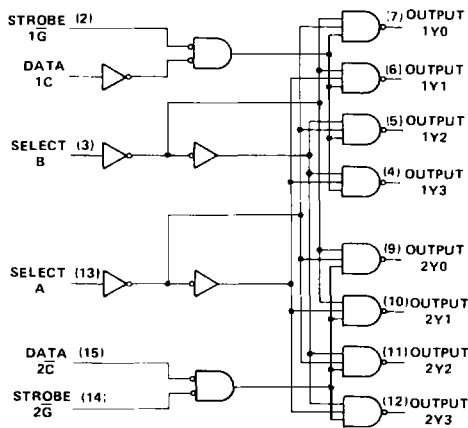

FUNCTION TABLES
2-LINE-TO-4-LINE DECODER
OR 1-LINE-TO-4-LINE DEMULTIPLEXER

SELECT		INPUTS		OUTPUTS			
B	A	STROBE 1G	DATA 1C	1Y0	1Y1	1Y2	1Y3
X	X	H	X	H	H	H	H
L	L	L	H	L	H	H	H
L	H	L	H	H	L	H	H
H	L	L	H	H	H	L	H
H	H	L	H	H	H	H	L
X	X	X	L	H	H	H	H

SELECT		INPUTS		OUTPUTS			
B	A	STROBE 2G	DATA 2C	2Y0	2Y1	2Y2	2Y3
X	X	H	X	H	H	H	H
L	L	L	L	L	H	H	H
L	H	L	L	H	L	H	H
H	L	L	L	L	H	L	H
H	H	L	L	H	H	H	L
X	X	X	H	H	H	H	H

FUNCTION TABLE
3-LINE-TO-8-LINE DECODER
OR 1-LINE-TO-8-LINE DEMULTIPLEXER

INPUTS				OUTPUTS							
SELECT			STROBE OR DATA	(0)	(1)	(2)	(3)	(4)	(5)	(6)	(7)
C†	B	A	G‡	2Y0	2Y1	2Y2	2Y3	1Y0	1Y1	1Y2	1Y3
X	X	X	H	H	H	H	H	H	H	H	H
L	L	L	L	L	H	H	H	H	H	H	H
L	L	H	L	H	L	H	H	H	H	H	H
L	H	L	L	H	H	L	H	H	H	H	H
L	H	H	L	H	H	H	L	H	H	H	H
H	L	L	L	H	H	H	H	L	H	H	H
H	L	H	L	H	H	H	H	H	L	H	H
H	H	L	L	H	H	H	H	H	H	L	H
H	H	H	L	H	H	H	H	H	H	H	L

†C = inputs 1C and 2C connected together
‡G = inputs 1G and 2G connected together
H = high level, L = low level, X = irrelevant

**SN54155, SN54156, SN54LS155A, SN54LS156,
SN74155, SN74156, SN74LS155A, SN74LS156
DUAL 2-LINE TO 4-LINE DECODERS/DEMULTIPLEXERS**

absolute maximum ratings over operating free-air temperature range (unless otherwise noted)

Supply voltage, V_{CC} (see Note 1)	7 V
Input voltage: '155, '156	5.5 V
'LS155A, 'LS156	7 V
Off-state output voltage: '156	5.5 V
'LS156	7 V
Operating free-air temperature range: SN54', SN54LS' Circuits	-55°C to 125°C
SN74', SN74LS' Circuits	0°C to 70°C
Storage temperature range	-65°C to 150°C

NOTE 1: Voltage values are with respect to network ground terminal

recommended operating conditions

	SN54155			SN74155			UNIT
	MIN	NOM	MAX	MIN	NOM	MAX	
Supply voltage, V_{CC}	4.5	5	5.5	4.75	5	5.25	V
High-level output current, I_{OH}			-800			-800	μ A
Low-level output current, I_{OL}			16			16	mA
Operating free-air temperature, T_A	-55		125	0		70	°C

electrical characteristics over recommended operating free-air temperature range (unless otherwise noted)

PARAMETER	TEST CONDITIONS†	SN54155 SN74155			UNIT
		MIN	TYP‡	MAX	
V_{IH} High-level input voltage		2			V
V_{IL} Low-level input voltage		0.8			V
V_{IK} Input clamp voltage	$V_{CC} = \text{MIN}, I_I = -8 \text{ mA}$	-1.5			V
V_{OH} High-level output voltage	$V_{CC} = \text{MIN}, V_{IH} = 2 \text{ V},$ $V_{IL} = 0.8 \text{ V}, I_{OH} = -800 \mu\text{A}$	2.4	3.4		V
V_{OL} Low-level output voltage	$V_{CC} = \text{MIN}, V_{IH} = 2 \text{ V},$ $V_{IL} = 0.8 \text{ V}, I_{OL} = 16 \text{ mA}$	0.2	0.4		V
I_I Input current at maximum input voltage	$V_{CC} = \text{MAX}, V_I = 5.5 \text{ V}$				1 mA
I_{IH} High-level input current	$V_{CC} = \text{MAX}, V_I = 2.4 \text{ V}$				40 μ A
I_{IL} Low-level input current	$V_{CC} = \text{MAX}, V_I = 0.4 \text{ V}$				-1.6 mA
I_{OS} Short-circuit output current‡	$V_{CC} = \text{MAX}$	SN54155	-20	-55	mA
		SN74155	-18	-57	
I_{CC} Supply current	$V_{CC} = \text{MAX},$ See Note 2	SN54155	25	35	mA
		SN74155	25	40	

† For conditions shown as MIN or MAX, use the appropriate value specified under recommended operating conditions

‡ All typical values are at $V_{CC} = 5 \text{ V}, T_A = 25^\circ \text{C}$.

§ Not more than one output should be shorted at a time.

NOTE 2: I_{CC} is measured with outputs open, A, B, and 1C inputs at 4.5 V, and 2C, 1G, and 2G inputs grounded.

switching characteristics, $V_{CC} = 5 \text{ V}, T_A = 25^\circ \text{C}$

PARAMETER	FROM (INPUT)	TO (OUTPUT)	LEVELS OF LOGIC	TEST CONDITIONS	SN54155 SN74155			UNIT
					MIN	TYP	MAX	
t_{PLH}	A, B, 2C, 1G, or 2G	Y	2	$C_L = 15 \text{ pF},$ $R_L = 400 \Omega,$ See Note 3	13	20	ns	
t_{PHL}	A, B, 2C, 1G, or 2G	Y	2		18	27	ns	
t_{PLH}	A or B	Y	3		21	32	ns	
t_{PHL}	A or B	Y	3		21	32	ns	
t_{PLH}	1C	Y	3		16	24	ns	
t_{PHL}	1C	Y	3		20	30	ns	

NOTE 3: Load circuits and voltage waveforms are shown in Section 1

2

TTL Devices

SN54156, SN74156 DUAL 2-LINE TO 4-LINE DECODERS/DEMULTIPLEXERS

recommended operating conditions

	SN54156			SN74156			UNIT	
	MIN	NOM	MAX	MIN	NOM	MAX		
Supply voltage, V_{CC}	4.5	5	5.5	4.75	5	5.25	V	
High-level output voltage, V_{OH}	5.5			5.5			V	
Low-level output current, I_{OL}	16			16			mA	
Operating free-air temperature, T_A	-55			0			70	C

electrical characteristics over recommended operating free-air temperature range (unless otherwise noted)

PARAMETER	TEST CONDITIONS†	SN54156 SN74156			UNIT
		MIN	TYP‡	MAX	
V_{IH} High-level input voltage		2			V
V_{IL} Low-level input voltage		0.8			V
V_{IK} Input clamp voltage	$V_{CC} = \text{MIN}, I_I = -8 \text{ mA}$	-1.5			V
I_{OH} High-level output current	$V_{CC} = \text{MIN}, V_{IH} = 2 \text{ V},$ $V_{IL} = 0.8 \text{ V}, V_{OH} = 5.5 \text{ V}$	250			μA
V_{OL} Low-level output voltage	$V_{CC} = \text{MIN}, V_{IH} = 2 \text{ V},$ $V_{IL} = 0.8 \text{ V}, I_{OL} = 16 \text{ mA}$	0.2	0.4		V
I_I Input current at maximum input voltage	$V_{CC} = \text{MAX}, V_I = 5.5 \text{ V}$	1			mA
I_{IH} High-level input current	$V_{CC} = \text{MAX}, V_I = 2.4 \text{ V}$	40			μA
I_{IL} Low-level input current	$V_{CC} = \text{MAX}, V_I = 0.4 \text{ V}$	-1.6			mA
I_{CC} Supply current	$V_{CC} = \text{MAX},$ See Note 2	SN54156	25	35	mA
		SN74156	25	40	

† For conditions shown as MIN or MAX, use the appropriate value specified under recommended operating conditions

‡ All typical values are at $V_{CC} = 5 \text{ V}, T_A = 25^\circ\text{C}$

NOTE 2 I_{CC} is measured with outputs open, A, B, and 1C inputs at 4.5 V and 2C, 1G, and 2G inputs grounded

switching characteristics, $V_{CC} = 5 \text{ V}, T_A = 25^\circ\text{C}$

PARAMETER [§]	FROM (INPUT)	TO (OUTPUT)	LEVELS OF LOGIC	TEST CONDITIONS	SN54156 SN74156			UNIT
					MIN	TYP	MAX	
t_{PLH}	A, B, 2C, 1G, or 2G	Y	2	$C_L = 15 \text{ pF},$ $R_L = 400 \Omega,$ See Note 3	15	23	ns	
t_{PHL}	A, B, 2C, 1G, or 2G	Y	2		20	30	ns	
t_{PLH}	A or B	Y	3		23	34	ns	
t_{PHL}	A or B	Y	3		23	34	ns	
t_{PLH}	1C	Y	3		18	27	ns	
t_{PHL}	1C	Y	3		22	33	ns	

[§] t_{PLH} = propagation delay time, low-to-high-level output

t_{PHL} = propagation delay time, high-to-low-level output

NOTE 3: Load circuits and voltage waveforms are shown in Section 1

2

TTL Devices

SN54LS155A, SN74LS155A DUAL 2-LINE TO 4-LINE DECODERS/DEMULTIPLEXERS

recommended operating conditions

	SN54LS155A			SN74LS155A			UNIT
	MIN	NOM	MAX	MIN	NOM	MAX	
Supply voltage, V_{CC}	4.5	5	5.5	4.75	5	5.25	V
High-level output current, I_{OH}			-400			-400	μ A
Low-level output current, I_{OL}			4			8	mA
Operating free-air temperature, T_A	-55		125	0		70	C

electrical characteristics over recommended operating free-air temperature range (unless otherwise noted)

PARAMETER	TEST CONDITIONS ¹	SN54LS155A			SN74LS155A			UNIT
		MIN	TYP ²	MAX	MIN	TYP ¹	MAX	
V_{IH} High-level input voltage		2			2			V
V_{IL} Low-level input voltage				0.7			0.8	V
V_{IK} Input clamp voltage	$V_{CC} = \text{MIN.}$, $I_I = -18 \text{ mA}$			-1.5			-1.5	V
V_{OH} High-level output voltage	$V_{CC} = \text{MIN.}$, $V_{IH} = 2 \text{ V}$, $V_{IL} = V_{IL \text{ max.}}$, $I_{OH} = -400 \mu\text{A}$	2.5	3.4		2.7	3.4		V
V_{OL} Low-level output voltage	$V_{CC} = \text{MIN.}$, $V_{IH} = 2 \text{ V}$, $V_{IL} = V_{IL \text{ max.}}$			0.25	0.4	0.25	0.4	V
I_I Input current at maximum input voltage	$V_{CC} = \text{MAX.}$, $V_I = 7 \text{ V}$			0.1			0.1	mA
I_{IH} High-level input current	$V_{CC} = \text{MAX.}$, $V_I = 2.7 \text{ V}$			20			20	μ A
I_{IL} Low-level input current	$V_{CC} = \text{MAX.}$, $V_I = 0.4 \text{ V}$			-0.4			-0.4	mA
I_{OS} Short-circuit output current ³	$V_{CC} = \text{MAX.}$	-20		-100	-20		-100	mA
I_{CC} Supply current	$V_{CC} = \text{MAX.}$, See Note 2		6.1	10		6.1	10	mA

¹ For conditions shown as MIN or MAX, use the appropriate value specified under recommended operating conditions

² All typical values are at $V_{CC} = 5 \text{ V}$, $T_A = 25^\circ \text{C}$

³ Not more than one output should be shorted at a time

NOTE 2 I_{CC} is measured with outputs open. A, B, and 1C inputs at 4.5 V and 2C, 1G, and 2G inputs grounded

switching characteristics, $V_{CC} = 5 \text{ V}$, $T_A = 25^\circ \text{C}$

PARAMETER ¹	FROM (INPUT)	TO (OUTPUT)	LEVELS OF LOGIC	TEST CONDITIONS	SN54LS155A SN74LS155A			UNIT
					MIN	TYP	MAX	
t_{PLH}	A, B, 2 \bar{C} , 1 \bar{G} , or 2 \bar{G}	Y	2	$C_L = 15 \text{ pF}$, $R_L = 2 \text{ k}\Omega$, See Note 3	10	15	ns	
t_{PHL}	A, B, 2 \bar{C} , 1 \bar{G} , or 2 \bar{G}	Y	2		19	30	ns	
t_{PLH}	A or B	Y	3		17	26	ns	
t_{PHL}	A or B	Y	3		19	30	ns	
t_{PLH}	1C	Y	3		18	27	ns	
t_{PHL}	1C	Y	3		18	27	ns	

¹ t_{PLH} = propagation delay time, low-to-high-level output

t_{PHL} = propagation delay time, high-to-low-level output

NOTE 3 Load circuits and voltage waveforms are shown in Section 1

2

TTL Devices

SN54LS156, SN74LS156

DUAL 2-LINE TO 4-LINE DECODERS/DEMULTIPLEXERS

recommended operating conditions

	SN54LS156			SN74LS156			UNIT
	MIN	NOM	MAX	MIN	NOM	MAX	
Supply voltage, V_{CC}	4.5	5	5.5	4.75	5	5.25	V
High-level output voltage, V_{OH}				5.5			V
Low-level output current, I_{OL}				4			8 mA
Operating free-air temperature, T_A	-55			125			0 70 °C

electrical characteristics over recommended operating free-air temperature range (unless otherwise noted)

PARAMETER	TEST CONDITIONS†	SN54LS156			SN74LS156			UNIT
		MIN	TYP‡	MAX	MIN	TYP‡	MAX	
V_{IH} High-level input voltage		2			2			V
V_{IL} Low-level input voltage		0.7			0.8			V
V_{IK} Input clamp voltage	$V_{CC} = \text{MIN}, I_I = -18 \text{ mA}$	-1.5			-1.5			V
I_{OH} High-level output current	$V_{CC} = \text{MIN}, V_{IH} = 2 \text{ V}, V_{IL} = V_{IL \text{ max}}, V_{OH} = 5.5 \text{ V}$	100			100			μA
V_{OL} Low-level output voltage	$V_{CC} = \text{MIN}, V_{IH} = 2 \text{ V}, V_{IL} = V_{IL \text{ max}}$	$I_{OL} = 4 \text{ mA}$	0.25	0.4	0.25	0.4	V	
		$I_{OL} = 8 \text{ mA}$			0.35	0.5		
I_I Input current at maximum input voltage	$V_{CC} = \text{MAX}, V_I = 7 \text{ V}$	0.1			0.1			mA
I_{IH} High-level input current	$V_{CC} = \text{MAX}, V_I = 2.7 \text{ V}$	20			20			μA
I_{IL} Low-level input current	$V_{CC} = \text{MAX}, V_I = 0.4 \text{ V}$	-0.4			-0.4			mA
I_{CC} Supply current	$V_{CC} = \text{MAX},$ See Note 2	6.1 10			6.1 10			mA

† For conditions shown as MIN or MAX, use the appropriate value specified under recommended operating conditions.

‡ All typical values are at $V_{CC} = 5 \text{ V}, T_A = 25^\circ\text{C}$.

NOTE 2: I_{CC} is measured with outputs open, A, B, and 1C inputs at 4.5 V, and 2C, 1G, and 2G inputs grounded.

switching characteristics, $V_{CC} = 5 \text{ V}, T_A = 25^\circ\text{C}$

PARAMETER§	FROM (INPUT)	TO (OUTPUT)	LEVELS OF LOGIC	TEST CONDITIONS	SN54LS156			UNIT
					SN74LS156			
					MIN	TYP	MAX	
t_{PLH}	A, B, 2C, 1G, or 2G	Y	2	$C_L = 15 \text{ pF},$ $R_L = 2 \text{ k}\Omega,$ See Note 3	25	40		ns
t_{PHL}	A, B, 2C, 1G, or 2G	Y	2		34	51		ns
t_{PLH}	A or B	Y	3		31	46		ns
t_{PHL}	A or B	Y	3		34	51		ns
t_{PLH}	1C	Y	3		32	48		ns
t_{PHL}	1C	Y	3		32	48		ns

§ t_{PLH} = propagation delay time, low-to-high-level output

t_{PHL} = propagation delay time, high-to-low-level output

NOTE 3: Load circuits and voltage waveforms are shown in Section 1.

2

TTL Devices