

General Description

The MIC38C4x and MIC38HC4x are fixed frequency, high performance, current-mode PWM controllers. Micrel's BiCMOS devices are pin compatible with 384x bipolar devices but feature several improvements. 'HC' versions support even faster rise and fall times than 'C' versions.

Undervoltage lockout circuitry allows the '42 and '44 versions to start up at 14.5V and operate down to 9V, and the '43 and '45 versions start at 8.4V with operation down to 7.6V. All versions operate up to 20V.

When compared to bipolar 384x devices operating from a 15V supply, start-up current has been reduced to 50µA typical and operating current has been reduced to 4.0 mA typical. Decreased output rise and fall times drive larger MOSFETs, and rail-to-rail output capability increases efficiency, especially at lower supply voltages. The MIC38C4x and MIC38HC4x also feature a trimmed oscillator discharge current and bandgap reference.

MIC38x4x denotes 8-pin plastic DIP and SOIC packages. MIC38HC4x-1 denotes 14-pin plastic DIP and SOIC packages. Devices identified as MIC18x4x are military temperature range 8-pin ceramic DIPs. 8-pin devices feature small size, while 14-pin devices separate the analog and power connections for improved performance and power dissipation.

Features

- Fast output rise/fall times:
 - 40ns rise/30ns fall for the MIC38C42
 - 20ns rise/15ns fall for the MIC38HC42
- -40°C to +85°C temperature range meets UC284x specifications
- High-performance, low-power BiCMOS Process
- Ultra-low start-up current (50µA typical)
- Low operating current (4mA typical)
- High output drive (1A peak current, HC version)
- CMOS outputs with rail-to-rail swing
- Current-mode operation $\geq 500\text{kHz}$
- Trimmed 5V bandgap reference
- Pin-for-pin compatible with UC3842/3843/3844/3845(A)
- Trimmed oscillator discharge current
- UVLO with hysteresis
- Low cross-conduction currents

Applications

- Current-mode, off-line, switched-mode power supplies
- Current-mode, dc-to-dc converters.
- Step-down "buck" regulators
- Step-up "boost" regulators
- Flyback, isolated regulators
- Forward converters
- Synchronous FET converters

Functional Diagram

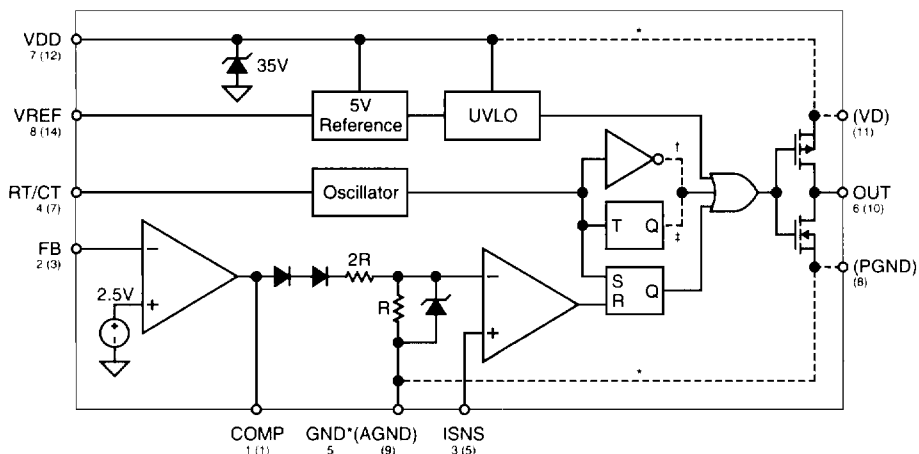

() pins are on MIC38C/HC4x-1 (14-lead) versions only
 * MICx8C/HC4x (8-lead) versions only
 † MICx8C/HC42, MICx8C/HC43 (96% max. duty cycle) versions only
 ‡ MICx8C/HC44, MICx8C/HC45 (50% max. duty cycle) versions only

Ordering Information

| Part Number | Temperature Range | Package |
|--------------------------|-------------------|--------------------|
| MIC18C42AJB [*] | -55°C to +125°C | 8-pin CerDIP |
| MIC18C43AJB [*] | -55°C to +125°C | 8-pin CerDIP |
| MIC18C44AJB [*] | -55°C to +125°C | 8-pin CerDIP |
| MIC18C45AJB [*] | -55°C to +125°C | 8-pin CerDIP |
| MIC38C42BN | -40°C to +85°C | 8-pin Plastic DIP |
| MIC38C43BN | -40°C to +85°C | 8-pin Plastic DIP |
| MIC38C44BN | -40°C to +85°C | 8-pin Plastic DIP |
| MIC38C45BN | -40°C to +85°C | 8-pin Plastic DIP |
| MIC38C42-1BN | -40°C to +85°C | 14-pin Plastic DIP |
| MIC38C43-1BN | -40°C to +85°C | 14-pin Plastic DIP |
| MIC38C44-1BN | -40°C to +85°C | 14-pin Plastic DIP |
| MIC38C45-1BN | -40°C to +85°C | 14-pin Plastic DIP |
| MIC38C42BM | -40°C to +85°C | 8-pin SOIC |
| MIC38C43BM | -40°C to +85°C | 8-pin SOIC |
| MIC38C44BM | -40°C to +85°C | 8-pin SOIC |
| MIC38C45BM | -40°C to +85°C | 8-pin SOIC |
| MIC38C42-1BM | -40°C to +85°C | 14-pin SOIC |
| MIC38C43-1BM | -40°C to +85°C | 14-pin SOIC |
| MIC38C44-1BM | -40°C to +85°C | 14-pin SOIC |
| MIC38C45-1BM | -40°C to +85°C | 14-pin SOIC |

| Part Number | Temperature Range | Package |
|---------------|-------------------|--------------------|
| MIC38HC42BN | -40°C to +85°C | 8-pin Plastic DIP |
| MIC38HC43BN | -40°C to +85°C | 8-pin Plastic DIP |
| MIC38HC44BN | -40°C to +85°C | 8-pin Plastic DIP |
| MIC38HC45BN | -40°C to +85°C | 8-pin Plastic DIP |
| MIC38HC42-1BN | -40°C to +85°C | 14-pin Plastic DIP |
| MIC38HC43-1BN | -40°C to +85°C | 14-pin Plastic DIP |
| MIC38HC44-1BN | -40°C to +85°C | 14-pin Plastic DIP |
| MIC38HC45-1BN | -40°C to +85°C | 14-pin Plastic DIP |
| MIC38HC42BM | -40°C to +85°C | 8-pin SOIC |
| MIC38HC43BM | -40°C to +85°C | 8-pin SOIC |
| MIC38HC44BM | -40°C to +85°C | 8-pin SOIC |
| MIC38HC45BM | -40°C to +85°C | 8-pin SOIC |
| MIC38HC42-1BM | -40°C to +85°C | 14-pin SOIC |
| MIC38HC43-1BM | -40°C to +85°C | 14-pin SOIC |
| MIC38HC44-1BM | -40°C to +85°C | 14-pin SOIC |
| MIC38HC45-1BM | -40°C to +85°C | 14-pin SOIC |

Refer to the Part Number Cross Reference for a listings of Micrel devices equivalent to UC284x and UC384x devices.
^{*}AJB indicates units screened to MIL-STD-883, class B, and burned in for 168 hours minimum.

Selection Guide

| Duty Cycle | UVLO Thresholds | |
|------------|--|---------------------------------------|
| | Startup 8.4V Minimum Operating 7.6V | Startup 14.5V Minimum Operating 9V |
| 0% to 96% | MIC18C43 MIC38C43/HC43 | MIC18C42 MIC38C42/HC42 |
| 0% to 50% | MIC18C45 MIC38C45/HC45 | MIC18C44 MIC38C44/HC44 |

Pin Configuration

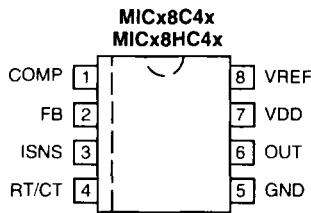

8-Pin DIP (N, J)
8-Lead SOIC (M)

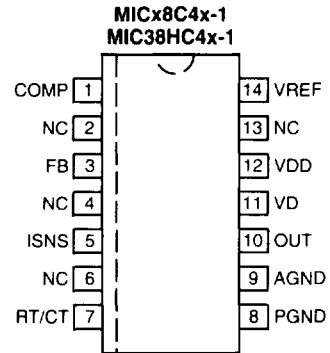

14-Pin DIP (-1xN)
14-Lead SOIC (-1xM)

Pin Description

| Pin Number N, J, M | Pin Number -1xN, -1xM | Pin Name | Pin Function |
|-----------------------|--------------------------|----------|--|
| 1 | 1 | COMP | Compensation: Connect external compensation network to modify the error amplifier output. |
| | 2 | NC | Not internally connected. |
| 2 | 3 | FB | Feedback (Input): Error amplifier input. Feedback is 2.5V at desired output voltage. |
| | 4 | NC | Not internally connected. |
| 3 | 5 | ISNS | Current Sense (Input): Current sense comparator input. Connect to current sensing resistor or current transformer. |
| | 6 | NC | Not internally connected. |
| 4 | 7 | RT/CT | Timing Resistor/Timing Capacitor: Connect external RC network to select switching frequency. |
| 5 | | GND | Ground: Combined analog and power ground. |
| | 8 | PGND | Power Ground: N-channel driver transistor ground. |
| | 9 | AGND | Analog Ground: Controller circuitry ground. |
| 6 | 10 | OUT | Power Output: Totem-pole output. |
| | 11 | VD | Power Supply (Input): P-channel driver transistor supply input. Return to power ground (PGND). |
| 7 | 12 | VDD | Analog Supply (Input): Controller circuitry supply input. Return to analog ground (AGND). |
| | 13 | NC | Not internally connected. |
| 8 | 14 | VREF | 5V Reference (Output): Connect external RC network. |

Absolute Maximum Ratings

Zener Current 30mA

Operation at $\geq 18V$ may require**special precautions (see Applications Information).**

VDD 20V

VD (x8C4x-1, 38HC4x-1) 20V

ISNS -0.3V to 5.5V

FB -0.3V to 5.5V

Output Current (x8C42/43/44/45) 0.5A

Output Current (x8HC42/43/44/45) 1A

Operating Junction Temperature 150°C

Package Thermal Resistance

 θ_{JA} 8-Pin Plastic DIP 100°C/W θ_{JA} 8-Pin Ceramic DIP 125°C/W θ_{JA} 8-Pin SOIC 170°C/W θ_{JA} 14-Pin Plastic DIP 90°C/W θ_{JA} 14-Pin Ceramic DIP 110°C/W θ_{JA} 14-Pin SOIC 145°C/W

Storage Temperature -65°C to 150°C

Electrical Characteristics $V_{DD} = 15V$ (Note 4), $R_T = 10k\Omega$, $C_T = 3.3nF$ -55 $\leq T_A \leq 125^\circ C$ for MIC18C42/43/44/45; -40 $\leq T_A \leq 85^\circ C$ for MIC38C42/43/44/45, 38HC42/43/44/45

| Parameter | Test Conditions | MIC18C42/43/44/45 MIC18HC42/43/44/45 | | | MIC38C42/43/44/45 MIC38HC42/43/44/45 | | | Units |
|---------------------------|--|---|------|------|---|------|------|------------------|
| | | Min | Typ | Max | Min | Typ | Max | |
| Reference Section | | | | | | | | |
| Output Voltage | $T_A = 25^\circ C$, $I_O = 1mA$ | 4.95 | 5.00 | 5.05 | 4.90 | 5.00 | 5.10 | V |
| Line Regulation | $12V \leq V_{DD} \leq 18V$, $I_O = 5 \mu A$ (Note 6) | | 2 | 20 | | 2 | 20 | mV |
| Load Regulation | $1 \leq I_O \leq 20 mA$ | | 1 | 25 | | 1 | 25 | mV |
| Temp. Stability | (Note 1) | | 0.2 | | | 0.2 | | mV/ $^\circ C$ |
| Total Output Variation | Line, Load, Temp. (Note 1) | 4.9 | | 5.1 | 4.82 | | 5.18 | V |
| Output Noise Voltage | $10Hz \leq f \leq 10kHz$, $T_A = 25^\circ C$ (Note 1) | | 50 | | | 50 | | μV |
| Long Term Stability | $T_A = 125^\circ C$, 1000 Hrs. (Note 1) | | 5 | 25 | | 5 | 25 | mV |
| Output Short Circuit | | -30 | -80 | -180 | -30 | -80 | -180 | mA |
| Oscillator Section | | | | | | | | |
| Initial Accuracy | $T_A = 25^\circ C$ (Note 5) | 49 | 52 | 55 | 49 | 52 | 55 | kHz |
| Voltage Stability | $12 \leq V_{DD} \leq 18V$ (Note 6) | | 0.2 | 1.0 | | 0.2 | 1.0 | % |
| Temp. Stability | $T_{MIN} \leq T_A \leq T_{MAX}$ (Note 1) | | 0.04 | | | 0.04 | | %/ $^\circ C$ |
| Clock Ramp | $T_A = 25^\circ C$, $V_{RT/CT} = 2V$ | 7.7 | 8.4 | 9.0 | 7.7 | 8.4 | 9.0 | mA |
| Reset Current | $T_A = T_{MIN}$ to T_{MAX} | 7.2 | 8.4 | 9.5 | 7.2 | 8.4 | 9.5 | mA |
| Amplitude | $V_{RT/CT}$ peak to peak | | 1.9 | | | 1.9 | | V _{p-p} |
| Error Amp Section | | | | | | | | |
| Input Voltage | $V_{COMP} = 2.5V$ | 2.45 | 2.50 | 2.55 | 2.42 | 2.50 | 2.58 | V |
| Input Bias Current | $V_{FEEDBACK} = 5.0V$ | | -0.1 | -1 | | -0.1 | -2 | μA |
| A_{VOL} | $2 \leq V_O \leq 4V$ | 65 | 90 | | 65 | 90 | | dB |
| Unity Gain Bandwidth | (Note 1) | 0.7 | 1.0 | | 0.7 | 1.0 | | MHz |
| PSRR | $12 \leq V_{DD} \leq 18V$ | 60 | | | 60 | | | dB |
| Output Sink Current | $V_{FEEDBACK} = 2.7V$, $V_{COMP} = 1.1V$ | 2 | 14 | | 2 | 14 | | mA |
| Output Source Current | $V_{FEEDBACK} = 2.3V$, $V_{COMP} = 5V$ | -0.5 | -1 | | -0.5 | -1 | | mA |
| V_{OUT} High | $V_{FEEDBACK} = 2.3V$, $R_L = 15k$ to ground | 5 | 6.8 | | 5 | 6.8 | | V |
| V_{OUT} Low | $V_{FEEDBACK} = 2.7V$, $R_L = 15k$ to V_{REF} | | 0.1 | 1.1 | | 0.1 | 1.1 | V |

| Parameter | Test Conditions | MIC18C42/43/44/45 MIC18HC42/43/44/45 | | | MIC38C42/43/44/45 MIC38HC42/43/44/45 | | | Units |
|------------------------------|---|---|------|------|---|------|------|----------|
| | | Min | Typ | Max | Min | Typ | Max | |
| Current Sense | | | | | | | | |
| Gain | (Notes 2 & 3) | 2.85 | 3.0 | 3.15 | 2.85 | 3.0 | 3.15 | V/V |
| Maximum Threshold | $V_{COMP} = 5V$ (Note 2) | 0.9 | 1 | 1.1 | 0.9 | 1 | 1.1 | V |
| PSRR | $12 \leq V_{DD} \leq 18V$ (Note 2) | | 70 | | | 70 | | dB |
| Input Bias Current | | | -0.1 | -1 | | -0.1 | -2 | μA |
| Delay to Output | | | 120 | 250 | | 120 | 250 | ns |
| Output | | | | | | | | |
| $R_{DS(ON)}$ 'C' High | $I_{SOURCE} = 200 mA$ | | 20 | | | 20 | | Ω |
| $R_{DS(ON)}$ 'C' Low | $I_{SINK} = 200 mA$ | | 11 | | | 11 | | Ω |
| $R_{DS(ON)}$ 'HC' High | $I_{SOURCE} = 200 mA$ | | 10 | | | 10 | | Ω |
| $R_{DS(ON)}$ 'HC' Low | $I_{SINK} = 200 mA$ | | 5.5 | | | 5.5 | | Ω |
| Rise Time: 'C' version | $T_A = 25^\circ C, C_L = 1 nF$ | | 40 | 80 | | 40 | 80 | ns |
| Fall Time: 'C' version | $T_A = 25^\circ C, C_L = 1 nF$ | | 30 | 60 | | 30 | 60 | ns |
| Rise Time: 'HC' version | $T_A = 25^\circ C, C_L = 1 nF$ | | 20 | 50 | | 20 | 50 | ns |
| Fall Time: 'HC' version | $T_A = 25^\circ C, C_L = 1 nF$ | | 15 | 40 | | 15 | 40 | ns |
| Undervoltage Lockout | | | | | | | | |
| Start Threshold | 38C42/4, 18C42/4, 38HC42/4, 18HC42/4 | 13.5 | 14.5 | 15.5 | 13.5 | 14.5 | 15.5 | V |
| | 38C43/5, 18C43/5, 38HC43/5, 18HC43/5 | 7.8 | 8.4 | 9.0 | 7.8 | 8.4 | 9.0 | V |
| Min. Operating Voltage | 38C42/4, 18C42/4, 38C42/4, 18HC42/4 | 8 | 9 | 10 | 8 | 9 | 10 | V |
| | 38C43/5, 38C43/5, 38HC43/5, 38HC43/5 | 7.0 | 7.6 | 8.2 | 7.0 | 7.6 | 8.2 | V |
| Pulse Width Modulator | | | | | | | | |
| Maximum Duty Cycle | 38C42/3, 18C42/3, 38HC42/3, 18HC42/3 | 94 | 96 | | 94 | 96 | | % |
| | 38C44/5, 18C44/5, 38HC44/5, 18HC44/5 | 46 | 50 | | 46 | 50 | | % |
| Minimum Duty Cycle | | | | 0 | | | 0 | % |
| Total Standby Current | | | | | | | | |
| Start-Up Current | $V_{DD} = 13V$ for x8C42/44, x8HC42/44 $V_{DD} = 7.5V$ for x8C43/45, x8HC43/45 | | 50 | 150 | | 50 | 200 | μA |
| Operating Supply Current | $V_{FEEDBACK} = V_{I SENSE} = 0V$ | | 4.0 | 6.0 | | 4.0 | 6.0 | mA |
| Zener Voltage (V_{DD}) | $I_{DD} = 25mA$ (Note 6) | 30 | 37 | | 30 | 37 | | V |

Note 1: These parameters, although guaranteed, are not 100% tested in production.

Note 2: Parameter measured at trip point of latch with $V_{EA} = 0$.

Note 3: Gain measured as:

$$A = \frac{\Delta V_{PINT}}{V_{TH}(I_{SENSE})} ; 0 \leq V_{TH}(I_{SENSE}) \leq 0.8V$$

Note 4: Adjust V_{DD} above the start threshold before setting at 15V.

Note 5: Output frequency equals oscillator frequency for the '8C42 and '8C43. Output frequency for the '8C44, and '8C45 equals one half the oscillator frequency.

Note 6: On 8-pin version, 20V is maximum input on pin 7, as this is also the supply pin for the output stage. On 14-pin version, 40V is maximum for pin 12 and 20V maximum for pin 11.

Typical Characteristics

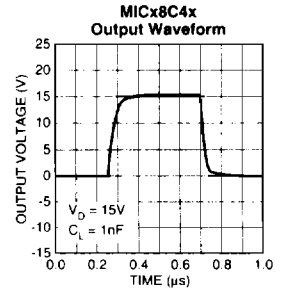
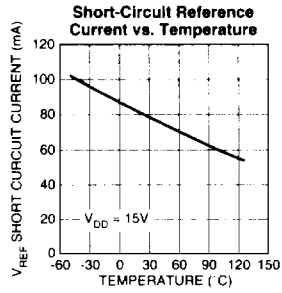
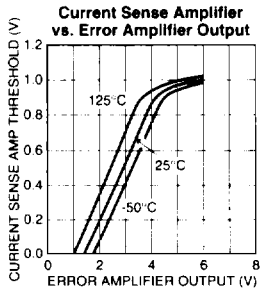
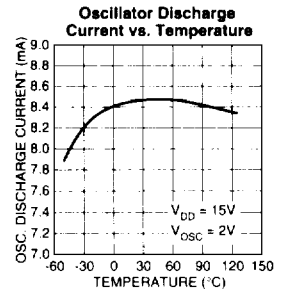
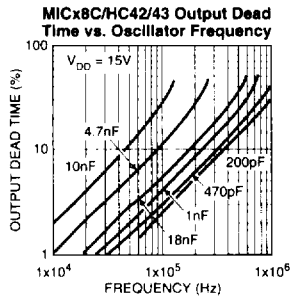
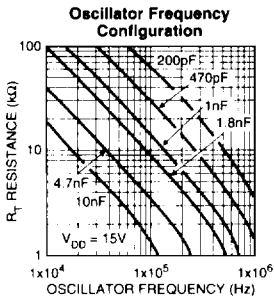

Application Information

Familiarity with 384x converter designs is assumed.

The MICx8C4x and MICx8HC4x have been designed to be compatible with 384xA series controllers. Micrel's 'C' and 'HC' controllers are intended for existing and new designs.

MIC38C4x and MIC38HC4x Advantages

Start-up Current

Start-up current has been reduced to an ultra-low 50 μ A (typical) permitting higher-valued, lower-wattage, start-up resistors (powers controller during power supply start-up). The reduced resistor wattage reduces cost and printed circuit space.

Operating Current

Operating current has been reduced to 4mA compared to 11mA for a typical bipolar controller. The controller runs cooler and the V_{DD} hold-up capacitance required during start-up may be reduced.

Output Driver

Complementary internal P- and N-channel MOSFETs produce rail-to-rail output voltages for better performance driving external power MOSFETs. The driver transistor's low on-resistance and high peak current capability can drive gate capacitances of greater than 1000pF. The value of output capacitance which can be driven is determined only by the rise/fall time requirements. Within the restrictions of output capacity and controller power dissipation, switching frequencies can approach 1MHz.

Design Precautions

When operating near 20V, circuit transients can easily exceed the 20V absolute maximum rating, permanently damag-

ing the controller's CMOS construction. To reduce transients, use a 0.1 μ F low-ESR capacitor to next to the controller's supply V_{DD} (or V_D for '-1' versions) and ground connections. Film type capacitors, such as Wima MKS2, are recommended.

When designing high-frequency converters, avoid capacitive and inductive coupling of the switching waveform into high-impedance circuitry such as the error amplifier, oscillator, and current sense amplifier. Avoid long printed-circuit traces and component leads. Locate oscillator and compensation circuitry near the IC. Use high frequency decoupling capacitors on V_{REF} , and if necessary, on V_{DD} . Return high di/dt currents directly to their source and use large area ground planes.

Buck Converter

Refer to figure 1. When at least 26V is applied to the input, C5 is charged through R2 until the voltage V_{DD} is greater than 14.5V (the undervoltage lockout value of the MIC38C42). Output switching begins when Q1 is turned on by the gate drive transformer T1, charging the output filter capacitor C3 through L1. D5 supplies a regulated +12V to V_{DD} once the circuit is running.

Current sense transformer CT1 provides current feedback to ISNS for current-mode operation and cycle-by-cycle current limiting. This is more efficient than a high-power sense resistor and provides the required ground-referenced level shift.

When Q1 turns off, current flow continues from ground through D1 and L1 until Q1 is turned on again.

The 100V Schottky diode D1 reduces the forward voltage drop in the main current path, resulting in higher efficiency than could be accomplished using an ultra-fast-recovery diode. R1 and C2 suppress parasitic oscillations from D1.

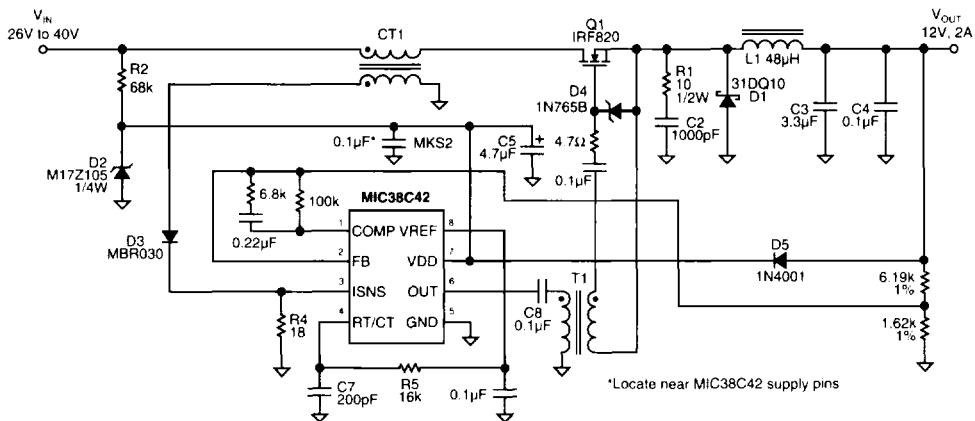

Figure 1. 500kHz, 25W, Buck Converter

Using a high-value inductance for L1 and a low-ESR capacitor for C3 permits small capacitance with minimum output ripple. This inductance value also improves circuit efficiency by reducing the flux swing in L1.

Magnetic components are carefully chosen for minimal loss at 500kHz. CT1 and T1 are wound on Magnetics, Inc. P-type material toroids. L1 is wound on a Siemens N49 EFD core.

| Test | Conditions | Results |
|-----------------|--|---------|
| Line Regulation | $V_{IN} = 26V$ to $80V$, $I_O = 2A$ | 0.5% |
| Load Regulation | $V_{IN} = 48V$, $I_O = 0.2A$ to $2A$ | 0.6% |
| Efficiency | $V_{IN} = 48V$, $I_O = 2A$ | 90% |
| Output Ripple | $V_{IN} = 48V$, $I_O = 2A$ (20MHz BW) | 100mV |

| Symbol | Custom Coil ¹ | ETS ² |
|--------|--------------------------|------------------|
| CT1 | 4923 | ETS 92420 |
| T1 | 4924 | ETS 92419 |
| L1 | 4925 | ETS 92421 |

1. Custom Coils, Alcester, SD tel: (605) 934-2460
2. Energy Transformation Systems, Inc. tel: (415) 324-4949.

Synchronous Buck Converter

Refer to figure 2. This MIC38C43 synchronous buck converter uses an MIC5022 half-bridge driver to alternately drive the PWM switch MOSFET (driven by GATEH, or high-side output) and a MOSFET which functions as a synchronous rectifier (driven by the GATEL, or low-side output).

The low-side MOSFET turns on when the high-side MOSFET is off, allowing current to return from ground. Current flows through the low-side MOSFET in the source to drain direction.

The on-state voltage drop of the low-side MOSFET is lower than the forward voltage drop of an equivalent Schottky rectifier. This lower voltage drop results in higher efficiency. A sense resistor (5mΩ) is connected to the driver's high-side current sense inputs to provide overcurrent protection. Refer to the MIC5020, MIC5021, and MIC5022 data sheets for more information.

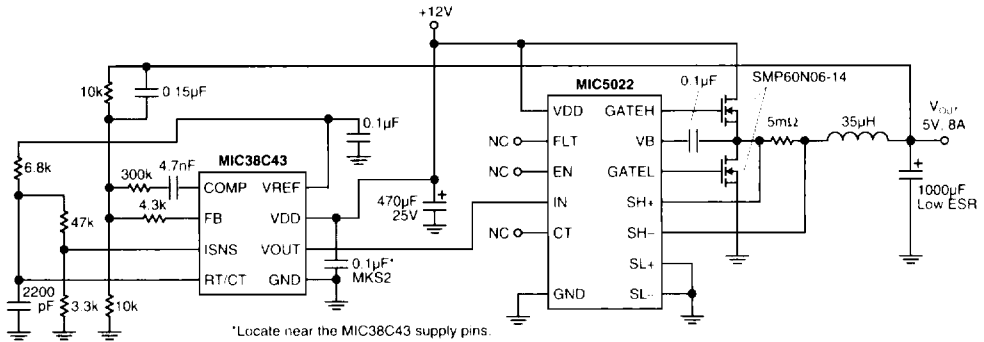

Figure 2. 100kHz, Synchronous Buck Converter