

CD4093BM/CD4093BC



T-51-21

## CD4093BM/CD4093BC Quad 2-Input NAND Schmitt Trigger

### General Description

The CD4093B consists of four Schmitt-trigger circuits. Each circuit functions as a 2-input NAND gate with Schmitt-trigger action on both inputs. The gate switches at different points for positive and negative-going signals. The difference between the positive ( $V_{T+}$ ) and the negative voltage ( $V_{T-}$ ) is defined as hysteresis voltage ( $V_H$ ).

All outputs have equal source and sink currents and conform to standard B-series output drive (see Static Electrical Characteristics).

### Features

- Wide supply voltage range 3.0V to 15V
- Schmitt-trigger on each input with no external components
- Noise immunity greater than 50%

- Equal source and sink currents
- No limit on input rise and fall time
- Standard B-series output drive
- Hysteresis voltage (any input)  $T_A = 25^\circ\text{C}$

Typical	$V_{DD} = 5.0\text{V}$	$V_H = 1.5\text{V}$
	$V_{DD} = 10\text{V}$	$V_H = 2.2\text{V}$
	$V_{DD} = 15\text{V}$	$V_H = 2.7\text{V}$
Guaranteed		$V_H = 0.1 V_{DD}$

### Applications

- Wave and pulse shapers
- High-noise-environment systems
- Monostable multivibrators
- Astable multivibrators
- NAND logic

### Connection Diagram

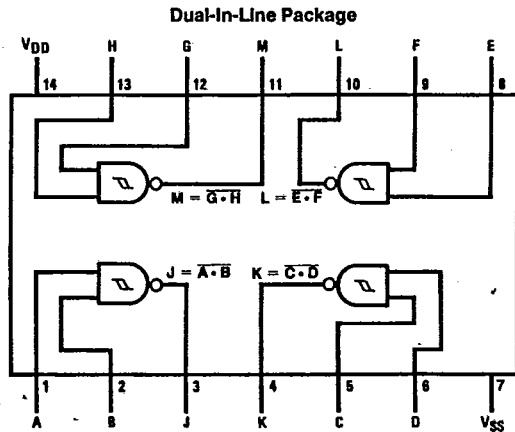

TL/F/5982-1

Top View

Order Number CD4093B\*

\*Please look into Section 8, Appendix D for availability of various package types.

T-51-21

**Absolute Maximum Ratings** (Notes 1 & 2)

If Military/Aerospace specified devices are required, contact the National Semiconductor Sales Office/Distributors for availability and specifications.

DC Supply Voltage (V <sub>DD</sub> )	-0.5 to +18 V <sub>DC</sub>
Input Voltage (V <sub>IN</sub> )	-0.5 to V <sub>DD</sub> + 0.5 V <sub>DC</sub>
Storage Temperature Range (T <sub>S</sub> )	-65°C to +150°C
Power Dissipation (P <sub>D</sub> )	
Dual-In-Line	700 mW
Small Outline	500 mW
Lead Temperature (T <sub>L</sub> )	
(Soldering, 10 seconds)	260°C

**Recommended Operating Conditions** (Note 2)

DC Supply Voltage (V <sub>DD</sub> )	3 to 15 V <sub>DC</sub>
Input Voltage (V <sub>IN</sub> )	0 to V <sub>DD</sub> V <sub>DC</sub>
Operating Temperature Range (T <sub>A</sub> )	
CD4093BM	-55°C to +125°C
CD4093BC	-40°C to +85°C

CD4093BM/CD4093BC

**DC Electrical Characteristics** CD4093BM (Note 2)

Symbol	Parameter	Conditions	-55°C		+25°C			+125°C		Units
			Min	Max	Min	Typ	Max	Min	Max	
I <sub>DD</sub>	Quiescent Device Current	V <sub>DD</sub> = 5V		0.25				0.25	7.5	μA
		V <sub>DD</sub> = 10V		0.5				0.5	15.0	μA
		V <sub>DD</sub> = 15V		1.0				1.0	30.0	μA
V <sub>OL</sub>	Low Level Output Voltage	V <sub>IN</sub> = V <sub>DD</sub> ,  I <sub>O</sub>   < 1 μA								
		V <sub>DD</sub> = 5V		0.05		0	0.05		0.05	V
		V <sub>DD</sub> = 10V		0.05		0	0.05		0.05	V
V <sub>OH</sub>	High Level Output Voltage	V <sub>IN</sub> = V <sub>SS</sub> ,  I <sub>O</sub>   < 1 μA								
		V <sub>DD</sub> = 5V	4.95		4.95	5		4.95		V
		V <sub>DD</sub> = 10V	9.95		9.95	10		9.95		V
V <sub>T</sub> <sup>-</sup>	Negative-Going Threshold Voltage (Any Input)	V <sub>DD</sub> = 5V, V <sub>O</sub> = 4.5V	1.3	2.25	1.5	1.8	2.25	1.5	2.3	V
		V <sub>DD</sub> = 10V, V <sub>O</sub> = 9V	2.85	4.5	3.0	4.1	4.5	3.0	4.65	V
		V <sub>DD</sub> = 15V, V <sub>O</sub> = 13.5V	4.35	6.75	4.5	6.3	6.75	4.5	6.9	V
V <sub>T</sub> <sup>+</sup>	Positive-Going Threshold Voltage (Any Input)	V <sub>DD</sub> = 5V, V <sub>O</sub> = 0.5V	2.75	3.65	2.75	3.3	3.5	2.65	3.5	V
		V <sub>DD</sub> = 10V, V <sub>O</sub> = 1V	5.5	7.15	5.5	6.2	7.0	5.35	7.0	V
		V <sub>DD</sub> = 15V, V <sub>O</sub> = 1.5V	8.25	10.65	8.25	9.0	10.5	8.1	10.5	V
V <sub>H</sub>	Hysteresis (V <sub>T</sub> <sup>+</sup> - V <sub>T</sub> <sup>-</sup> ) (Any Input)	V <sub>DD</sub> = 5V	0.5	2.35	0.5	1.5	2.0	0.35	2.0	V
		V <sub>DD</sub> = 10V	1.0	4.30	1.0	2.2	4.0	0.70	4.0	V
		V <sub>DD</sub> = 15V	1.5	6.30	1.5	2.7	6.0	1.20	6.0	V
I <sub>OL</sub>	Low Level Output Current (Note 3)	V <sub>IN</sub> = V <sub>DD</sub>								
		V <sub>DD</sub> = 5V, V <sub>O</sub> = 0.4V	0.64		0.51	0.88		0.36		mA
		V <sub>DD</sub> = 10V, V <sub>O</sub> = 0.5V	1.6		1.3	2.25		0.9		mA
I <sub>OH</sub>	High Level Output Current (Note 3)	V <sub>IN</sub> = V <sub>SS</sub>								
		V <sub>DD</sub> = 5V, V <sub>O</sub> = 4.6V	-0.64		0.51	-0.88		-0.36		mA
		V <sub>DD</sub> = 10V, V <sub>O</sub> = 9.5V	-1.6		-1.3	-2.25		-0.9		mA
I <sub>IN</sub>	Input Current	V <sub>DD</sub> = 15V, V <sub>IN</sub> = 0V		-0.1		-10 <sup>-5</sup>	-0.1		-1.0	μA
		V <sub>DD</sub> = 15V, V <sub>IN</sub> = 15V		0.1		10 <sup>-5</sup>	0.1		1.0	μA

Note 1: "Absolute Maximum Ratings" are those values beyond which the safety of the device cannot be guaranteed; they are not meant to imply that the devices should be operated at these limits. The table of "Recommended Operating Conditions" and "Electrical Characteristics" provides conditions for actual device operation.

Note 2: V<sub>SS</sub> = 0V unless otherwise specified.

Note 3: I<sub>OH</sub> and I<sub>OL</sub> are tested one output at a time.

5

CD4093BM/CD4093BC

**DC Electrical Characteristics** CD4093BC (Note 2)

T-51-21

Symbol	Parameter	Conditions	-40°C		+25°C			+85°C		Units
			Min	Max	Min	Typ	Max	Min	Max	
I <sub>DD</sub>	Quiescent Device Current	V <sub>DD</sub> = 5V		1.0			1.0		7.5	μA
		V <sub>DD</sub> = 10V		2.0			2.0		15.0	μA
		V <sub>DD</sub> = 15V		4.0			4.0		30.0	μA
V <sub>OL</sub>	Low Level Output Voltage	V <sub>IN</sub> = V <sub>DD</sub> ,  I <sub>O</sub>   < 1 μA								
		V <sub>DD</sub> = 5V		0.05		0	0.05		0.05	V
		V <sub>DD</sub> = 10V		0.05		0	0.05		0.05	V
V <sub>OH</sub>	High Level Output Voltage	V <sub>IN</sub> = V <sub>SS</sub> ,  I <sub>O</sub>   < 1 μA								
		V <sub>DD</sub> = 5V	4.95		4.95	5		4.95		V
		V <sub>DD</sub> = 10V	9.95		9.95	10		9.95		V
V <sub>T-</sub>	Negative-Going Threshold Voltage (Any Input)	I <sub>O</sub>   < 1 μA								
		V <sub>DD</sub> = 5V, V <sub>O</sub> = 4.5V	1.3	2.25	1.5	1.8	2.25	1.5	2.3	V
		V <sub>DD</sub> = 10V, V <sub>O</sub> = 9V	2.85	4.5	3.0	4.1	4.5	3.0	4.65	V
V <sub>T+</sub>	Positive-Going Threshold Voltage (Any Input)	I <sub>O</sub>   < 1 μA								
		V <sub>DD</sub> = 5V, V <sub>O</sub> = 0.5V	2.75	3.6	2.75	3.3	3.5	2.65	3.5	V
		V <sub>DD</sub> = 10V, V <sub>O</sub> = 1V	5.5	7.15	5.5	6.2	7.0	5.35	7.0	V
V <sub>H</sub>	Hysteresis (V <sub>T+</sub> - V <sub>T-</sub> ) (Any Input)	V <sub>DD</sub> = 5V	0.5	2.35	0.5	1.5	2.0	0.35	2.0	V
		V <sub>DD</sub> = 10V	1.0	4.3	1.0	2.2	4.0	0.70	4.0	V
		V <sub>DD</sub> = 15V	1.5	6.3	1.5	2.7	6.0	1.20	6.0	V
I <sub>OL</sub>	Low Level Output Current (Note 3)	V <sub>IN</sub> = V <sub>DD</sub>								
		V <sub>DD</sub> = 5V, V <sub>O</sub> = 0.4V	0.52		0.44	0.88		0.36		mA
		V <sub>DD</sub> = 10V, V <sub>O</sub> = 0.5V	1.3		1.1	2.25		0.9		mA
I <sub>OH</sub>	High Level Output Current (Note 3)	V <sub>IN</sub> = V <sub>SS</sub>								
		V <sub>DD</sub> = 5V, V <sub>O</sub> = 4.6V	-0.52		0.44	-0.88		-0.36		mA
		V <sub>DD</sub> = 10V, V <sub>O</sub> = 9.5V	-1.3		-1.1	-2.25		-0.9		mA
I <sub>IN</sub>	Input Current	V <sub>DD</sub> = 15V, V <sub>IN</sub> = 0V		-0.3		-10 <sup>-5</sup>	-0.3		-1.0	μA
		V <sub>DD</sub> = 15V, V <sub>IN</sub> = 15V		0.3		10 <sup>-5</sup>	0.3		1.0	μA

**AC Electrical Characteristics\***

T<sub>A</sub> = 25°C, C<sub>L</sub> = 50 pF, R<sub>L</sub> = 200k, Input t<sub>r</sub>, t<sub>f</sub> = 20 ns, unless otherwise specified

Symbol	Parameter	Conditions	Min	Typ	Max	Units
t <sub>PHL</sub> , t <sub>PLH</sub>	Propagation Delay Time	V <sub>DD</sub> = 5V		300	450	ns
		V <sub>DD</sub> = 10V		120	210	ns
		V <sub>DD</sub> = 15V		80	160	ns
t <sub>THL</sub> , t <sub>TLH</sub>	Transition Time	V <sub>DD</sub> = 5V		90	145	ns
		V <sub>DD</sub> = 10V		50	75	ns
		V <sub>DD</sub> = 15V		40	60	ns
C <sub>IN</sub>	Input Capacitance	(Any Input)		5.0	7.5	pF
C <sub>PD</sub>	Power Dissipation Capacitance	(Per Gate)		24		pF

\*AC Parameters are guaranteed by DC correlated testing.  
 Note 2: V<sub>SS</sub> = 0V unless otherwise specified.  
 Note 3: I<sub>OH</sub> and I<sub>OL</sub> are tested one output at a time.

# Typical Applications

T-51-21

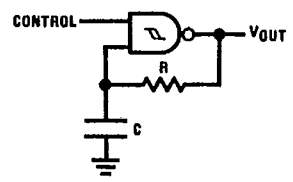

Assume  $t_1 + t_2 \gg t_{PHL} + t_{PLH}$  then:  
 $t_0 = RC \ln [V_{DD}/V_{T-}]$   
 $t_1 = RC \ln [(V_{DD} - V_{T-})/(V_{DD} + V_{T+})]$   
 $t_2 = RC \ln [V_{T+}/V_{T-}]$

$$f = \frac{1}{t_1 + t_2} = \frac{1}{RC \ln \frac{(V_{T+})(V_{DD} - V_{T-})}{(V_{T-})(V_{DD} + V_{T+})}}$$

## Gated Oscillator

TL/F/5982-2

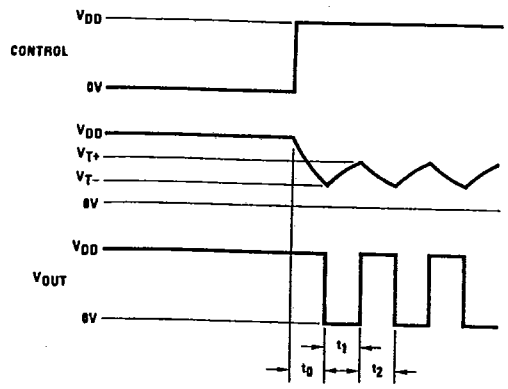

TL/F/5982-3

## Gated One-Shot

TL/F/5982-4

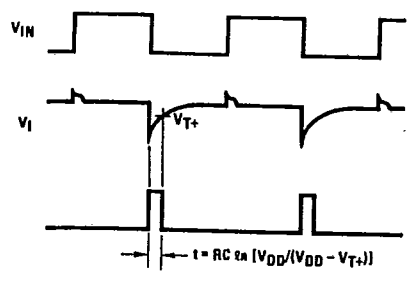
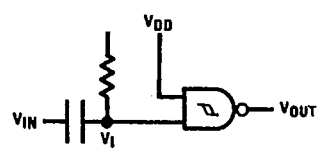

TL/F/5982-5

### (a) Negative-Edge Triggered

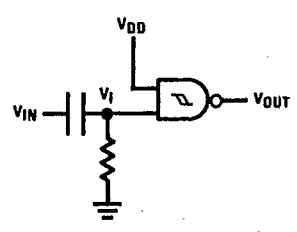

TL/F/5982-6

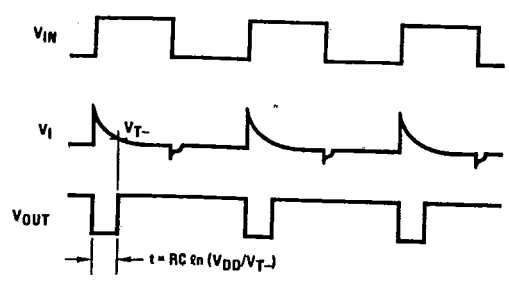

TL/F/5982-7

### (b) Positive-Edge Triggered

CD4093BM/CD4093BC

Typical Performance Characteristics

T-51-21

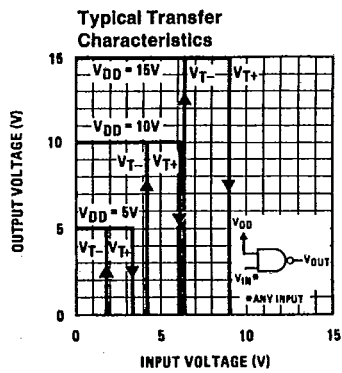

TL/F/5982-8

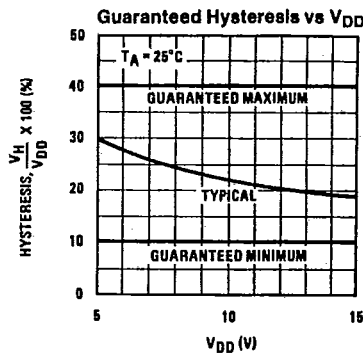

TL/F/5982-9

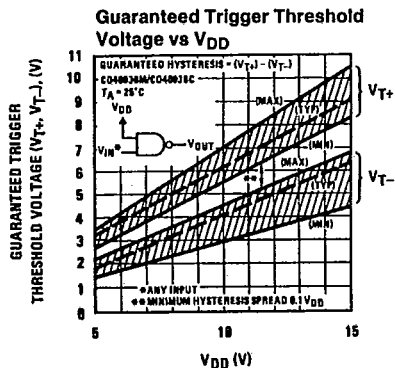

TL/F/5982-10

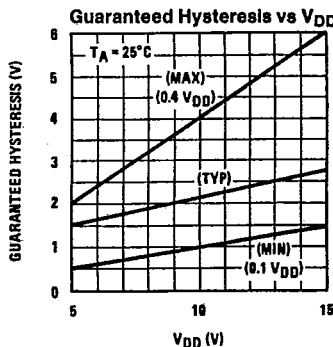

TL/F/5982-11

Input and Output Characteristics

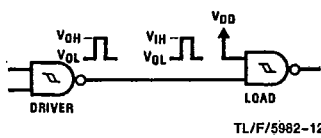

TL/F/5982-12

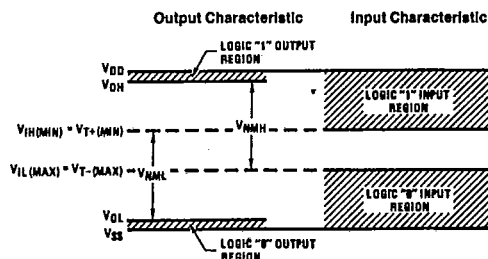

TL/F/5982-13

$$V_{NML} = V_{IH(MIN)} - V_{OL} \approx V_{IH(MIN)} - V_{T+ (MIN)}$$

$$V_{NMH} = V_{OH} - V_{IL(MAX)} \approx V_{DD} - V_{IL(MAX)} = V_{DD} - V_{T- (MAX)}$$

AC Test Circuits and Switching Time Waveforms

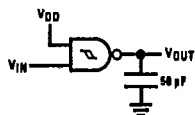

TL/F/5982-14

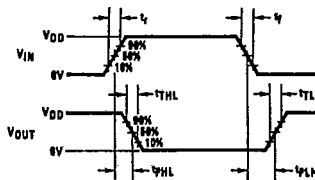

TL/F/5982-15