

TYPES SN5430, SN54H30, SN54L30, SN54LS30, SN54S30, SN7430, SN74H30, SN74LS30, SN74S30 8-INPUT POSITIVE-NAND GATES

REVISED DECEMBER 1983

- Package Options Include Both Plastic and Ceramic Chip Carriers in Addition to Plastic and Ceramic DIPs
- Dependable Texas Instruments Quality and Reliability

description

These devices contain a single 8-input NAND gate.

The SN5430, SN54H30, SN54L30, SN54LS30, and SN54S30 are characterized for operation over the full military range of -55°C to 125°C . The SN7430, SN74H30, SN74LS30, and SN74S30 are characterized for operation from 0°C to 70°C .

FUNCTION TABLE

INPUTS A THRU H	OUTPUT Y
All inputs H	L
One or more inputs L	H

logic diagram

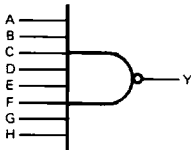

positive logic

$$Y = \overline{A \cdot B \cdot C \cdot D \cdot E \cdot F \cdot G \cdot H} \quad \text{or} \\ Y = \overline{A} + \overline{B} + \overline{C} + \overline{D} + \overline{E} + \overline{F} + \overline{G} + \overline{H}$$

SN5430, SN54H30, SN54L30 . . . J PACKAGE
SN54LS30, SN54S30 . . . J OR W PACKAGE
SN7430, SN74H30 . . . J OR N PACKAGE
SN74LS30, SN74S30 . . . D, J OR N PACKAGE

(TOP VIEW)

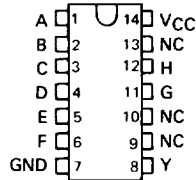

SN5430, SN54H30 . . . W PACKAGE

(TOP VIEW)

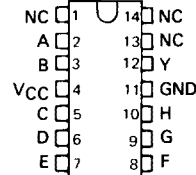

SN54LS30, SN54S30 . . . FK PACKAGE
SN74LS30, SN74S30 . . . FN PACKAGE

(TOP VIEW)

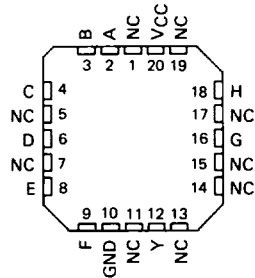

NC - No internal connection

3

TTL DEVICES

PRODUCTION DATA

This document contains information current as of publication date. Products conform to specifications per the terms of Texas Instruments standard warranty. Production processing does not necessarily include testing of all parameters.

TEXAS
INSTRUMENTS

POST OFFICE BOX 225012 • DALLAS, TEXAS 75265

**TYPES SN5430, SN54H30, SN54L30,
SN7430, SN74H30
8-INPUT POSITIVE-NAND GATES**

schematics (each gate)

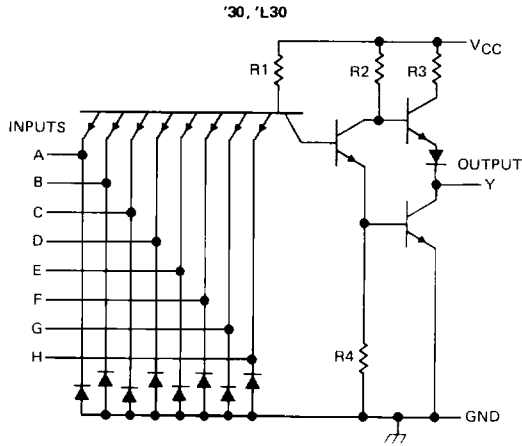

CIRCUIT	R1	R2	R3	R4
'30	4 k Ω	1.6 k Ω	130 Ω	1 k Ω
'L30	40 k Ω	20 k Ω	500 Ω	12 k Ω

Input clamp diodes not on SN54L30 circuit.

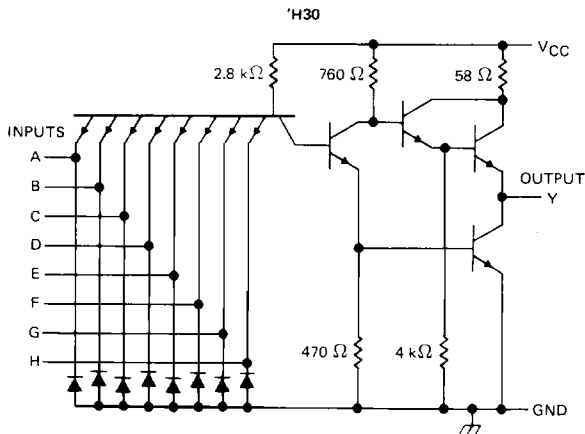

Resistor values shown are nominal.

TYPES SN5430, SN7430

8-INPUT POSITIVE-NAND GATES

recommended operating conditions

	SN5430			SN7430			UNIT
	MIN	NOM	MAX	MIN	NOM	MAX	
V _{CC} Supply voltage	4.5	5	5.5	4.75	5	5.25	V
V _{IH} High-level input voltage	2			2			V
V _{IL} Low-level input voltage			0.8			0.8	V
I _{OH} High-level output current			-0.4			-0.4	mA
I _{OL} Low-level output current			16			16	mA
T _A Operating free-air temperature	-55		125	0		70	°C

electrical characteristics over recommended operating free-air temperature range (unless otherwise noted)

PARAMETER	TEST CONDITIONS †	SN5430		SN7430		UNIT	
		MIN	TYP ‡	MAX	MIN		TYP ‡
V _{IK}	V _{CC} = MIN, I _I = -12 mA		-1.5		-1.5	V	
V _{OH}	V _{CC} = MIN, V _{IL} = 0.8 V, I _{OH} = -0.4 mA	2.4	3.4	2.4	3.4	V	
V _{OL}	V _{CC} = MIN, V _{IH} = 2 V, I _{OL} = 16 mA		0.2	0.4	0.2	0.4	V
I _I	V _{CC} = MAX, V _I = 5.5 V			1		1	mA
I _{IH}	V _{CC} = MAX, V _I = 2.4 V			40		40	μA
I _{IL}	V _{CC} = MAX, V _I = 0.4 V			-1.6		-1.6	mA
I _{OS} §	V _{CC} = MAX	-20		-55	-18	-55	mA
I _{CCH}	V _{CC} = MAX, V _I = 0 V		1	2	1	2	mA
I _{CCL}	V _{CC} = MAX, V _I = 4.5 V		3	6	3	6	mA

† For conditions shown as MIN or MAX, use the appropriate value specified under recommended operating conditions.

‡ All typical values are at V_{CC} = 5 V, T_A = 25°C.

§ Not more than one output should be shorted at a time.

switching characteristics, V_{CC} = 5 V, T_A = 25°C (see note 2)

PARAMETER	FROM (INPUT)	TO (OUTPUT)	TEST CONDITIONS		MIN	TYP	MAX	UNIT
t _{PLH}	Any	Y	R _L = 400 Ω,	C _L = 15 pF		13	22	ns
t _{PHL}						8	15	ns

NOTE 2: See General Information Section for load circuits and voltage waveforms.

3

TTL DEVICES

TYPES SN54H30, SN74H30 8-INPUT POSITIVE-NAND GATES

recommended operating conditions

	SN54H30			SN74H30			UNIT
	MIN	NOM	MAX	MIN	NOM	MAX	
V_{CC} Supply voltage	4.5	5	5.5	4.75	5	5.25	V
V_{IH} High-level input voltage	2			2			V
V_{IL} Low-level input voltage			0.8			0.8	V
I_{OH} High-level output current			-0.5			-0.5	mA
I_{OL} Low-level output current			20			20	mA
T_A Operating free-air temperature	-55		125	0		70	°C

electrical characteristics over recommended operating free-air temperature range (unless otherwise noted)

PARAMETER	TEST CONDITIONS †	MIN	TYP ‡	MAX	UNIT
V_{IK}	$V_{CC} = \text{MIN}, I_I = -8 \text{ mA}$			-1.5	V
V_{OH}	$V_{CC} = \text{MIN}, V_{IL} = 0.8 \text{ V}, I_{OH} = -0.5 \text{ mA}$	2.4	3.5		V
V_{OL}	$V_{CC} = \text{MIN}, V_{IH} = 2 \text{ V}, I_{OL} = 20 \text{ mA}$	0.2	0.4		V
I_I	$V_{CC} = \text{MAX}, V_I = 5.5 \text{ V}$			1	mA
I_{IH}	$V_{CC} = \text{MAX}, V_I = 2.4 \text{ V}$			50	μA
I_{IL}	$V_{CC} = \text{MAX}, V_I = 0.4 \text{ V}$			-2	mA
$I_{OS} §$	$V_{CC} = \text{MAX}$	-40		-100	mA
I_{CCH}	$V_{CC} = \text{MAX}, V_I = 0 \text{ V}$		2.5	4.2	mA
I_{CCL}	$V_{CC} = \text{MAX}, V_I = 4.5 \text{ V}$		6.5	10	mA

† For conditions shown as MIN or MAX, use the appropriate value specified under recommended operating conditions.

‡ All typical values are at $V_{CC} = 5 \text{ V}, T_A = 25^\circ\text{C}$.

§ Not more than one output should be shorted at a time, and the duration of the short-circuit should not exceed one second.

switching characteristics, $V_{CC} = 5 \text{ V}, T_A = 25^\circ\text{C}$ (see note 2)

PARAMETER	FROM (INPUT)	TO (OUTPUT)	TEST CONDITIONS	MIN	TYP	MAX	UNIT
t_{PLH}	Any	Y	$R_L = 280 \Omega, C_L = 25 \text{ pF}$	6.8		10	ns
t_{PHL}				8.9		12	ns

NOTE 2: See General Information Section for load circuits and voltage waveforms.

3

TTL DEVICES

TYPE SN54L30

8-INPUT POSITIVE-NAND GATES

recommended operating conditions

	SN54L30			UNIT
	MIN	NOM	MAX	
V _{CC} Supply voltage	4.5	5	5.5	V
V _{IH} High-level input voltage	2			V
V _{IL} Low-level input voltage			0.7	V
I _{OH} High-level output current			-0.1	mA
I _{OL} Low-level output current			2	mA
T _A Operating free-air temperature	-55		125	°C

electrical characteristics over recommended operating free-air temperature range (unless otherwise noted)

PARAMETER	TEST CONDITIONS †	SN54L30			UNIT
		MIN	TYP ‡	MAX	
V _{OH}	V _{CC} = MIN, V _{IL} = 0.7 V, I _{OH} = -0.1 mA	2.4	3.3		V
V _{OL}	V _{CC} = MIN, V _{IH} = 2 V, I _{OL} = 2 mA		0.15	0.3	V
I _I	V _{CC} = MAX, V _I = 5.5 V			0.1	mA
I _{IH}	V _{CC} = MAX, V _I = 2.4 V			10	µA
I _{IL}	V _{CC} = MAX, V _I = 0.3 V			-0.18	mA
I _{OS} §	V _{CC} = MAX	-3		-15	mA
I _{CCH}	V _{CC} = MAX, V _I = 0 V		0.11	0.33	mA
I _{CCL}	V _{CC} = MAX, V _I = 4.5 V		0.29	0.51	mA

† For conditions shown as MIN or MAX, use the appropriate value specified under recommended operating conditions.

‡ All typical values are at V_{CC} = 5 V, T_A = 25°C.

§ Not more than one output should be shorted at a time.

switching characteristics, V_{CC} = 5 V, T_A = 25°C (see note 2)

PARAMETER	FROM (INPUT)	TO (OUTPUT)	TEST CONDITIONS	MIN	TYP	MAX	UNIT
t _{PLH}	Any	Y	R _L = 4 kΩ, C _L = 50 pF		35	60	ns
t _{PHL}					70	100	ns

NOTE 2: See General Information Section for load circuits and voltage waveforms.

3

TTL DEVICES

TYPES SN54LS30, SN74LS30 8-INPUT POSITIVE-NAND GATES

recommended operating conditions

	SN54LS30			SN74LS30			UNIT
	MIN	NOM	MAX	MIN	NOM	MAX	
V _{CC} Supply voltage	4.5	5	5.5	4.75	5	5.25	V
V _{IH} High-level input voltage	2			2			V
V _{IL} Low-level input voltage			0.7			0.8	V
I _{OH} High-level output current			-0.4			-0.4	mA
I _{OL} Low-level output current			4			8	mA
T _A Operating free-air temperature	-55		125	0		70	°C

electrical characteristics over recommended operating free-air temperature range (unless otherwise noted)

PARAMETER	TEST CONDITIONS †	SN54LS30			SN74LS30			UNIT
		MIN	TYP‡	MAX	MIN	TYP‡	MAX	
V _{IK}	V _{CC} = MIN, I _I = -18 mA			-1.5			-1.5	V
V _{OH}	V _{CC} = MIN, V _{IL} = MAX, I _{OH} = -0.4 mA	2.5	3.4		2.7	3.4		V
V _{OL}	V _{CC} = MIN, V _{IH} = 2 V, I _{OL} = 4 mA		0.25	0.4			0.4	V
	V _{CC} = MIN, V _{IH} = 2 V, I _{OL} = 8 mA					0.25	0.5	
I _I	V _{CC} = MAX, V _I = 7 V			0.1			0.1	mA
I _{IH}	V _{CC} = MAX, V _I = 2.7 V			20			20	μA
I _{IL}	V _{CC} = MAX, V _I = 0.4 V			-0.4			-0.4	mA
I _{OS} §	V _{CC} = MAX	-20		-100	-20		-100	mA
I _{CCH}	V _{CC} = MAX, V _I = 0 V		0.35	0.5		0.35	0.5	mA
I _{CCL}	V _{CC} = MAX, V _I = 4.5 V		0.6	1.1		0.6	1.1	mA

† For conditions shown as MIN or MAX, use the appropriate value specified under recommended operating conditions.

‡ All typical values are at V_{CC} = 5 V, T_A = 25°C

§ Not more than one output should be shorted at a time, and the duration of the short-circuit should not exceed one second.

switching characteristics, V_{CC} = 5 V, T_A = 25°C (see note 2)

PARAMETER	FROM (INPUT)	TO (OUTPUT)	TEST CONDITIONS		MIN	TYP	MAX	UNIT
t _{PLH}	Any	Y	R _L = 2 kΩ,	C _L = 15 pF		8	15	ns
t _{PHL}						13	20	ns

NOTE 2: See General Information Section for load circuits and voltage waveforms

3

TTL DEVICES

TYPES SN54S30, SN74S30

8-INPUT POSITIVE-NAND GATES

recommended operating conditions

	SN54S30			SN74S30			UNIT
	MIN	NOM	MAX	MIN	NOM	MAX	
V _{CC} Supply voltage	4.5	5	5.5	4.75	5	5.25	V
V _{IH} High-level input voltage	2			2			V
V _{IL} Low-level input voltage			0.8			0.8	V
I _{OH} High-level output current			-1			-1	mA
I _{OL} Low-level output current			20			20	mA
T _A Operating free-air temperature	-55		125	0		70	°C

electrical characteristics over recommended operating free-air temperature range (unless otherwise noted)

PARAMETER	TEST CONDITIONS †	SN54S30			SN74S30			UNIT
		MIN	TYP ‡	MAX	MIN	TYP ‡	MAX	
V _{IK}	V _{CC} = MIN, I _I = -18 mA			-1.2			-1.2	V
V _{OH}	V _{CC} = MIN, V _{IL} = 0.8 V, I _{OH} = -1 mA	2.5	3.4		2.7	3.4		V
V _{OL}	V _{CC} = MIN, V _{IH} = 2 V, I _{OL} = 20 mA			0.5			0.5	V
I _I	V _{CC} = MAX, V _I = 5.5 V			1			1	mA
I _{IH}	V _{CC} = MAX, V _I = 2.7 V			50			50	µA
I _{IL}	V _{CC} = MAX, V _I = 0.5 V			-2			-2	mA
I _{OS} §	V _{CC} = MAX	-40		-100	-40		-100	mA
I _{CCH}	V _{CC} = MAX, V _I = 0 V		3	5		3	5	mA
I _{CCL}	V _{CC} = MAX, V _I = 4.5 V		5.5	10		5.5	10	mA

† For conditions shown as MIN or MAX, use the appropriate value specified under recommended operating conditions.

‡ All typical values are at V_{CC} = 5 V, T_A = 25°C.

§ Not more than one output should be shorted at a time, and the duration of the short-circuit should not exceed one second.

switching characteristics, V_{CC} = 5 V, T_A = 25°C (see note 2)

PARAMETER	FROM (INPUT)	TO (OUTPUT)	TEST CONDITIONS	MIN	TYP	MAX	UNIT
t _{PLH}	Any	Y	R _L = 280 Ω, C _L = 15 pF		4	6	ns
t _{PHL}					4.5	7	ns
t _{PLH}			R _L = 280 Ω, C _L = 50 pF		5.5		ns
t _{PHL}					6.5		ns

NOTE 2: See General Information Section for load circuits and voltage waveforms.

3

TTL DEVICES