

Quad two-input AND gate

54F08

ORDERING INFORMATION

DESCRIPTION	ORDER CODE	PACKAGE DESIGNATOR*
14-Pin Ceramic DIP	54F08/BCA	GDIP1-T14
14-Pin Ceramic Flat Pack	54F08/BDA	GDFP1-F14
20-Pin Ceramic LLCC	54F08/B2A	CQCC2-N20

* MIL-STD 1835 or Appendix A of 1995 Military Data Handbook

FUNCTION TABLE

INPUTS		OUTPUT
A	B	Y
L	L	L
L	H	L
H	L	L
H	H	H

H = High voltage level
L = Low voltage level

INPUT AND OUTPUT LOADING AND FAN-OUT TABLE

PINS	DESCRIPTION	54F(U.L.) HIGH/LOW	LOAD VALUE HIGH/LOW
A, B	Inputs	1.0/1.0	20µA/0.6mA
Y	Outputs	50/33	1.0mA/20mA

NOTE: One (1.0) FAST Unit Load (U.L.) is defined as: 20µA in the High state and 0.6mA in the Low state.

ABSOLUTE MAXIMUM RATINGS

(Operation beyond the limits set forth in this table may impair the useful life of the device. Unless otherwise noted these limits are over the operating free-air temperature range.)

SYMBOL	PARAMETER	RATING	UNIT
V _{CC}	Supply voltage range	-0.5 to +7.0	V
V _i	Input voltage range	-0.5 to +7.0	V
I _i	Input current range	-30 to +5	mA
V _O	Voltage applied to output in High output state range	-0.5 to +V _{CC}	V
I _O	Current applied to output in Low output state	40	mA
T _{STG}	Storage temperature range	-65 to +150	°C

PIN CONFIGURATION

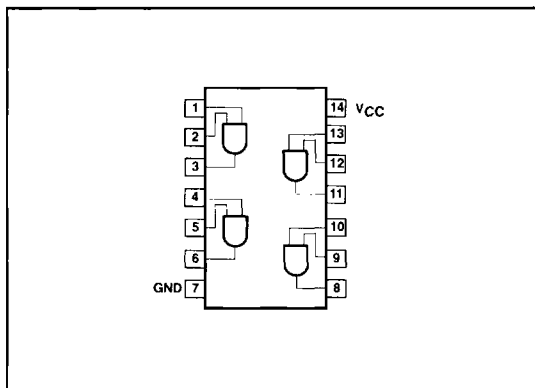

LOGIC SYMBOL

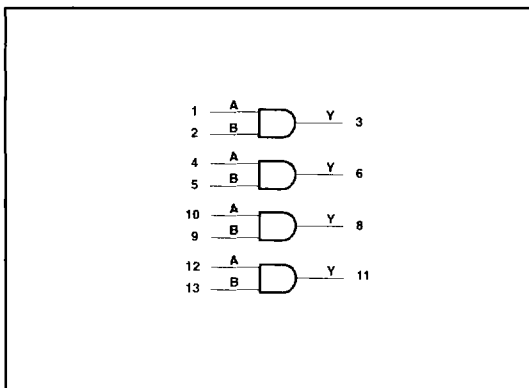

Quad two-input AND gate

54F08

LLCC LEAD CONFIGURATION

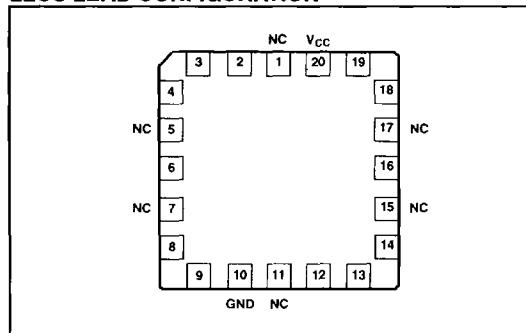

RECOMMENDED OPERATING CONDITIONS

SYMBOL	PARAMETER	LIMITS			UNIT
		MIN	NOM	MAX	
V_{CC}	Supply voltage	4.5	5.0	5.5	V
V_{IH}	High-level input voltage	2.0			V
V_{IL}	Low-level input voltage			0.8	V
I_{IK}	Input clamp current			-18	mA
I_{OH}	High-level output current			-1	mA
I_{OL}	Low-level output current			20	mA
T_A	Operating free-air temperature range	-55		+125	°C

DC ELECTRICAL CHARACTERISTICS

(Over recommended operating free-air temperature unless otherwise noted.)

SYMBOL	PARAMETER	TEST CONDITIONS ¹	LIMITS			UNIT
			MIN	TYP ²	MAX	
V_{OH}	High-level output voltage	$V_{CC} = \text{Min}, V_{IL} = \text{Max}, I_{OH} = \text{Max}, V_{IH} = \text{Min}$	2.5			V
V_{OL}	Low-level output voltage	$V_{CC} = \text{Min}, V_{IL} = \text{Max}, I_{OL} = \text{Max}, V_{IH} = \text{Min}$		0.35	0.50	V
V_{IK}	Input clamp voltage	$V_{CC} = \text{Min}, I_I = I_{IK}$		-0.73	-1.2	V
I_{IH2}	Input current at maximum input voltage	$V_{CC} = \text{Max}, V_I = 7.0V$		5	100	μA
I_{IH1}	High-level input current	$V_{CC} = \text{Max}, V_I = 2.7V$		1	20	μA
I_{IL}	Low-level input current	$V_{CC} = \text{Max}, V_I = 0.5V$		-0.4	-0.6	mA
I_{OS}	Short-circuit output current ³	$V_{CC} = \text{Max}, V_O = 0.0V$	-60	-90	-150	mA
I_{CC}	Supply current (total)	$V_{CC} = \text{Max}$	$V_I \geq 4.0V$	5.5	8.3	mA
			$V_I = \text{GND}$	8.6	12.9	mA

Quad two-input AND gate

54F08

AC ELECTRICAL CHARACTERISTICS

SYMBOL	PARAMETER	TEST CONDITIONS	LIMITS					UNIT
			$T_A = +25^\circ\text{C}, V_{CC} = +5.0\text{V}$ $C_L = 50\text{pF}$ $R_L = 500\Omega$			$T_A = -55^\circ\text{C to } +125^\circ\text{C}$ $V_{CC} = +5.0\text{V} \pm 10\%$ $C_L = 50\text{pF}, R_L = 500\Omega$		
			MIN	TYP	MAX	MIN	MAX	
t_{PLH} t_{PHL}	Propagation delay A, B to Y	Waveform 1	3.0 2.5	4.2 4.0	5.6 5.3	2.5 2.0	7.5 7.5	ns ns

NOTES:

- For conditions shown as Min or Max, use the appropriate value specified under recommended operating conditions for the applicable type and function table for operating mode.
- All typical values are at $V_{CC} = 5\text{V}, T_A = 25^\circ\text{C}$.
- Not more than one output should be shorted at a time. For testing I_{OS} , the use of high-speed test apparatus and/or sample-and-hold techniques are preferable in order to minimize internal heating and more accurately reflect operational values. Otherwise, prolonged shorting of a High output may raise the chip temperature well above normal and thereby cause invalid readings in other parameter tests. In any sequence of parameter tests, I_{OS} tests should be performed last.

AC WAVEFORM

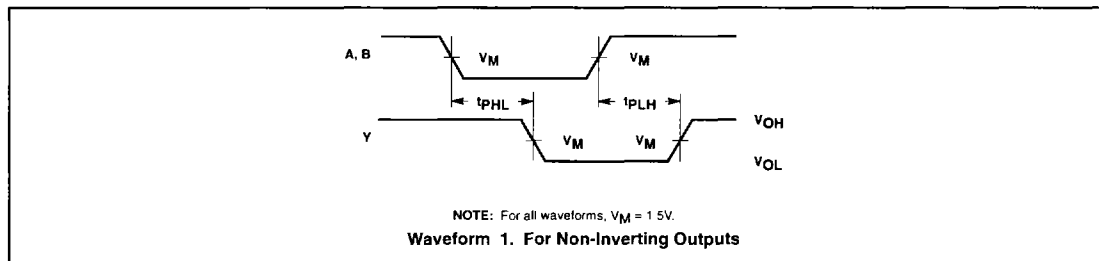

TEST CIRCUIT AND WAVEFORM

