

DM64ALS08/DM74ALS08 Quad 2-Input AND Gate

General Description

This device contains four independent gates, each of which performs the logic AND function.

The DM64ALS08 version features the same performance as the standard version DM74ALS08 with a guarantee over an extended temperature range (-40°C to $+85^{\circ}\text{C}$).

Features

- Switching specifications at 50 pF
- Switching specifications guaranteed over full temperature and V_{CC} range
- Advanced oxide-isolated, ion-implanted Schottky TTL process
- Functionally and pin for pin compatible with Schottky and low power Schottky TTL counterpart
- Improved AC performance over Schottky and low power Schottky counterparts
- DM64ALS08 guaranteed over extended temperature -40°C to $+85^{\circ}\text{C}$

Connection Diagram

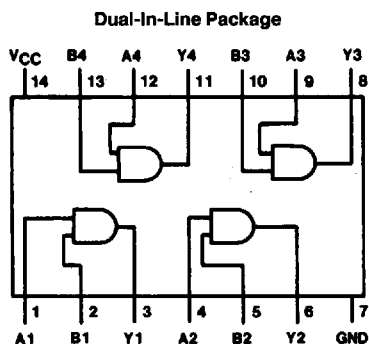

TL/F/6271-1

Order Number DM64ALS08M, DM64ALS08N, DM74ALS08M, DM74ALS08N or DM74ALS08SJ
See NS Package Number M14A, M14D or N14A

Function Table

$$Y = AB$$

Inputs		Output
A	B	Y
L	L	L
L	H	L
H	L	L
H	H	H

H = High Logic Level

L = Low Logic Level

Absolute Maximum Ratings

Supply Voltage	7V
Input Voltage	7V
Operating Free Air Temperature Range	
DM74ALS	0°C to +70°C
DM64ALS	-40°C to +85°C
Storage Temperature Range	-65°C to +150°C
Typical θ_{JA}	
N Package	89°C/W
M Package	120°C/W

Note: The "Absolute Maximum Ratings" are those values beyond which the safety of the device cannot be guaranteed. The device should not be operated at these limits. The parametric values defined in the "Electrical Characteristics" table are not guaranteed at the absolute maximum ratings. The "Recommended Operating Conditions" table will define the conditions for actual device operation.

Recommended Operating Conditions

Symbol	Parameter	DM64ALS08			DM74ALS08			Units
		Min	Nom	Max	Min	Nom	Max	
V_{CC}	Supply Voltage	4.5	5	5.5	4.5	5	5.5	V
V_{IH}	High Level Input Voltage	2			2			V
V_{IL}	Low Level Input Voltage			0.8			0.8	V
I_{OH}	High Level Output Current			-0.4			-0.4	mA
I_{OL}	Low Level Output Current			8			8	mA
T_A	Free Air Operating Temperature	-40		85	0		70	°C

Electrical Characteristics

over recommended operating free air temperature range. All typical values are measured at $V_{CC} = 5V$, $T_A = 25^\circ C$.

Symbol	Parameter	Conditions	Min	Typ	Max	Units
V_{IK}	Input Clamp Voltage	$V_{CC} = 4.5V$, $I_I = -18 mA$			-1.5	V
V_{OH}	High Level Output Voltage	$I_{OH} = -0.4 mA$ $V_{CC} = 4.5V$ to $5.5V$	$V_{CC} - 2$			V
V_{OL}	Low Level Output Voltage	$V_{CC} = 4.5V$	$I_{OL} = 4 mA$	0.25	0.4	V
			$I_{OL} = 8 mA$	0.35	0.5	V
I_I	Input Current @ Max. Input Voltage	$V_{CC} = 5.5V$, $V_{IH} = 7V$			0.1	mA
I_{IH}	High Level Input Current	$V_{CC} = 5.5V$, $V_{IH} = 2.7V$			20	μA
I_{IL}	Low Level Input Current	$V_{CC} = 5.5V$, $V_{IL} = 0.4V$			-0.1	mA
I_O	Output Drive Current	$V_{CC} = 5.5V$	$V_O = 2.25V$	-30	-112	mA
I_{CC}	Supply Current	$V_{CC} = 5.5V$	Outputs High	1.3	2.4	mA
			Outputs Low	2.2	4	mA

Switching Characteristics

over recommended operating free air temperature range (Note 1).

Symbol	Parameter	Conditions	DM64ALS08		DM74ALS08		Units
			Min	Max	Min	Max	
t_{PLH}	Propagation Delay Time Low to High Level Output	$V_{CC} = 4.5V$ to $5.5V$ $R_L = 500\Omega$ $C_L = 50 pF$	4	14	4	14	ns
t_{PHL}	Propagation Delay Time High to Low Level Output		3	10	3	10	ns

Note 1: See Section 5 for test waveforms and output load.