

Product Features

- Functionally compatible with FCT3, LVT, and 74 series 16374 families of products
- 3-state outputs
- 5V Tolerant inputs and outputs
- 2.0V-3.6V V_{CC} supply operation
- Balanced sink and source output drives (24mA)
- Low ground bounce outputs
- Power down High Impedance inputs and outputs
- Supports live insertion
- ESD Protection exceeds 2000V, Human Body Model
200V, Machine Model
- Packaging (Pb-free & Green available):
–48-pin 240-mil wide plastic TSSOP (A)

Product Description

The PI74LCX16374 is a 16-bit octal register designed with 16 D-type flip-flops with a buffered common clock and 3-state outputs. The Output Enable (\overline{xOE}) and clock ($xCLK$) controls are organized to operate as two 8-bit registers or one 16-bit register. When \overline{OE} is HIGH, the outputs are in the high impedance state. Input data meeting the setup and hold time requirements of the D inputs is transferred to the O outputs on the LOW-to-HIGH transition of the clock input.

The PI74LCX16374 can be driven from either 3.3V or 5.0V devices allowing this device to be used as a translator in a mixed 3.3/5.0V system.

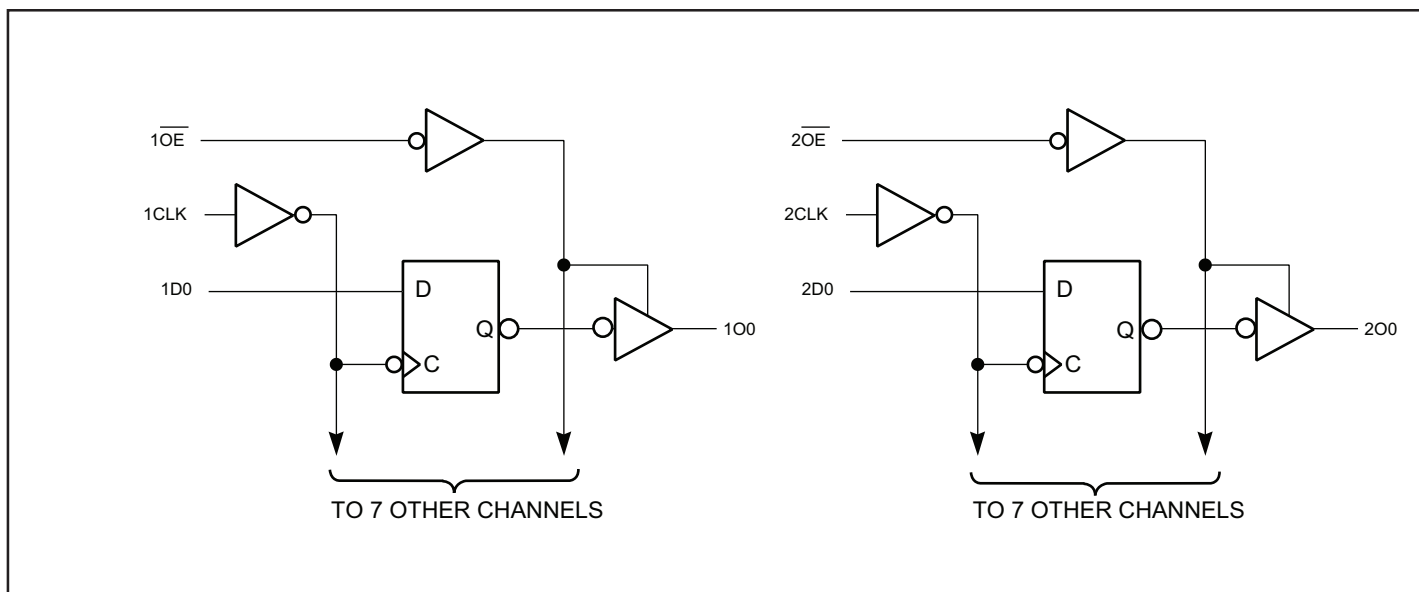
Logic Block Diagram

Product Pin Description

Pin Name	Description
\overline{xOE}	3-State Output Enable Inputs (Active LOW)
xCLK	Clock Inputs
xDx	Data Inputs
xOx	3-State Outputs
GND	Ground
Vcc	Power

Truth Table

Function	Inputs ⁽¹⁾			Outputs ⁽¹⁾
	xDx	xCLK	\overline{xOE}	xOx
High-Z	X	L	H	Z
	X	H	H	Z
Load Register	L	↑	L	L
	H	↑	L	H
	L	↑	H	Z
	H	↑	H	Z
	X	H or L	L	O ₀

Product Pin Configuration

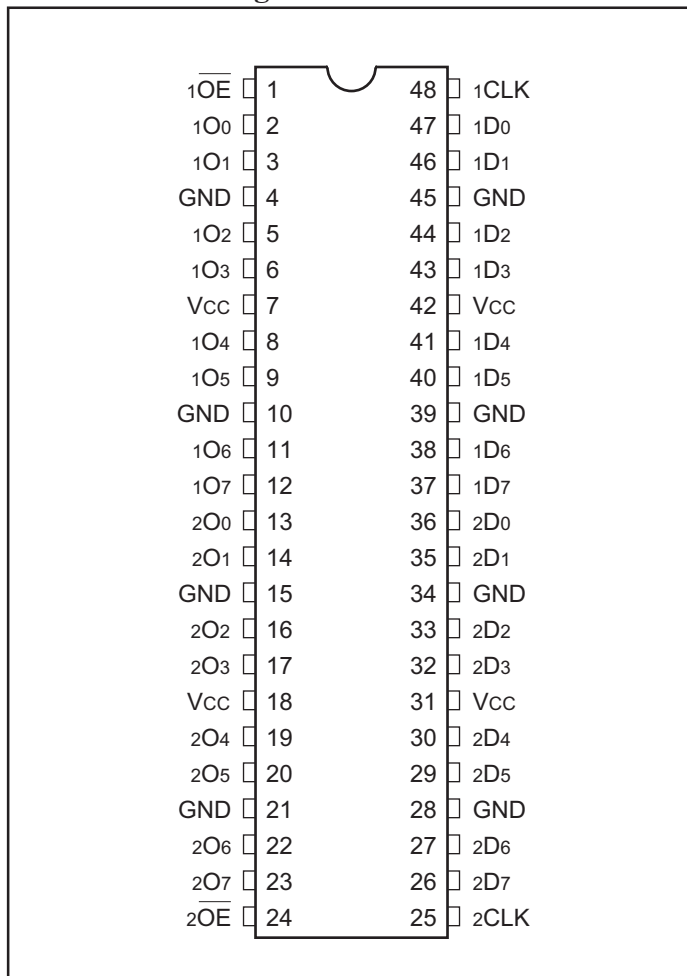

Notes:

- H = High Voltage Level, X = Don't Care,
L = Low Voltage Level, Z = High Impedance

Maximum Ratings

(Above which the useful life may be impaired. For user guidelines, not tested.)

Storage Temperature	-65°C to +150°C
Ambient Temperature with Power Applied	-40°C to +85°C
Supply Voltage to Ground Potential (Inputs & Vcc Only)	-0.5V to +7.0V
Supply Voltage to Ground Potential (Outputs & D/O Only)	-0.5V to +7.0V
DC Input Voltage	-0.5V to +7.0V
DC Output Current	120 mA
Power Dissipation	1.0W

Note:

Stresses greater than those listed under MAXIMUM RATINGS may cause permanent damage to the device. This is a stress rating only and functional operation of the device at these or any other conditions above those indicated in the operational sections of this specification is not implied. Exposure to absolute maximum rating conditions for extended periods may affect reliability.

Recommended Operating Conditions

Symbol	Parameter	Min.	Max.	Units		
Vcc	Supply Voltage	Operating	2.0	3.6	V	
		Data Retention	1.5	3.6		
Vi	Input Voltage	0	5.5			
Vo	Output Voltage	HIGH or LOW State	0	Vcc		
		TRI-State	0	5.5		
IOH/IOL	Output Current	Vcc = 3.0V-3.6V		±24		mA
		Vcc = 2.7V		±12		
TA	Free-Air Operating Temperature	-40	+85	°C		
Dt/DV	Input Edge Rate	V = 0.8V-2.0V, Vcc = 3.0V		0	10	ns/V

DC Electrical Characteristics (Over the Operating Range, $T_A = -40^{\circ}\text{C}$ to $+85^{\circ}\text{C}$, $V_{CC} = 2.7\text{V}$ to 3.6V)

Parameters	Description	Test Conditions ⁽¹⁾		Min.	Typ ⁽²⁾	Max.	Units
V_{IH}	Input HIGH Voltage	Guaranteed Logic HIGH Level		2.0			V
V_{IL}	Input LOW Voltage	Guaranteed Logic LOW Level				0.8	
V_{OH}	Output HIGH Voltage	$V_{CC} = 2.7-3.6$	$I_{OH} = -0.1\text{ mA}$	$V_{CC}-0.2$			
		$V_{CC} = 2.7$	$I_{OH} = -12\text{ mA}$	2.2			
		$V_{CC} = 3.0$	$I_{OH} = -18\text{ mA}$	2.4			
			$I_{OH} = -24\text{ mA}$	2.2			
V_{OL}	Output LOW Voltage	$V_{CC} = 2.7-3.6$	$I_{OL} = 0.1\text{ mA}$			0.2	
		$V_{CC} = 2.7$	$I_{OL} = 12\text{ mA}$			0.4	
		$V_{CC} = 3.0$	$I_{OL} = 16\text{ mA}$			0.4	
			$I_{OL} = 24\text{ mA}$			0.55	
V_{IK}	Clamp Diode Voltage	$V_{CC} = \text{Min.}, I_{IN} = -18\text{ mA}$			-0.7	-1.2	
I_I	Input Leakage Current	$0 \leq V_I \leq 5.5\text{V}$	$V_{CC} = 2.7-3.6$			± 5	μA
I_{OZ}	Tri-State Output Leakage	$0 \leq V_O \leq 5.5\text{V}$ $V_I = V_{IH}$ or V_{IL}	$V_{CC} = 2.7-3.6$			± 5	
I_{OFF}	Power Down Disable	$V_{CC} = 0\text{V}, V_{IN}$ or $V_{OUT} \leq 5.5\text{V}$				10	
I_{CC}	Quiescent Power Supply Current	$V_{CC} = \text{Max.}$	$V_{IN} = \text{GND}$ or V_{CC}		0.1	10	
DI_{CC}	Quiescent Power Supply Current TTL Inputs HIGH	$V_{CC} = \text{Max.}$	$V_{IN} = V_{CC}$ $-0.6\text{V}^{(3)}$			500	

Notes:

1. For Max. or Min. conditions, use appropriate value specified under Electrical Characteristics for the applicable device type.
2. Typical values are at $V_{CC} = 3.3\text{V}$, $+25^{\circ}\text{C}$ ambient.
3. Per TTL driven input; all other inputs at V_{CC} or GND .

Capacitance

Parameters	Description	Test Conditions	Typical	Units
C_{IN}	Input Capacitance	$V_{CC} = \text{Open}, V_I = 0\text{V}$ or V_{CC}	7	pF
C_{OUT}	Output Capacitance	$V_{CC} = 3.3\text{V}, V_I = 0\text{V}$ or V_{CC}	8	
C_{PD}	Power Dissipation Capacitance	$V_{CC} = 3.3\text{V}, V_I = 0\text{V}$ or $V_{CC}, F = 10\text{ MHz}$	20	

Switching Characteristics over Operating Range

Parameters	Description	Conditions	V _{CC} = 3.3V ± 0.3V		V _{CC} = 2.7V		Units
			Min.	Max.	Min.	Max.	
f _{MAX}	Maximum Clock Frequency	C _L = 50pF R _L = 500Ω	170				MHz
t _{PHL} t _{PLH}	Propagation Delay CP to On		1.5	6.2	1.5	6.5	ns
t _{PZL} t _{PZH}	Output Enable Time		1.5	6.1	1.5	6.3	
t _{PLZ} t _{PHZ}	Output Disable Time		1.5	6.0	1.5	6.2	
t _s	Setup Time		2.5		2.5		
t _H	Hold Time		1.5		1.5		
t _w	Pulse Width		3.0		3.0		
t _{SK(O)}	Output to Output Skew ⁽¹⁾			1.0			

Notes:

1. Skew between any two outputs, of the same package, switching in the same direction.

Dynamic Switching Characteristics (T_A = +25°C)

Parameters	Description	Test Conditions ⁽¹⁾	Typical	Units
V _{OLP}	Dynamic LOW Peak Voltage	V _{CC} = 3.3V, C _L = 50pF V _{IH} = 3.3V, V _{IL} = 0V	0.8	V
V _{OLV}	Dynamic LOW Valley Voltage	V _{CC} = 3.3V, C _L = 50pF V _{IH} = 3.3V, V _{IL} = 0V		

Notes:

1. Measured with n-1 outputs switching from High-to-Low or Low-to-High. The remaining output is measured in the LOW state.

Packaging Mechanical: 48-Pin TSSOP (A)

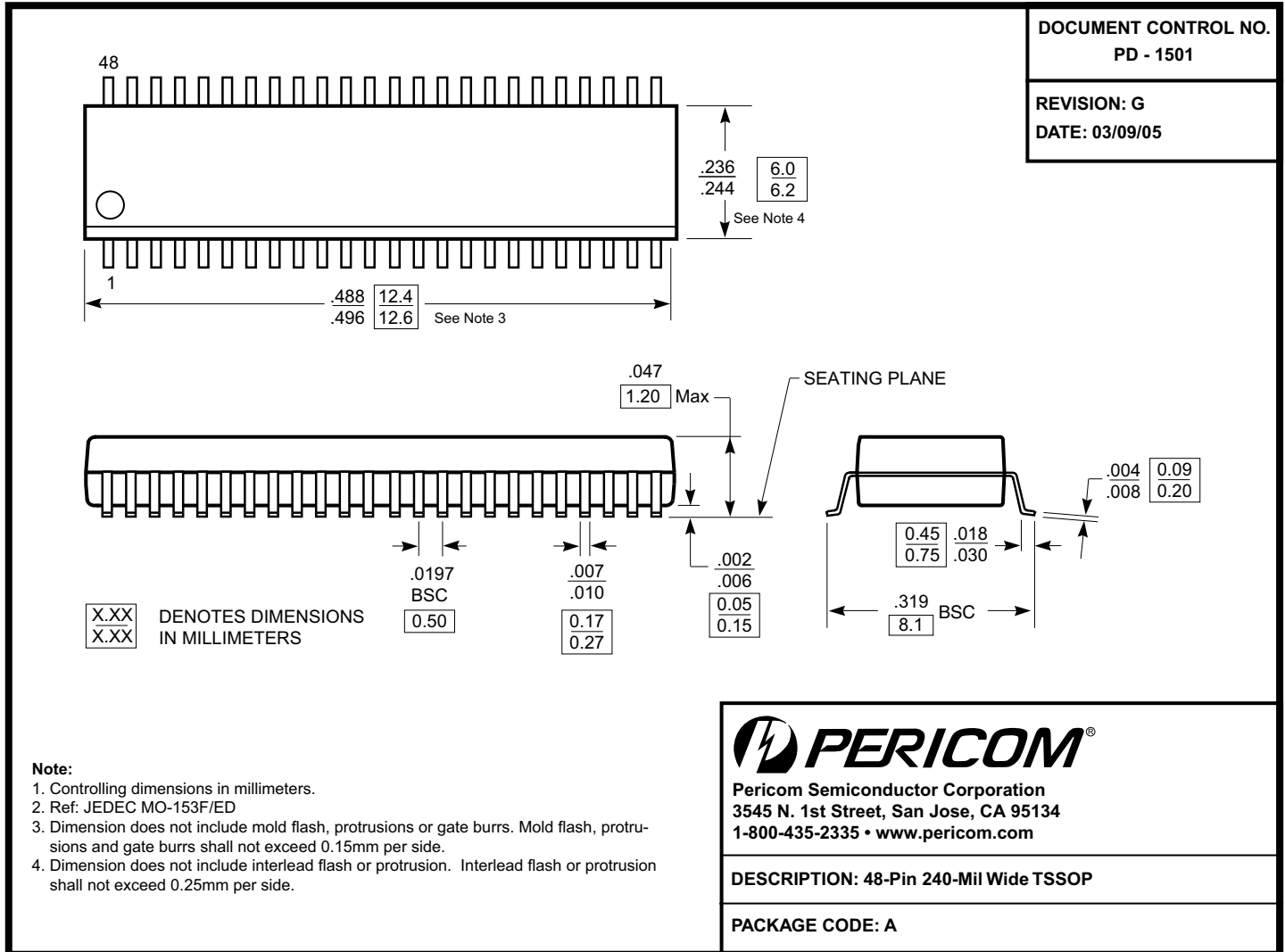

Ordering Information

Ordering Code	Package Type	Package Description
PI74LCX16374AE	A	Pb-free & Green, 48-Pin 240-mil wide Plastic TSSOP (A)

Notes:

- Thermal characteristics can be found on the company web site at www.pericom.com/packaging/
- E = Pb-free & Green
- Adding an X suffix = Tape/Reel