

SN54LVT125, SN74LVT125 3.3-V ABT QUADRUPLE BUS BUFFERS WITH 3-STATE OUTPUTS

SCBS133D – MAY 1992 – REVISED JULY 1995

- State-of-the-Art Advanced BiCMOS Technology (ABT) Design for 3.3-V Operation and Low-Static Power Dissipation
- Support Mixed-Mode Signal Operation (5-V Input and Output Voltages With 3.3-V V_{CC})
- Support Unregulated Battery Operation Down to 2.7 V
- Typical V_{OLP} (Output Ground Bounce) < 0.8 V at $V_{CC} = 3.3$ V, $T_A = 25^\circ\text{C}$
- ESD Protection Exceeds 2000 V Per MIL-STD-883C, Method 3015; Exceeds 200 V Using Machine Model ($C = 200$ pF, $R = 0$)
- Latch-Up Performance Exceeds 500 mA Per JEDEC Standard JESD-17
- Bus-Hold Data Inputs Eliminate the Need for External Pullup Resistors
- Support Live Insertion
- Package Options Include Plastic Small-Outline (D), Shrink Small-Outline (DB), and Thin Shrink Small-Outline (PW) Packages, Ceramic Chip Carriers (FK), and Ceramic (J) DIPs

SN54LVT125 . . . J PACKAGE
SN74LVT125 . . . D, DB, OR PW PACKAGE
(TOP VIEW)

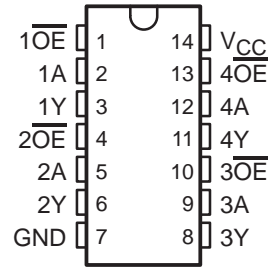

SN54LVT125 . . . FK PACKAGE
(TOP VIEW)

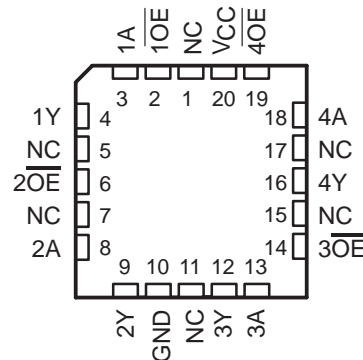

NC – No internal connection

description

These bus buffers are designed specifically for low-voltage (3.3-V) V_{CC} operation, but with the capability to provide a TTL interface to a 5-V system environment.

The 'LVT125 feature independent line drivers with 3-state outputs. Each output is in the high-impedance state when the associated output-enable (\overline{OE}) input is high.

Active bus-hold circuitry is provided to hold unused or floating data inputs at a valid logic level.

To ensure the high-impedance state during power up or power down, \overline{OE} should be tied to V_{CC} through a pullup resistor; the minimum value of the resistor is determined by the current-sinking capability of the driver.

The SN74LVT125 is available in TI's shrink small-outline package (DB), which provides the same I/O pin count and functionality of standard small-outline packages in less than half the printed-circuit-board area.

The SN54LVT125 is characterized for operation over the full military temperature range of -55°C to 125°C . The SN74LVT125 is characterized for operation from -40°C to 85°C .



Please be aware that an important notice concerning availability, standard warranty, and use in critical applications of Texas Instruments semiconductor products and disclaimers thereto appears at the end of this data sheet.

UNLESS OTHERWISE NOTED this document contains PRODUCTION DATA information current as of publication date. Products conform to specifications per the terms of Texas Instruments standard warranty. Production processing does not necessarily include testing of all parameters.

 **TEXAS
INSTRUMENTS**

POST OFFICE BOX 655303 • DALLAS, TEXAS 75265

Copyright © 1995, Texas Instruments Incorporated

SN54LVT125, SN74LVT125

3.3-V ABT QUADRUPLE BUS BUFFERS

WITH 3-STATE OUTPUTS

SCBS133D – MAY 1992 – REVISED JULY 1995

FUNCTION TABLE
(each buffer)

INPUTS		OUTPUT
\overline{OE}	A	Y
L	H	H
L	L	L
H	X	Z

logic symbol†

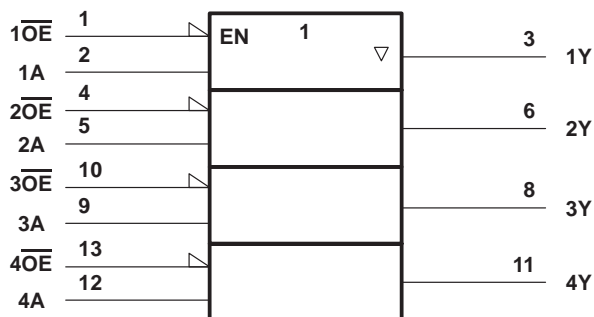

† This symbol is in accordance with ANSI/IEEE Std 91-1984 and IEC Publication 617-12.

logic diagram (positive logic)

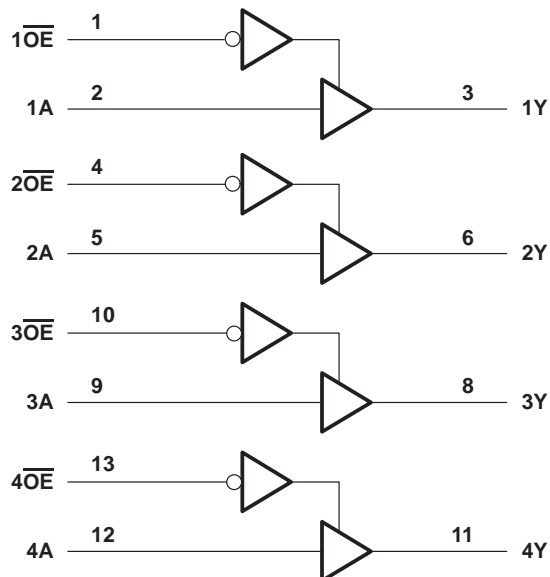

Pin numbers shown are for the D, DB, J, and PW packages.

absolute maximum ratings over operating free-air temperature range (unless otherwise noted)‡

Supply voltage range, V_{CC}	-0.5 V to 4.6 V
Input voltage range, V_I (see Note 1)	-0.5 V to 7 V
Voltage range applied to any output in the high state or power-off state, V_O (see Note 1)	-0.5 V to 7 V
Current into any output in the low state, I_O : SN54LVT125	96 mA
SN74LVT125	128 mA
Current into any output in the high state, I_O (see Note 2): SN54LVT125	48 mA
SN74LVT125	64 mA
Input clamp current, I_{IK} ($V_I < 0$)	-50 mA
Output clamp current, I_{OK} ($V_O < 0$)	-50 mA
Maximum power dissipation at $T_A = 55^\circ\text{C}$ (in still air) (see Note 3): D package	1.25 W
DB or PW package	0.5 W
Storage temperature range, T_{stg}	-65°C to 150°C

‡ Stresses beyond those listed under "absolute maximum ratings" may cause permanent damage to the device. These are stress ratings only, and functional operation of the device at these or any other conditions beyond those indicated under "recommended operating conditions" is not implied. Exposure to absolute-maximum-rated conditions for extended periods may affect device reliability.

- NOTES:
1. The input and output negative-voltage ratings may be exceeded if the input and output clamp-current ratings are observed.
 2. This current flows only when the output is in the high state and $V_O > V_{CC}$.
 3. The maximum package power dissipation is calculated using a junction temperature of 150°C and a board trace length of 750 mils. For more information, refer to the *Package Thermal Considerations* application note in the 1994 *ABT Advanced BiCMOS Technology Data Book*, literature number SCBD002B.

SN54LVT125, SN74LVT125

3.3-V ABT QUADRUPLE BUS BUFFERS

WITH 3-STATE OUTPUTS

SCBS133D – MAY 1992 – REVISED JULY 1995

recommended operating conditions (see Note 4)

		SN54LVT125		SN74LVT125		UNIT
		MIN	MAX	MIN	MAX	
V_{CC}	Supply voltage	2.7	3.6	2.7	3.6	V
V_{IH}	High-level input voltage	2		2		V
V_{IL}	Low-level input voltage		0.8		0.8	V
V_I	Input voltage		5.5		5.5	V
I_{OH}	High-level output current		-24		-32	mA
I_{OL}	Low-level output current		48		64	mA
$\Delta t/\Delta v$	Input transition rise or fall rate	Outputs enabled		10	10	ns/V
T_A	Operating free-air temperature	-55	125	-40	85	°C

NOTE 4: Unused control inputs must be held high or low to prevent them from floating.

electrical characteristics over recommended operating free-air temperature range (unless otherwise noted)

PARAMETER	TEST CONDITIONS		SN54LVT125		SN74LVT125		UNIT
			MIN	TYP†	MAX	MIN	
V_{IK}	$V_{CC} = 2.7\text{ V}$, $I_I = -18\text{ mA}$				-1.2		V
V_{OH}	$V_{CC} = \text{MIN to MAX}^\ddagger$, $I_{OH} = -100\ \mu\text{A}$		$V_{CC} - 0.2$		$V_{CC} - 0.2$		V
	$V_{CC} = 2.7\text{ V}$, $I_{OH} = -8\text{ mA}$		2.4		2.4		
	$V_{CC} = 3\text{ V}$	$I_{OH} = -24\text{ mA}$	2				
V_{OL}	$V_{CC} = 2.7\text{ V}$	$I_{OL} = 100\ \mu\text{A}$			0.2		V
		$I_{OL} = 24\text{ mA}$			0.5		
	$V_{CC} = 3\text{ V}$	$I_{OL} = 16\text{ mA}$			0.4		
		$I_{OL} = 32\text{ mA}$			0.5		
		$I_{OL} = 48\text{ mA}$			0.55		
		$I_{OL} = 64\text{ mA}$			0.55		
I_I	$V_{CC} = 0\text{ or MAX}^\ddagger$, $V_I = 5.5\text{ V}$				10		μA
	$V_{CC} = 3.6\text{ V}$	$V_I = V_{CC}\text{ or GND}$	Control inputs	± 1			
		$V_I = V_{CC}$	Data inputs	1			
		$V_I = 0$		-5			
I_{off}	$V_{CC} = 0$, $V_I\text{ or }V_O = 0\text{ to }4.5\text{ V}$				± 100		
$I_I(\text{hold})$	$V_{CC} = 3\text{ V}$	$V_I = 0.8\text{ V}$	Data inputs	75		μA	
		$V_I = 2\text{ V}$		-75			
I_{OZH}	$V_{CC} = 3.6\text{ V}$, $V_O = 3\text{ V}$				5		
I_{OZL}	$V_{CC} = 3.6\text{ V}$, $V_O = 0.5\text{ V}$				-5		
I_{CC}	$V_{CC} = 3.6\text{ V}$, $V_I = V_{CC}\text{ or GND}$	$I_O = 0$,	Outputs high	0.12	0.19	0.12	0.19
			Outputs low	4.5	7	4.5	7
			Outputs disabled	0.12	0.19	0.12	0.19
ΔI_{CC}^\S	$V_{CC} = 3\text{ V to }3.6\text{ V}$, One input at $V_{CC} - 0.6\text{ V}$, Other inputs at $V_{CC}\text{ or GND}$				0.3		
C_i	$V_I = 3\text{ V or }0$				4		
C_o	$V_O = 3\text{ V or }0$				8		

† All typical values are at $V_{CC} = 3.3\text{ V}$, $T_A = 25^\circ\text{C}$.

‡ For conditions shown as MIN or MAX, use the appropriate value specified under recommended operating conditions.

§ This is the increase in supply current for each input that is at the specified TTL voltage level rather than V_{CC} or GND.

PRODUCT PREVIEW information concerns products in the formative or design phase of development. Characteristic data and other specifications are design goals. Texas Instruments reserves the right to change or discontinue these products without notice.



SN54LVT125, SN74LVT125
3.3-V ABT QUADRUPLE BUS BUFFERS
WITH 3-STATE OUTPUTS

SCBS133D – MAY 1992 – REVISED JULY 1995

switching characteristics over recommended operating free-air temperature range, $C_L = 50 \text{ pF}$
(unless otherwise noted) (see Figure 1)

PARAMETER	FROM (INPUT)	TO (OUTPUT)	SN54LVT125				SN74LVT125				UNIT	
			$V_{CC} = 3.3 \text{ V}$ $\pm 0.3 \text{ V}$		$V_{CC} = 2.7 \text{ V}$		$V_{CC} = 3.3 \text{ V}$ $\pm 0.3 \text{ V}$			$V_{CC} = 2.7 \text{ V}$		
			MIN	MAX	MIN	MAX	MIN	TYP†	MAX	MIN		MAX
t_{PLH}	A	Y	1	4.2		4.7	1	2.7	4		4.5	ns
t_{PHL}			1	4.1		5.1	1	2.9	3.9		4.9	
t_{PZH}	\overline{OE}	Y	1	4.9		6.2	1	3.4	4.7		6	ns
t_{PZL}			1.1	4.9		6.7	1.1	3.4	4.7		6.5	
t_{PHZ}	\overline{OE}	Y	1.8	5.3		5.9	1.8	3.7	5.1		5.7	ns
t_{PLZ}			1.3	4.7		4.2	1.3	2.6	4.5		4	

† All typical values are at $V_{CC} = 3.3 \text{ V}$, $T_A = 25^\circ\text{C}$.

PARAMETER MEASUREMENT INFORMATION

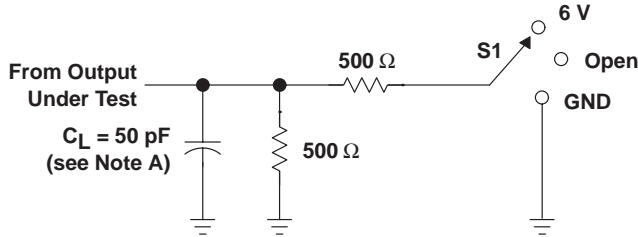

TEST	S1
t_{PLH}/t_{PHL}	Open
t_{PLZ}/t_{PZL}	6 V
t_{PHZ}/t_{PZH}	GND

LOAD CIRCUIT FOR OUTPUTS

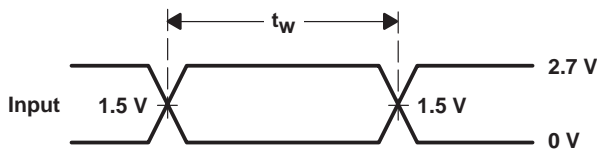

VOLTAGE WAVEFORMS
PULSE DURATION

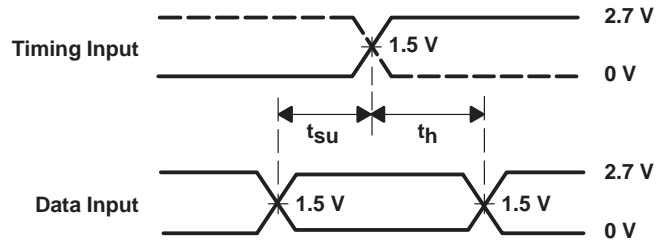

VOLTAGE WAVEFORMS
SETUP AND HOLD TIMES

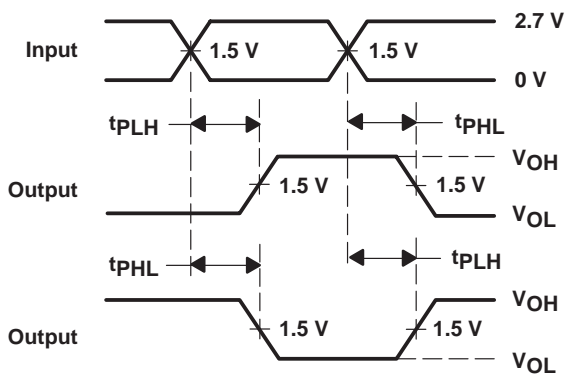

VOLTAGE WAVEFORMS
PROPAGATION DELAY TIMES
INVERTING AND NONINVERTING OUTPUTS

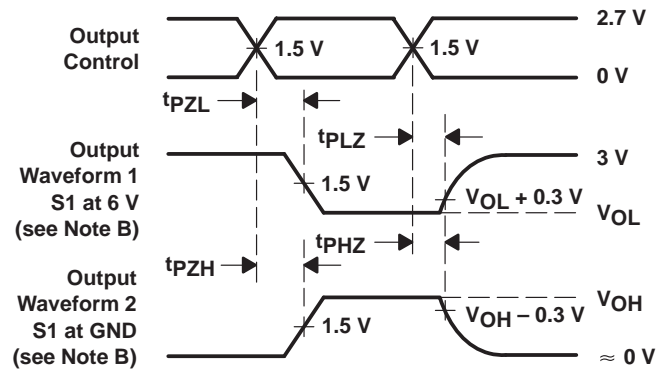

VOLTAGE WAVEFORMS
ENABLE AND DISABLE TIMES
LOW- AND HIGH-LEVEL ENABLING

- NOTES: A. C_L includes probe and jig capacitance.
 B. Waveform 1 is for an output with internal conditions such that the output is low except when disabled by the output control. Waveform 2 is for an output with internal conditions such that the output is high except when disabled by the output control.
 C. All input pulses are supplied by generators having the following characteristics: $PRR \leq 10$ MHz, $Z_O = 50 \Omega$, $t_r \leq 2.5$ ns, $t_f \leq 2.5$ ns.
 D. The outputs are measured one at a time with one transition per measurement.

Figure 1. Load Circuit and Voltage Waveforms

IMPORTANT NOTICE

Texas Instruments and its subsidiaries (TI) reserve the right to make changes to their products or to discontinue any product or service without notice, and advise customers to obtain the latest version of relevant information to verify, before placing orders, that information being relied on is current and complete. All products are sold subject to the terms and conditions of sale supplied at the time of order acknowledgement, including those pertaining to warranty, patent infringement, and limitation of liability.

TI warrants performance of its semiconductor products to the specifications applicable at the time of sale in accordance with TI's standard warranty. Testing and other quality control techniques are utilized to the extent TI deems necessary to support this warranty. Specific testing of all parameters of each device is not necessarily performed, except those mandated by government requirements.

CERTAIN APPLICATIONS USING SEMICONDUCTOR PRODUCTS MAY INVOLVE POTENTIAL RISKS OF DEATH, PERSONAL INJURY, OR SEVERE PROPERTY OR ENVIRONMENTAL DAMAGE ("CRITICAL APPLICATIONS"). TI SEMICONDUCTOR PRODUCTS ARE NOT DESIGNED, AUTHORIZED, OR WARRANTED TO BE SUITABLE FOR USE IN LIFE-SUPPORT DEVICES OR SYSTEMS OR OTHER CRITICAL APPLICATIONS. INCLUSION OF TI PRODUCTS IN SUCH APPLICATIONS IS UNDERSTOOD TO BE FULLY AT THE CUSTOMER'S RISK.

In order to minimize risks associated with the customer's applications, adequate design and operating safeguards must be provided by the customer to minimize inherent or procedural hazards.

TI assumes no liability for applications assistance or customer product design. TI does not warrant or represent that any license, either express or implied, is granted under any patent right, copyright, mask work right, or other intellectual property right of TI covering or relating to any combination, machine, or process in which such semiconductor products or services might be or are used. TI's publication of information regarding any third party's products or services does not constitute TI's approval, warranty or endorsement thereof.

PRODUCT FOLDER | PRODUCT INFO:
 [REPLACEMENT DEVICES](#) |
 [FEATURES](#) |
 [DESCRIPTION](#) |
 [DATASHEETS](#) |
 [PRICING/AVAILABILITY/PKG](#) |
 [SAMPLES](#) |
 [APPLICATION NOTES](#) |
 [RELATED DOCUMENTS](#)

PRODUCT SUPPORT: [TRAINING](#)

SN74LVT125, 3.3-V ABT Quadruple Bus Buffers With 3-State Outputs

DEVICE STATUS: **ACTIVE**

RECOMMENDED REPLACEMENT DEVICES

Part Number	Comments
SN74LVT125	The device has the SAME FUNCTIONALITY and PINOUT as the compared device but is NOT an exact equivalent. Device Revision (PCN Number: PCN 5287C)

PARAMETER NAME	SN74LVT125
Voltage Nodes (V)	3.3, 2.7
Vcc range (V)	2.7 to 3.6
Input Level	TTL/CMOS
Output Level	LVTTL
Output Drive (mA)	-32/64
tpd max (ns)	4
Static Current	3.6

FEATURES

[▲Back to Top](#)

- State-of-the-Art Advanced BiCMOS Technology (ABT) Design for 3.3-V Operation and Low-Static Power Dissipation
- Support Mixed-Mode Signal Operation (5-V Input and Output Voltages With 3.3-V V_{CC})
- Support Unregulated Battery Operation Down to 2.7 V
- Typical V_{OLP} (Output Ground Bounce) < 0.8 V at $V_{CC} = 3.3$ V, $T_A = 25^\circ\text{C}$
- ESD Protection Exceeds 2000 V Per MIL-STD-883C, Method 3015; Exceeds 200 V Using Machine Model ($C = 200$ pF, $R = 0$)
- Latch-Up Performance Exceeds 500 mA Per JEDEC Standard JESD-17
- Bus-Hold Data Inputs Eliminate the Need for External Pullup Resistors
- Support Live Insertion
- Package Options Include Plastic Small-Outline (D), Shrink Small-Outline (DB), and Thin Shrink Small-Outline (PW) Packages, Ceramic Chip Carriers (FK), and Ceramic (J) DIPs

DESCRIPTION

[▲Back to Top](#)

These bus buffers are designed specifically for low-voltage (3.3-V) V_{CC} operation, but with the capability to provide a TTL interface to a 5-V system environment.

The LVT125 feature independent line drivers with 3-state outputs. Each output is in the high-impedance state when the associated output-enable (\overline{OE}) input is high.

Active bus-hold circuitry is provided to hold unused or floating data inputs at a valid logic level.

To ensure the high-impedance state during power up or power down, \overline{OE} should be tied to V_{CC} through a pullup resistor; the minimum value of the resistor is determined by the current-sinking capability of the driver.

The SN74LVT125 is available in TI's shrink small-outline package (DB), which provides the same I/O pin count and functionality of standard small-outline packages in less than half the printed-circuit-board area.

The SN54LVT125 is characterized for operation over the full military temperature range of -55°C to 125°C. The SN74LVT125 is characterized for operation from -40°C to 85°C.

TECHNICAL DOCUMENTS

[▲Back to Top](#)

To view the following documents, [Acrobat Reader 4.0](#) is required.

To download a document to your hard drive, right-click on the link and choose 'Save'.

DATASHEET

[▲Back to Top](#)

Full datasheet in Acrobat PDF: [sn74lvt125.pdf](#) (116 KB,Rev.D) (Updated: 07/01/1995)

APPLICATION NOTES

[▲Back to Top](#)

View Application Notes for [Digital Logic](#)

- [16-Bit Widebus Logic Families in 56-Ball, 0.65-mm Pitch Very Thin Fine-Pitch BGA \(Rev. B\)](#) (SZZA029B - Updated: 05/22/2002)
- [Bus-Interface Devices With Output-Damping Resistors Or Reduced-Drive Outputs \(Rev. A\)](#) (SCBA012A - Updated: 08/01/1997)
- [Evaluation of Nickel/Palladium/Gold-Finished Surface-Mount Integrated Circuits](#) (SZZA026 - Updated: 06/20/2001)
- [Implications of Slow or Floating CMOS Inputs \(Rev. C\)](#) (SCBA004C - Updated: 02/01/1998)
- [Input and Output Characteristics of Digital Integrated Circuits](#) (SDYA010 - Updated: 10/01/1996)
- [LVT Family Characteristics \(Rev. A\)](#) (SCEA002A - Updated: 03/01/1998)
- [LVT-to-LVTH Conversion](#) (SCEA010 - Updated: 12/08/1998)
- [Live Insertion](#) (SDYA012 - Updated: 10/01/1996)
- [Low Voltage Logic Families \(Rev. A\)](#) (SCVAE01A - Updated: 06/01/1998)
- [Power-Up 3-State \(PU3S\) Circuits in TI Standard Logic Devices](#) (SZZA033 - Updated: 05/10/2002)
- [Quad Flatpack No-Lead Logic Packages \(Rev. A\)](#) (SCBA017A - Updated: 09/10/2002)
- [Timing Differences of 10-pF Versus 5OpF Loading](#) (SCEA004 - Updated: 11/01/1996)
- [Understanding Advanced Bus-Interface Products Design Guide](#) (SCAA029, 253 KB - Updated: 05/01/1996)

RELATED DOCUMENTS

[▲Back to Top](#)

View Related Documentation for [Digital Logic](#)

- [Advanced Bus Interface Logic Selection Guide](#) (SCYT126, 453 KB - Updated: 01/09/2001)
- [Logic Reference Guide](#) (SCYB004, 1032 KB - Updated: 10/23/2001)
- [Logic Selection Guide Second Half 2002 \(Rev. R\)](#) (SDYU001R, 4274 KB - Updated: 07/19/2002)
- [Military Low Voltage Solutions](#) (SGYN139, 103 KB - Updated: 04/04/2001)
- [Military Semiconductors Selection Guide 2002 \(Rev. B\)](#) (SGYC003B, 1648 KB - Updated: 04/22/2002)

SAMPLES

[▲Back to Top](#)

ORDERABLE DEVICE	PACKAGE INDUSTRY (TI)	PINS	TEMP (°C)	STATUS	PRODUCT CONTENT	SAMPLES
SN74LVT125D	SOP (D)	14	-40 TO 85	ACTIVE	View Product Content	Request Samples
SN74LVT125NSR	SOP (NS)	14		ACTIVE	View Product Content	Request Samples
SN74LVT125PWR	TSSOP (PW)	14	-40 TO 85	ACTIVE	View Product Content	Request Samples

PRICING/AVAILABILITY/PKG

[▲Back to Top](#)

