

Hex inverting Schmitt-trigger with 5V tolerant input

74LVC14A

FEATURES

- Wide supply voltage range of: 1.2 V to 3.6 V
- In accordance with JEDEC standard no. 8-1A
- Inputs accept voltages up to 5.5 V
- CMOS low power consumption
- Direct interface with TTL levels

APPLICATIONS

- Wave and pulse shapers for highly noisy environments
- Astable multivibrators
- Monostable multivibrators

QUICK REFERENCE DATA

GND = 0 V; $T_{amb} = 25^{\circ}\text{C}$; $t_r \leq t_f \leq 2.5 \text{ ns}$

SYMBOL	PARAMETER	CONDITIONS	TYPICAL	UNIT
t_{PHL}/t_{PLH}	Propagation delay nA to nY	$C_L = 50 \text{ pF}$; $V_{CC} = 3.3 \text{ V}$	4	ns
C_I	Input capacitance		3.5	pF
C_{PD}	Power dissipation capacitance per gate	Notes 1 and 2	25	pF

NOTES:

- C_{PD} is used to determine the dynamic power dissipation (P_D in μW)
 $P_D = C_{PD} \times V_{CC}^2 \times f_i + \sum (C_L \times V_{CC}^2 \times f_o)$ where:
 f_i = input frequency in MHz; C_L = output load capacity in pF;
 f_o = output frequency in MHz; V_{CC} = supply voltage in V;
 $\sum (C_L \times V_{CC}^2 \times f_o)$ = sum of the outputs.
- The condition is $V_I = \text{GND to } V_{CC}$.

ORDERING INFORMATION

PACKAGES	TEMPERATURE RANGE	OUTSIDE NORTH AMERICA	NORTH AMERICA	DWG NUMBER
14-Pin Plastic SO	$-40^{\circ}\text{C to } +85^{\circ}\text{C}$	74LVC14A D	74LVC14A D	SOT108-1
14-Pin Plastic SSOP Type II	$-40^{\circ}\text{C to } +85^{\circ}\text{C}$	74LVC14A DB	74LVC14A DB	SOT337-1
14-Pin Plastic TSSOP Type I	$-40^{\circ}\text{C to } +85^{\circ}\text{C}$	74LVC14A PW	74LVC14APW DH	SOT402-1

PIN CONFIGURATION

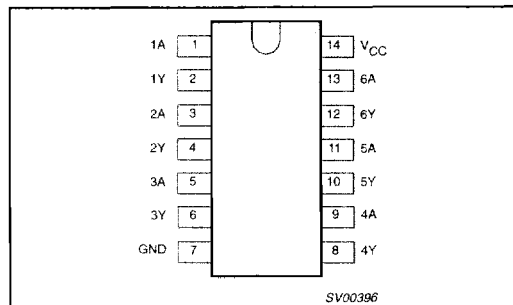

PIN DESCRIPTION

PIN NUMBER	SYMBOL	NAME AND FUNCTION
1, 3, 5, 9, 11, 13	1A – 6A	Data inputs
2, 4, 6, 8, 10, 12	1Y – 6Y	Data outputs
7	GND	Ground (0 V)
14	V_{CC}	Positive supply voltage

Hex inverting Schmitt-trigger with 5V tolerant input

74LVC14A

LOGIC SYMBOL (IEEE/IEC)

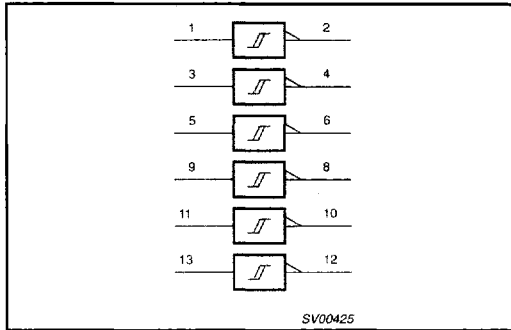

LOGIC SYMBOL

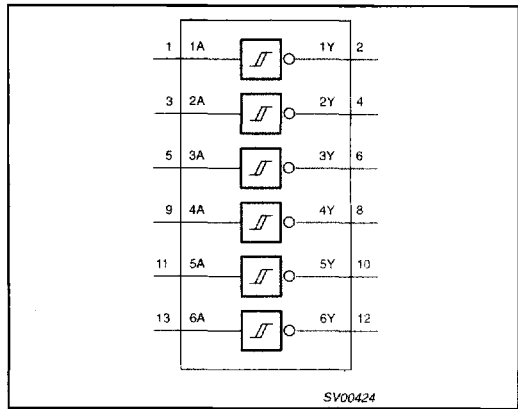

LOGIC DIAGRAM (ONE SCHMITT-TRIGGER)

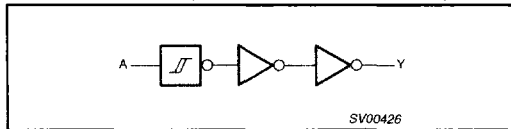

FUNCTION TABLE

INPUT	OUTPUT
nA	nY
L	H
H	L

NOTES:

H = HIGH voltage level
L = LOW voltage level

RECOMMENDED OPERATING CONDITIONS

SYMBOL	PARAMETER	CONDITIONS	LIMITS		UNIT
			MIN	MAX	
V_{CC}	DC supply voltage (for max. speed performance)		2.7	3.6	V
	DC supply voltage (for low-voltage applications)		1.2	3.6	
V_I	DC input voltage range		0	5.5	V
$V_{I/O}$	DC output voltage range; output HIGH or LOW state		0	V_{CC}	V
	DC input voltage range; output 3-State		0	5.5	
T_{amb}	Operating free-air temperature range		-40	+85	°C
t_r, t_f	Input rise and fall times	$V_{CC} = 1.2$ to $2.7V$	0	20	ns/V
		$V_{CC} = 2.7$ to $3.6V$	0	10	

Hex inverting Schmitt-trigger with 5V tolerant input

74LVC14A

ABSOLUTE MAXIMUM RATINGS¹

In accordance with the Absolute Maximum Rating System (IEC 134).
 Voltages are referenced to GND (ground = 0V).

SYMBOL	PARAMETER	CONDITIONS	RATING	UNIT
V_{CC}	DC supply voltage		-0.5 to +6.5	V
I_{IK}	DC input diode current	$V_I < 0$	-50	mA
V_I	DC input voltage	Note 2	-0.5 to +6.5	V
I_{OK}	DC output diode current	$V_O > V_{CC}$ or $V_O < 0$	±50	mA
$V_{I/O}$	DC output voltage; output HIGH or LOW	Note 2	-0.5 to $V_{CC} + 0.5$	V
	DC input voltage; output 3-State	Note 2	-0.5 to 6.5	
I_O	DC output source or sink current	$V_O = 0$ to V_{CC}	±50	mA
I_{GND}, I_{CC}	DC V_{CC} or GND current		±100	mA
T_{stg}	Storage temperature range		-65 to +150	°C
P_{TOT}	Power dissipation per package			
	- plastic mini-pack (SO)	above +70°C derate linearly with 8 mW/K	500	mW
- plastic shrink mini-pack (SSOP and TSSOP)	above +60°C derate linearly with 5.5 mW/K	500		

NOTES:

- Stresses beyond those listed may cause permanent damage to the device. These are stress ratings only and functional operation of the device at these or any other conditions beyond those indicated under "recommended operating conditions" is not implied. Exposure to absolute-maximum-rated conditions for extended periods may affect device reliability.
- The input and output voltage ratings may be exceeded if the input and output current ratings are observed.

DC ELECTRICAL CHARACTERISTICS

Over recommended operating conditions. Voltages are referenced to GND (ground = 0V).

SYMBOL	PARAMETER	TEST CONDITIONS	LIMITS			UNIT
			Temp = -40°C to +85°C			
			MIN	TYP ¹	MAX	
V_{IH}	HIGH level input voltage	$V_{CC} = 1.2V$	V_{CC}			V
		$V_{CC} = 2.7$ to $3.6V$	2.0			
V_{IL}	LOW level input voltage	$V_{CC} = 1.2V$			GND	V
		$V_{CC} = 2.7$ to $3.6V$			0.8	
V_{OH}	HIGH level output voltage	$V_{CC} = 2.7V; V_I = V_{IH}$ or $V_{IL}; I_O = -12mA$	$V_{CC} - 0.5$			V
		$V_{CC} = 3.0V; V_I = V_{IH}$ or $V_{IL}; I_O = -100\mu A$	$V_{CC} - 0.2$	V_{CC}		
		$V_{CC} = 3.0V; V_I = V_{IH}$ or $V_{IL}; I_O = -18mA$	$V_{CC} - 0.6$			
		$V_{CC} = 3.0V; V_I = V_{IH}$ or $V_{IL}; I_O = -24mA$	$V_{CC} - 0.8$			
V_{OL}	LOW level output voltage	$V_{CC} = 2.7V; V_I = V_{IH}$ or $V_{IL}; I_O = 12mA$			0.40	V
		$V_{CC} = 3.0V; V_I = V_{IH}$ or $V_{IL}; I_O = 100\mu A$		GND	0.20	
		$V_{CC} = 3.0V; V_I = V_{IH}$ or $V_{IL}; I_O = 24mA$			0.55	
I_I	Input leakage current	$V_{CC} = 3.6V; V_I = 5.5V$ or GND		±0.1	±5	μA
I_{CC}	Quiescent supply current	$V_{CC} = 3.6V; V_I = V_{CC}$ or GND; $I_O = 0$		0.1	10	μA
ΔI_{CC}	Additional quiescent supply current per input pin	$V_{CC} = 2.3V$ to $3.6V; V_I = V_{CC} - 0.6V; I_O = 0$		5	500	μA

NOTE:

- All typical values are at $V_{CC} = 3.3V$ and $T_{amb} = 25^\circ C$.

Hex inverting Schmitt-trigger with 5V tolerant input

74LVC14A

TRANSFER CHARACTERISTICS

Voltages are referenced to GND (ground = 0 V).

SYMBOL	PARAMETER	T _{amb} (°C)			UNIT	TEST CONDITIONS	
		-40 TO +85				V _{CC} (V)	WAVEFORMS
		MIN	TYP ¹	MAX			
V _{T+}	Positive-going threshold	—	—	1.2	V	1.2	Figures 1 and 2
		1.1	—	2.0		2.7	
		1.1	—	2.0		2.7 to 3.6	
V _{T-}	Negative-going threshold	0	—	—	V	1.2	Figures 1 and 2
		0.8	—	1.5		2.7	
		0.8	—	1.5		2.7 to 3.6	
V _H	Hysteresis (V _{T+} - V _{T-})	—	—	—	V	1.2	Figures 1, 2 and 3
		0.3	0.4	—		2.7	
		0.3	0.45*	—		2.7 to 3.6	

NOTES:

1. All typical values are measured at T_{amb} = 25°C
2. The V_{IH} and V_{IL} from the DC family characteristics are superseded by the V_{T+} and V_{T-}.

TRANSFER CHARACTERISTIC WAVEFORMS

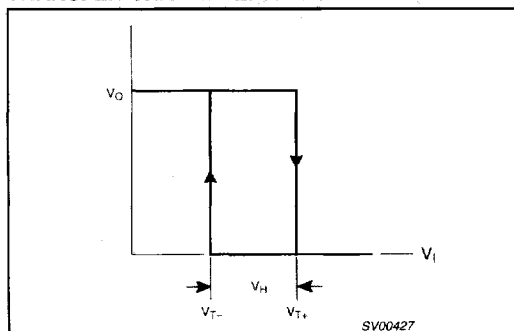

Figure 1. Transfer characteristic.

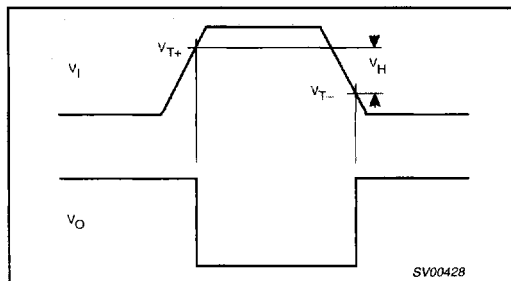

Figure 2. Definition of V_{T+}, V_{T-} and V_H; where V_{T+} and V_{T-} are between limits of 20% and 70%

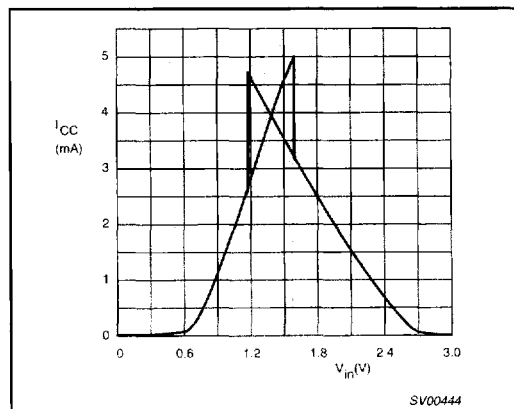

Figure 3. Typical 74LVC14 transfer characteristics; V_{CC} = 3.3 V.

Hex inverting Schmitt-trigger with 5V tolerant input

74LVC14A

AC CHARACTERISTICS

GND = 0 V; $t_r = t_f \leq 2.5$ ns; $C_L = 50$ pF; $R_L = 500\Omega$; $T_{amb} = -40^\circ\text{C}$ to $+85^\circ\text{C}$

SYMBOL	PARAMETER	WAVEFORM	LIMITS						UNIT	
			$V_{CC} = 3.3V \pm 0.3V$			$V_{CC} = 2.7V$				$V_{CC} = 1.2V$
			MIN	TYP ¹	MAX	MIN	TYP	MAX		TYP
t_{PHL}/t_{PLH}	Propagation delay nA to nY	Figure 1, 2	1.5	4.5	6.4	1.5	5.0	7.5	18	ns

NOTE:

1. These typical values are at $V_{CC} = 3.3V$ and $T_{amb} = 25^\circ\text{C}$.

AC WAVEFORMS

$V_M = 1.5$ V at $V_{CC} \geq 2.7$ V

$V_M = 0.5 \cdot V_{CC}$ at $V_{CC} < 2.7$ V

V_{OL} and V_{OH} are the typical output voltage drop that occur with the output load.

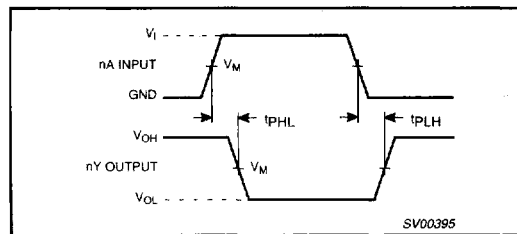

Figure 1. Input (nA) to output (nY) propagation delays.

TEST CIRCUIT

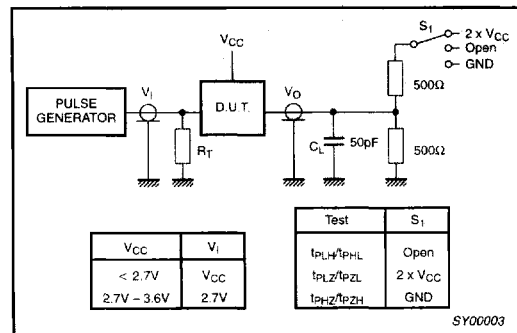

Figure 2. Load circuitry for switching times.

APPLICATION INFORMATION

All values given are typical unless otherwise specified.

Note to Figure 7: $f = \frac{1}{T} \approx \frac{1}{0.8 \times RC}$

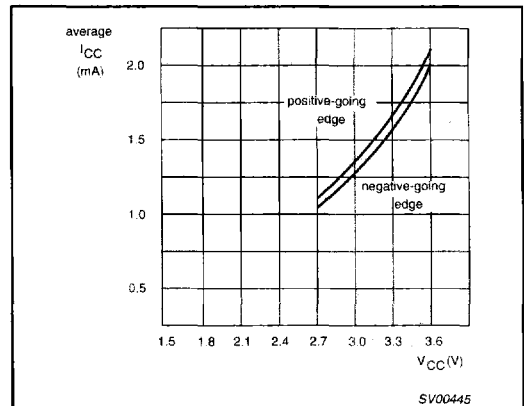

Figure 3. Average I_{CC} for LVC Schmitt-trigger devices; linear change of V_I between 0.8 V to 2.0 V.

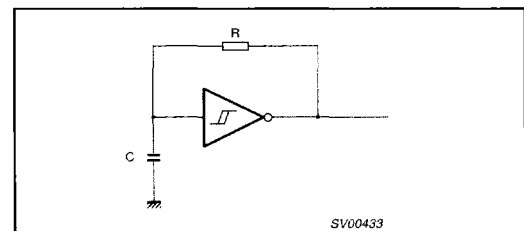

Figure 4. Relaxation oscillator using the LVC14.