

NOTICE OF REVISION (NOR)		1. DATE (YYMMDD) 96-10-17	Form Approved OMB No. 0704-0188
THIS REVISION DESCRIBED BELOW HAS BEEN AUTHORIZED FOR THE DOCUMENT LISTED.			
Public reporting burden for this collection is estimated to average 2 hours per response, including the time for reviewing instructions, searching existing data sources, gathering and maintaining the data needed, and completing and reviewing the collection of information. Send comments regarding this burden estimate or any other aspect of this collection of information, including suggestions for reducing this burden, to Department of Defense, Washington Headquarters Services, Directorate for Information Operations and Reports, 1215 Jefferson Davis Highway, Suite 1204, Arlington, VA 22202-4302, and to the Office of Management and Budget, Paperwork Reduction Project (0704-0188), Washington, DC 20503.			
PLEASE DO NOT RETURN YOUR COMPLETED FORM TO EITHER OF THESE ADDRESSES. RETURN COMPLETED FORM TO THE GOVERNMENT ISSUING CONTRACTING OFFICER FOR THE CONTRACT/PROCURING ACTIVITY NUMBER LISTED IN ITEM 2 OF THIS FORM.			
4. ORIGINATOR	b. ADDRESS (Street, City, State, Zip Code) Defense Supply Center, Columbus 3990 E. Broad Street Columbus, OH 43216-5000	5. CAGE CODE 67268	6. NOR NO. 5962-R025-97
a. TYPED NAME (First, Middle Initial, Last)		7. CAGE CODE 67268	8. DOCUMENT NO. 5962-92259
9. TITLE OF DOCUMENT MICROCIRCUIT, DIGITAL, FAST CMOS, 16-BIT NONINVERTING TRANSPARENT LATCH WITH THREE-STATE OUTPUTS, TTL COMPATIBLE INPUTS AND LIMITED OUTPUT VOLTAGE SWING, MONOLITHIC SILICON		10. REVISION LETTER	
		a. CURRENT Initial	b. NEW A
		11. ECP NO. N/A	
12. CONFIGURATION ITEM (OR SYSTEM) TO WHICH ECP APPLIES All			
13. DESCRIPTION OF REVISION			
<p>Sheet 1: Revisions ltr column; add "A". Revisions description column; add "Changes in accordance with NOR 5962-R025-97". Revisions date column; add "96-10-17". Revision level block; add "A". Rev status of sheets; for sheets 1 and 6, add "A".</p> <p>Sheet 6: Table I, output short circuit current, I_{OS}; change maximum limit from "-225 mA" to "-250 mA". Revision level block; add "A".</p>			
14. THIS SECTION FOR GOVERNMENT USE ONLY			
a. (X one)	X	(1) Existing document supplemented by the NOR may be used in manufacture.	
		(2) Revised document must be received before manufacturer may incorporate this change.	
		(3) Custodian of master document shall make above revision and furnish revised document.	
b. ACTIVITY AUTHORIZED TO APPROVE CHANGE FOR GOVERNMENT DSCC-VAC		c. TYPED NAME (First, Middle Initial, Last) Monica L. Poelking	
d. TITLE Chief, Custom Microelectronics Team	e. SIGNATURE Monica L. Poelking		f. DATE SIGNED (YYMMDD) 96-10-17
15a. ACTIVITY ACCOMPLISHING REVISION DSCC-VAC	b. REVISION COMPLETED (Signature) Thanh V. Nguyen		c. DATE SIGNED (YYMMDD) 96-10-17

REVISIONS

LTR	DESCRIPTION										DATE (YR-MO-DA)	APPROVED

REV																				
SHEET																				
REV																				
SHEET	15	16	17	18	19	20														

REV STATUS OF SHEETS	REV																			
	SHEET	1	2	3	4	5	6	7	8	9	10	11	12	13	14					

<p align="center">STANDARD MICROCIRCUIT DRAWING</p> <p>THIS DRAWING IS AVAILABLE FOR USE BY ALL DEPARTMENTS AND AGENCIES OF THE DEPARTMENT OF DEFENSE</p> <p>AMSC N/A</p>	PREPARED BY Thanh V. Nguyen	DEFENSE ELECTRONICS SUPPLY CENTER DAYTON, OHIO 45444	
	CHECKED BY Thanh V. Nguyen	MICROCIRCUIT, DIGITAL, FAST CMOS, 16-BIT NONINVERTING TRANSPARENT LATCH WITH THREE-STATE OUTPUTS, TTL COMPATIBLE INPUTS AND LIMITED OUTPUT VOLTAGE SWING, MONOLITHIC SILICON	
	APPROVED BY Monica L. Poelking		
	DRAWING APPROVAL DATE 94-09-22		
	REVISION LEVEL	SIZE A	CAGE CODE 67268
	SHEET 1	OF	20

1. SCOPE

1.1 Scope. This drawing forms a part of a one part - one part number documentation system (see 6.6 herein). Two product assurance classes consisting of military high reliability (device classes Q and M) and space application (device class V), and a choice of case outlines and lead finishes are available and are reflected in the Part or Identifying Number (PIN). Device class M microcircuits represent non-JAN class B microcircuits in accordance with 1.2.1 of MIL-STD-883, "Provisions for the use of MIL-STD-883 in conjunction with compliant non-JAN devices". When available, a choice of Radiation Hardness Assurance (RHA) levels are reflected in the PIN.

1.2 PIN. The PIN shall be as shown in the following example:

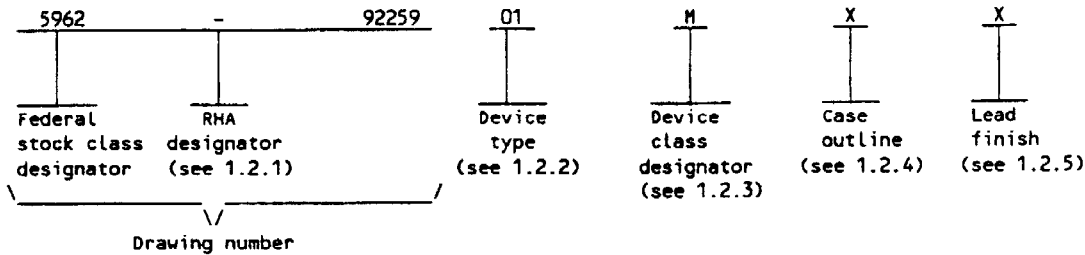

1.2.1 RHA designator. Device class M RHA marked devices shall meet the MIL-I-38535 appendix A specified RHA levels and shall be marked with the appropriate RHA designator. Device classes Q and V RHA marked devices shall meet the MIL-I-38535 specified RHA levels and shall be marked with the appropriate RHA designator. A dash (-) indicates a non-RHA device.

1.2.2 Device type(s). The device type(s) shall identify the circuit function as follows:

<u>Device type</u>	<u>Generic number</u>	<u>Circuit function</u>
01	54FCT16373T	16-bit noninverting transparent latch with three-state outputs, TTL compatible inputs and limited output voltage swing
02	54FCT16373AT	16-bit noninverting transparent latch with three-state outputs, TTL compatible inputs and limited output voltage swing
03	54FCT16373CT	16-bit noninverting transparent latch with three-state outputs, TTL compatible inputs and limited output voltage swing

1.2.3 Device class designator. The device class designator shall be a single letter identifying the product assurance level as follows:

<u>Device class</u>	<u>Device requirements documentation</u>
M	Vendor self-certification to the requirements for non-JAN class B microcircuits in accordance with 1.2.1 of MIL-STD-883
Q or V	Certification and qualification to MIL-I-38535

1.2.4 Case outline(s). The case outline(s) shall be as designated in MIL-STD-1835, and as follows:

<u>Outline letter</u>	<u>Descriptive designator</u>	<u>Terminals</u>	<u>Package style</u>
X	GDFP1-F48	48	Flat pack

1.2.5 Lead finish. The lead finish shall be as specified in MIL-STD-883 (see 3.1 herein) for class M or MIL-I-38535 for classes Q and V. Finish letter "X" shall not be marked on the microcircuit or its packaging. The "X" designation is for use in specifications when lead finishes A, B, and C are considered acceptable and interchangeable without preference.

STANDARD MICROCIRCUIT DRAWING DEFENSE ELECTRONICS SUPPLY CENTER DAYTON, OHIO 45444	SIZE A		5962-92259
		REVISION LEVEL	SHEET 2

1.3 Absolute maximum ratings. 1/ 2/ 3/

Supply voltage range (V_{CC})	- - - - -	-0.5 V dc to +7.0 V dc
DC input voltage range (V_{IN})	- - - - -	-0.5 V dc to V_{CC} + 0.5 V dc 4/
DC output voltage range (V_{OUT})	- - - - -	-0.5 V dc to V_{CC}
DC input clamp current (I_{IK}) ($V_{IN} = -0.5$ V)	- - - - -	-20 mA
DC output clamp current (I_{OK}) ($V_{OUT} = -0.5$ V and +7.0 V)	- - - - -	± 20 mA
DC output source current (I_{OH}) (per output)	- - - - -	-30 mA
DC output sink current (I_{OL}) (per output)	- - - - -	+70 mA
DC V_{CC} current (I_{CC})	- - - - -	± 480 mA
Ground current (I_{GND})	- - - - -	+1120 mA
Storage temperature range (T_{STG})	- - - - -	-65°C to +150°C
Case temperature under bias (T_{BIAS})	- - - - -	-65°C to +135°C
Lead temperature (soldering, 10 seconds)	- - - - -	+300°C
Thermal resistance, junction-to-case (Θ_{JC})	- - - - -	See MIL-STD-1835
Junction temperature (T_J)	- - - - -	+175°C
Maximum power dissipation (P_D)	- - - - -	1.0 W

1.4 Recommended operating conditions. 2/ 3/

Supply voltage range (V_{CC})	- - - - -	+4.5 V dc to +5.5 V dc
Input voltage range (V_{IN})	- - - - -	+0.0 V dc to V_{CC}
Output voltage range (V_{OUT})	- - - - -	+0.0 V dc to V_{CC}
Maximum low level input voltage (V_{IL})	- - - - -	0.8 V
Minimum high level input voltage (V_{IH})	- - - - -	2.0 V
Case operating temperature range (T_C)	- - - - -	-55°C to +125°C
Maximum input rise or fall rate ($\Delta t/\Delta V$):		
(from $V_{IN} = 0.3$ V to 2.7 V, 2.7 V to 0.3 V)	- - - - -	2.5 ns/V
Maximum high level output current (I_{OH})	- - - - -	-24 mA
Maximum low level output current (I_{OL})	- - - - -	48 mA

1.5 Digital logic testing for device classes Q and V.

Fault coverage measurement of manufacturing logic tests (MIL-STD-883, test method 5012) - - - - - XX percent 5/

2. APPLICABLE DOCUMENTS

2.1 Government specification, standards, bulletin, and handbook. Unless otherwise specified, the following specification, standards, bulletin, and handbook of the issue listed in that issue of the Department of Defense Index of Specifications and Standards specified in the solicitation, form a part of this drawing to the extent specified herein.

- 1/ Stresses above the absolute maximum rating may cause permanent damage to the device. Extended operation at the maximum levels may degrade performance and affect reliability.
- 2/ Unless otherwise noted, all voltages are referenced to GND.
- 3/ The limits for the parameters specified herein shall apply over the full specified V_{CC} range and case temperature range of -55°C to +125°C.
- 4/ For $V_{CC} \geq 6.5$ V, the upper limit on the range is limited to 7.0 V.
- 5/ Values will be added when they become available.

STANDARD MICROCIRCUIT DRAWING DEFENSE ELECTRONICS SUPPLY CENTER DAYTON, OHIO 45444	SIZE A		5962-92259
		REVISION LEVEL	SHEET 3

SPECIFICATION

MILITARY

MIL-I-38535 - Integrated Circuits, Manufacturing, General Specification for.

STANDARDS

MILITARY

MIL-STD-883 - Test Methods and Procedures for Microelectronics.
MIL-STD-973 - Configuration Management.
MIL-STD-1835 - Microcircuit Case Outlines

BULLETIN

MILITARY

MIL-BUL-103 - List of Standardized Military Drawings (SMD's).

HANDBOOK

MILITARY

MIL-HDBK-780 - Standardized Military Drawings.

(Copies of the specification, standards, bulletin, and handbook required by manufacturers in connection with specific acquisition functions should be obtained from the contracting activity or as directed by the contracting activity.)

2.2 Order of precedence. In the event of a conflict between the text of this drawing and the references cited herein, the text of this drawing shall take precedence.

3. REQUIREMENTS

3.1 Item requirements. The individual item requirements for device class M shall be in accordance with 1.2.1 of MIL-STD-883, "Provisions for the use of MIL-STD-883 in conjunction with compliant non-JAN devices" and as specified herein. The individual item requirements for device classes Q and V shall be in accordance with MIL-I-38535, the device manufacturer's Quality Management (QM) plan, and as specified herein.

3.2 Design, construction, and physical dimensions. The design, construction, and physical dimensions shall be as specified in MIL-STD-883 (see 3.1 herein) for device class M and MIL-I-38535 for device classes Q and V and herein.

3.2.1 Case outline. The case outline shall be in accordance with 1.2.4 herein.

3.2.2 Terminal connections. The terminal connections shall be as specified on figure 1.

3.2.3 Truth table. The truth table shall be as specified on figure 2.

3.2.4 Logic diagram. The logic diagram shall be as specified on figure 3.

3.2.5 Ground bounce load circuit and waveforms. The ground bounce load circuit and waveforms shall be as specified on figure 4.

3.2.6 Switching waveforms and test circuit. The switching waveforms and test circuit shall be as specified on figure 5.

3.3 Electrical performance characteristics and postirradiation parameter limits. Unless otherwise specified herein, the electrical performance characteristics and postirradiation parameter limits are as specified in table I and shall apply over the full case operating temperature range. Test conditions for these specified characteristics and limits are as specified in table I.

3.4 Electrical test requirements. The electrical test requirements shall be the subgroups specified in table II. The electrical tests for each subgroup are defined in table I.

Table with 4 columns: STANDARD MICROCIRCUIT DRAWING DEFENSE ELECTRONICS SUPPLY CENTER DAYTON, OHIO 45444; SIZE A; REVISION LEVEL; 5962-92259 SHEET 4

3.5 Marking. The part shall be marked with the PIN listed in 1.2 herein. Marking for device class M shall be in accordance with MIL-STD-883 (see 3.1 herein). In addition, the manufacturer's PIN may also be marked as listed in MIL-BUL-103. Marking for device classes Q and V shall be in accordance with MIL-I-38535.

3.5.1 Certification/compliance mark. The compliance mark for device class M shall be a "C" as required in MIL-STD-883 (see 3.1 herein). The certification mark for device classes Q and V shall be a "QML" or "Q" as required in MIL-I-38535.

3.6 Certificate of compliance. For device class M, a certificate of compliance shall be required from a manufacturer in order to be listed as an approved source of supply in MIL-BUL-103 (see 6.7.2 herein). For device classes Q and V, a certificate of compliance shall be required from a QML-38535 listed manufacturer in order to supply to the requirements of this drawing (see 6.7.1 herein). The certificate of compliance submitted to DESC-EC prior to listing as an approved source of supply for this drawing shall affirm that the manufacturer's product meets, for device class M the requirements of MIL-STD-883 (see 3.1 herein), or for device classes Q and V, the requirements of MIL-I-38535 and the requirements herein.

3.7 Certificate of conformance. A certificate of conformance as required for device class M in MIL-STD-883 (see 3.1 herein) or for device classes Q and V in MIL-I-38535 shall be provided with each lot of microcircuits delivered to this drawing.

3.8 Notification of change for device class M. For device class M, notification to DESC-EC of change of product (see 6.2 herein) involving devices acquired to this drawing is required for any change as defined in MIL-STD-973.

3.9 Verification and review for device class M. For device class M, DESC, DESC's agent, and the acquiring activity retain the option to review the manufacturer's facility and applicable required documentation. Offshore documentation shall be made available onshore at the option of the reviewer.

3.10 Microcircuit group assignment for device class M. Device class M devices covered by this drawing shall be in microcircuit group number 38 (see MIL-I-38535, appendix A).

4. QUALITY ASSURANCE PROVISIONS

4.1 Sampling and inspection. For device class M, sampling and inspection procedures shall be in accordance with MIL-STD-883 (see 3.1 herein). For device classes Q and V, sampling and inspection procedures shall be in accordance with MIL-I-38535 and the device manufacturer's QM plan.

4.2 Screening. For device class M, screening shall be in accordance with method 5004 of MIL-STD-883, and shall be conducted on all devices prior to quality conformance inspection. For device classes Q and V, screening shall be in accordance with MIL-I-38535, and shall be conducted on all devices prior to qualification and technology conformance inspection.

4.2.1 Additional criteria for device class M.

a. Burn-in test, method 1015 of MIL-STD-883.

(1) Test condition A, B, C or D. The test circuit shall be maintained by the manufacturer under document revision level control and shall be made available to the preparing or acquiring activity upon request. The test circuit shall specify the inputs, outputs, biases, and power dissipation, as applicable, in accordance with the intent specified in test method 1015.

(2) $T_A = +125^{\circ}\text{C}$, minimum.

b. Interim and final electrical test parameters shall be as specified in table II herein.

STANDARD MICROCIRCUIT DRAWING DEFENSE ELECTRONICS SUPPLY CENTER DAYTON, OHIO 45444	SIZE A		5962-92259
		REVISION LEVEL	SHEET 5

TABLE I. Electrical performance characteristics.

Test and MIL-STD-883 test method 1/	Symbol	Test conditions 2/ -55°C ≤ T _c ≤ +125°C +4.5 V ≤ V _{CC} ≤ +5.5 V unless otherwise specified		Device type	V _{CC}	Group A subgroups	Limits 3/		Unit
							Min	Max	
High level output voltage 3006	V _{OH1} 4/	For all inputs affecting output under test V _{IN} = 2.0 V or 0.8 V	I _{OH} = -300 μA	ALL	4.5 V	1, 2, 3	3.0	V _{CC} -0.5	V
	V _{OH2}		I _{OH} = -3 mA				2.5		
	V _{OH3}	For all other inputs V _{IN} = V _{CC} or GND	I _{OH} = -12 mA				2.4		
	V _{OH4}		I _{OH} = -24 mA				2.0		
Low level output voltage 3007	V _{OL1} 4/		I _{OL} = 300 μA	ALL	4.5 V	1, 2, 3		0.2	V
	V _{OL2}		I _{OL} = 48 mA					0.55	
Negative input clamp voltage 3022	V _{IC-}	For input under test, I _{IN} = -18 mA		ALL	4.5 V	1, 2, 3		-1.2	V
Three-state output leakage current high 3021	I _{OZH} 5/ 6/	mOE = 2.0 V or 0.8 V For all other inputs V _{IN} = V _{CC} or GND	V _{OUT} = V _{CC}	ALL	5.5 V	1, 2		±1.0	μA
						3		±5.0	
Three-state output leakage current low 3020	I _{OZL} 5/ 6/		V _{OUT} = GND	ALL	5.5 V	1, 2		±1.0	μA
						3		±5.0	
Input current high 3010	I _{IH}	For input under test, V _{IN} = V _{CC} For all other inputs V _{IN} = V _{CC} or GND		ALL	5.5 V	1, 2		±1.0	μA
							3		
Input current low 3009	I _{IL}	For input under test, V _{IN} = GND For all other inputs V _{IN} = V _{CC} or GND		ALL	5.5 V	1, 2		±1.0	μA
							3		
Output short circuit current 3011	I _{OS} 7/	For all inputs, V _{IN} = V _{CC} or GND V _{OUT} = GND		ALL	5.5 V	1, 2, 3	-80	-225	mA
Output drive current 3011	I _O 7/	V _{OUT} = 2.5 V		ALL	5.5 V	1, 2, 3	-50	-180	mA
Off-state leakage current	I _{OFF} 8/	For input or output under test V _{IN} or V _{OUT} = 4.5 V All other pins at 0.0 V		ALL	0.0 V	1, 2		±1.0	μA
							3		
Dynamic power supply current	I _{CCD} 4/ 9/	Outputs open		ALL	5.5 V	4, 5, 6		100	μA/ MHz·Bit
Quiescent supply current delta, TTL input level 3005	ΔI _{CC} 10/	For input under test V _{IN} = 3.4 V For all other inputs V _{IN} = V _{CC} or GND		ALL	5.5 V	1, 2, 3		1.5	mA

See footnotes at end of table.

STANDARD MICROCIRCUIT DRAWING DEFENSE ELECTRONICS SUPPLY CENTER DAYTON, OHIO 45444	SIZE A		5962-92259
		REVISION LEVEL	SHEET 6

TABLE I. Electrical performance characteristics - Continued.

Test and MIL-STD-883 test method 1/	Symbol	Test conditions 2/ -55°C ≤ T _C ≤ +125°C +4.5 V ≤ V _{CC} ≤ +5.5 V unless otherwise specified		Device type	V _{CC}	Group A subgroups	Limits 3/		Unit
							Min	Max	
Quiescent supply current, outputs high 3005	I _{CCH}	mOE = GND For all other inputs V _{IN} = V _{CC} or GND		ALL	5.5 V	1, 2, 3		0.5	mA
Quiescent supply current, outputs low 3005	I _{CCL}			ALL	5.5 V	1, 2, 3		0.5	mA
Quiescent supply current, outputs disabled 3005	I _{CCZ} 5/	mOE = V _{CC} For all other inputs V _{IN} = V _{CC} or GND		ALL	5.5 V	1, 2, 3		0.5	mA
Total supply current	I _{CCT1} 11/	Outputs open mOE = GND, mLE = V _{CC} One bit toggling f _i = 10 MHz 50% duty cycle For nonswitching input, V _{IN} = V _{CC} or GND	For switching inputs V _{IN} = V _{CC} or GND	ALL	5.5 V	4, 5, 6		1.5	mA
			For switching inputs V _{IN} = 3.4 V or GND			4, 5, 6		2.3	
	I _{CCT2} 4/ 11/	Outputs open mOE = GND, mLE = V _{CC} Sixteen bits toggling f _i = 2.5 MHz 50% duty cycle For nonswitching input, V _{IN} = V _{CC} or GND	For switching inputs V _{IN} = V _{CC} or GND	ALL	5.5 V	4, 5, 6		4.5	
			For switching inputs V _{IN} = 3.4 V or GND			4, 5, 6		16.5	
Input capacitance 3012	C _{IN} 12/	T _C = +25°C See 4.4.1b		ALL	GND	4		6.0	pF
Output capacitance 3012	C _{OUT} 12/			ALL	GND	4		8.0	pF
Low level ground bounce noise	V _{OLP} 12/ 13/	V _{IH} = 3.0 V, V _{IL} = 0.0 V T _A = +25°C See figure 4		ALL	5.0 V	4		1650	mV
	V _{OLV} 12/ 13/					4		-1800	
High level V _{CC} bounce noise	V _{OHP} 12/ 13/			ALL	5.0 V	4		750	mV
	V _{OHV} 12/ 13/					4		-650	

See footnotes at end of table.

STANDARD MICROCIRCUIT DRAWING DEFENSE ELECTRONICS SUPPLY CENTER DAYTON, OHIO 45444	SIZE A		5962-92259
		REVISION LEVEL	SHEET 7

TABLE I. Electrical performance characteristics - Continued.

Test and MIL-STD-883 test method <u>1/</u>	Symbol	Test conditions <u>2/</u> -55°C ≤ T _C ≤ +125°C +4.5 V ≤ V _{CC} ≤ +5.5 V unless otherwise specified	Device type	V _{CC}	Group A subgroups	Limits <u>3/</u>		Unit
						Min	Max	
Functional test 3014	<u>14/</u>	V _{IH} = 2.0 V, V _{IL} = 0.8 V Verify output V _O See 4.4.1c	ALL	4.5 V	7, 8	L	H	
				5.5 V	7, 8	L	H	
Propagation delay time, mOn to mOn 3003	t _{PLH1'} t _{PHL1} <u>15/</u>	C _L = 50 pF minimum R _L = 500Ω See figure 5	01	4.5 V	9, 10, 11	1.5	8.5	ns
			02			1.5	5.6	
			03			1.5	5.1	
Propagation delay time, mLE to mOn 3003	t _{PLH2'} t _{PHL2} <u>15/</u>		01	4.5 V	9, 10, 11	2.0	15.0	ns
			02			2.0	9.8	
			03			2.0	8.0	
Propagation delay time, output enable, mOE to mOn 3003	t _{PZH'} t _{PZL} <u>15/</u>		01	4.5 V	9, 10, 11	1.5	13.5	ns
			02			1.5	7.5	
			03			1.5	6.3	
Propagation delay time, output disable, mOE to mOn 3003	t _{PHZ'} t _{PLZ} <u>15/</u>		01	4.5 V	9, 10, 11	1.5	10.0	ns
			02			1.5	6.5	
			03			1.5	5.9	
Output skew 3003	t _{sk(o)} <u>16/</u>		ALL	4.5 V	9, 10, 11		0.5	ns
Setup time, high or low, mOn to mLE	t _S <u>15/</u>		ALL	4.5 V	9, 10, 11	2.0		ns
Hold time, high or low, mOn from mLE	t _H <u>15/</u>		ALL	4.5 V	9, 10, 11	1.5		ns
Latch enable pulse width, high	t _W <u>15/</u>		ALL	4.5 V	9, 10, 11	6.0		ns

1/ For tests not listed in the referenced MIL-STD-883 (e.g. ΔI_{CC}), utilize the general test procedure of 883 under the conditions listed herein.

2/ Each input/output, as applicable, shall be tested at the specified temperature, for the specified limits, to the tests in table I herein. Output terminals not designated shall be high level logic, low level logic, or open, except for all I_{CC} and ΔI_{CC} tests, the output terminals shall be open. When performing these tests, the current meter shall be placed in the circuit such that all current flows through the meter.

STANDARD MICROCIRCUIT DRAWING DEFENSE ELECTRONICS SUPPLY CENTER DAYTON, OHIO 45444	SIZE A		5962-92259
		REVISION LEVEL	SHEET 8

TABLE I. Electrical performance characteristics - Continued.

- 3/ For negative and positive voltage and current values, the sign designates the potential difference in reference to GND and the direction of current flow, respectively; and the absolute value of the magnitude, not the sign, is relative to the minimum and maximum limits, as applicable, listed herein. All devices shall meet or exceed the limits specified in table I at $4.5 \text{ V} \leq V_{CC} \leq 5.5 \text{ V}$.
- 4/ This parameter is guaranteed, if not tested, to the limits specified in table I herein.
- 5/ Three-state output conditions are required.
- 6/ This test may be performed using $V_{IH} = 3.0 \text{ V}$. When $V_{IH} = 3.0 \text{ V}$ is used, the test is guaranteed for $V_{IH} = 2.0 \text{ V}$.
- 7/ Not more than one output should be tested at a time. The duration of the test should not exceed one second.
- 8/ For I_{OFF} testing, test each input and output.
- 9/ I_{CCD} may be verified by the following equation:

$$I_{CCD} = \frac{I_{CCT} - I_{CC} - D_H N_T \Delta I_{CC}}{f_{CP}/2 + f_i N_i}$$

where I_{CCT} , I_{CC} (I_{CCL} or I_{CCH} in table I), and ΔI_{CC} shall be the measured values of these parameters, for the device under test, when tested as described in table I, herein. The values for D_H , N_T , f_{CP} , f_i , and N_i shall be as listed in the test conditions column for I_{CCT} in table I, herein.

- 10/ This test may be performed either one input at a time (preferred method) or with all input pins simultaneously at $V_{IN} = V_{CC} - 2.1 \text{ V}$ (alternate method). Classes Q and V shall use the preferred method. When the test is performed using the alternate test method, the maximum limit is equal to the number of inputs at a high TTL input level times 1.5 mA; and the preferred method and limits are guaranteed.

- 11/ I_{CCT} is calculated as follows:

$$I_{CCT} = I_{CC} + D_H N_T \Delta I_{CC} + I_{CCD}(f_{CP}/2 + f_i N_i)$$

where

I_{CC} = Quiescent supply current (any I_{CCL} or I_{CCH})

D_H = Duty cycle for TTL inputs at 3.4 V

N_T = Number of TTL inputs at 3.4 V

ΔI_{CC} = Quiescent supply current delta, TTL inputs at 3.4 V

I_{CCD} = Dynamic power supply current caused by an input transition pair (HLH or LHL)

f_{CP} = Clock frequency for registered devices ($f_{CP} = 0$ for nonregistered devices)

f_i = Input frequency

N_i = Number of inputs at f_i

- 12/ This test is required only for group A testing; see 4.4.1 herein.

STANDARD MICROCIRCUIT DRAWING DEFENSE ELECTRONICS SUPPLY CENTER DAYTON, OHIO 45444	SIZE A		5962-92259
		REVISION LEVEL	SHEET 9

TABLE I. Electrical performance characteristics - Continued.

13/ This test is for qualification only. Ground and V_{CC} bounce tests are performed on a non-switching (quiescent) output and are used to measure the magnitude of induced noise caused by other simultaneously switching outputs. The test is performed on a low noise bench test fixture. For the device under test, all outputs shall be loaded with 500 Ω of load resistance and a minimum of 50 pF of load capacitance (see figure 4). Only chip capacitors and resistors shall be used. The output load components shall be located as close as possible to the device outputs. It is suggested, that whenever possible, this distance be kept to less than 0.25 inches. Decoupling capacitors shall be placed in parallel from V_{CC} to ground. The values of these decoupling capacitors shall be determined by the device manufacturer. The low and high level ground and V_{CC} bounce noise is measured at the quiet output using a 1 GHz minimum bandwidth oscilloscope with a 50 Ω input impedance.

The device inputs shall be conditioned such that all outputs are at a high nominal V_{OH} level. The device inputs shall then be conditioned such that they switch simultaneously and the output under test remains at V_{OH} as all other outputs possible are switched from V_{OH} to V_{OL} . V_{OHV} and V_{OHP} are then measured from the nominal V_{OH} level to the largest negative and positive peaks, respectively (see figure 4). This is then repeated with the same outputs not under test switching from V_{OL} to V_{OH} .

The device inputs shall be conditioned such that all outputs are at a low nominal V_{OL} level. The device inputs shall then be conditioned such that they switch simultaneously and the output under test remains at V_{OL} as all other outputs possible are switched from V_{OL} to V_{OH} . V_{OLP} and V_{OLV} are then measured from the nominal V_{OL} level to the largest positive and negative peaks, respectively (see figure 4). This is then repeated with the same outputs not under test switching from V_{OH} to V_{OL} .

14/ Tests shall be performed in sequence, attributes data only. Functional tests shall include the truth table and other logic patterns used for fault detection. The test vectors used to verify the truth table shall, at a minimum, test all functions of each input and output. All possible input to output logic patterns per function shall be guaranteed, if not tested, to the truth table in figure 2 herein. Functional tests shall be performed in sequence as approved by the qualifying activity on qualified devices. For outputs, $L < 1.5$ V, $H \geq 1.5$ V.

15/ AC limits at $V_{CC} = 5.5$ V are equal to the limits at $V_{CC} = 4.5$ V and guaranteed by testing at $V_{CC} = 4.5$ V. Minimum propagation delay time limits for $V_{CC} = 4.5$ V and 5.5 V are guaranteed, if not tested, to the limits specified in table I, herein. For propagation delay tests, all paths must be tested.

16/ This parameter is guaranteed, if not tested, to the limits specified in table I herein. The limits at $V_{CC} = 5.5$ V are guaranteed and equal to the limits at $V_{CC} = 4.5$ V. $t_{sk(o)}$ is the absolute value of the difference between the actual propagation delay for any two separate outputs of the same package switching in the same direction (low-to-high, high-to-low).

STANDARD MICROCIRCUIT DRAWING DEFENSE ELECTRONICS SUPPLY CENTER DAYTON, OHIO 45444	SIZE A		5962-92259
		REVISION LEVEL	SHEET 10

Device types		01, 02, 03			
Case outline		X			
Terminal number	Terminal symbol	Terminal number	Terminal symbol	Terminal number	Terminal symbol
1	$\overline{10E}$	17	204	33	203
2	101	18	V_{CC}	34	GND
3	102	19	205	35	202
4	GND	20	206	36	201
5	103	21	GND	37	108
6	104	22	207	38	107
7	V_{CC}	23	$\overline{208}$	39	GND
8	105	24	20E	40	106
9	106	25	2LE	41	105
10	GND	26	208	42	V_{CC}
11	107	27	207	43	104
12	108	28	GND	44	103
13	201	29	206	45	GND
14	202	30	205	46	102
15	GND	31	V_{CC}	47	101
16	203	32	204	48	1LE

Terminal descriptions	
Terminal symbol	Description
mDn ($m = 1$ to 2 , $n = 1$ to 8)	Data inputs
mLE ($m = 1$ to 2)	Latch enable inputs (active high)
\overline{mOE} ($m = 1$ to 2)	Output enable control inputs (active low)
mOn ($m = 1$ to 2 , $n = 1$ to 8)	Three-state outputs

FIGURE 1. Terminal connections.

Device types 01, 02, 03				
Inputs			Internal	Outputs
\overline{mOE}	mLE	mDn	\overline{mOn}	mOn
H	X	X	X	Z
L	H	L	H	L
L	H	H	L	H
L	↓	L	H	L
L	↓	h	L	H
L	L	X	00	00

H = High voltage level
 L = Low voltage level
 ↓ = High-to-low transition
 l = Low voltage level meeting the setup and hold times in table I relative to the transition of LE
 h = High voltage level meeting the setup and hold times in table I relative to the transition of LE
 X = Irrelevant
 Z = High impedance
 00 = Previous 00 before high-to-low transition of latch enable

FIGURE 2. Truth table.

STANDARD MICROCIRCUIT DRAWING DEFENSE ELECTRONICS SUPPLY CENTER DAYTON, OHIO 45444	SIZE A		5962-92259
		REVISION LEVEL	SHEET 11

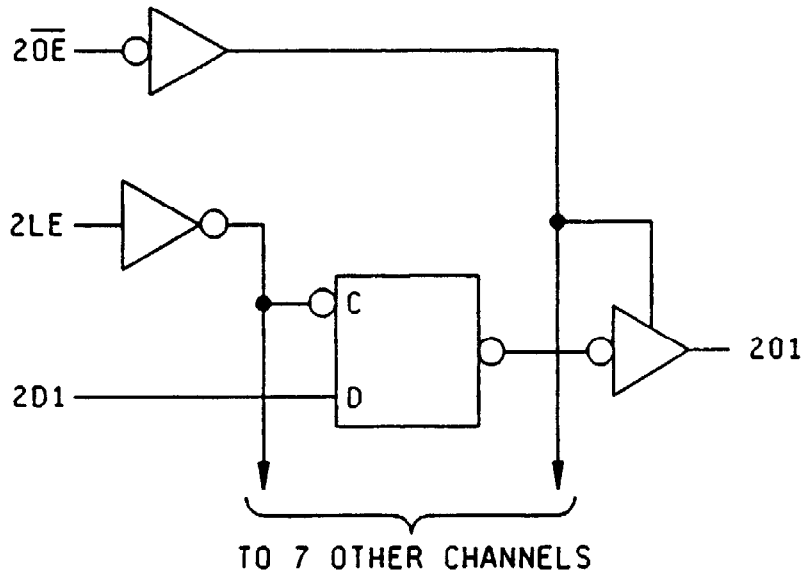
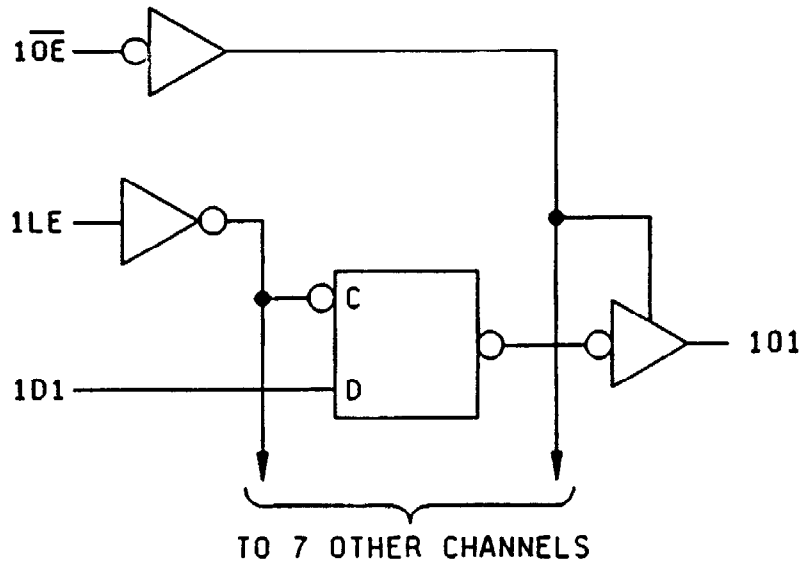

FIGURE 3. Logic diagram.

STANDARD
MICROCIRCUIT DRAWING
DEFENSE ELECTRONICS SUPPLY CENTER
DAYTON, OHIO 45444

SIZE
A

5962-92259

REVISION LEVEL

SHEET
12

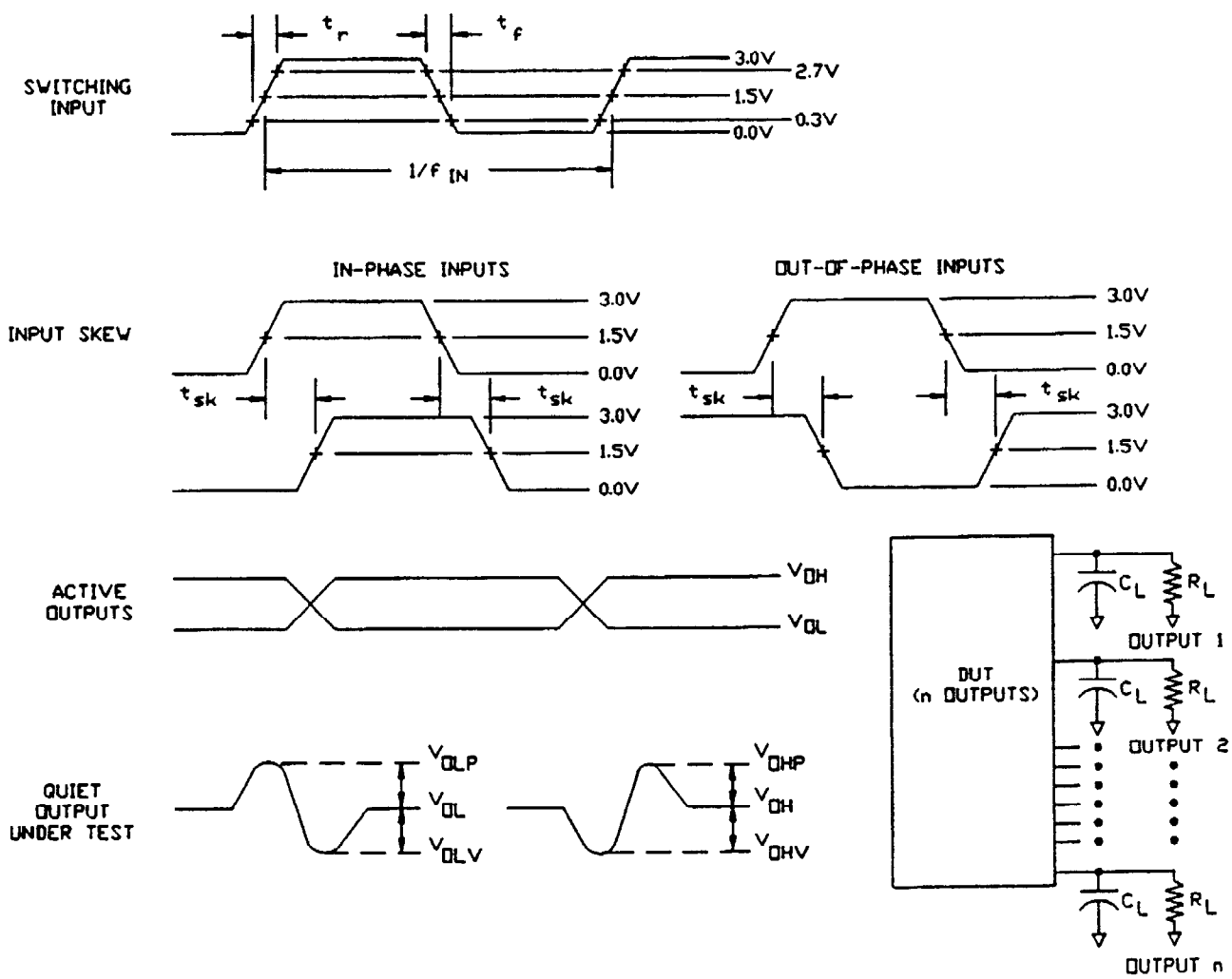

NOTES:

1. C_L includes a 47 pF chip capacitor (-0 percent, +20 percent) and at least 3 pF of equivalent capacitance from the test jig and probe.
2. $R_L = 450\Omega \pm 1$ percent, chip resistor in series with a 50 Ω termination. For monitored outputs, the 50 Ω termination shall be the 50 Ω characteristic impedance of the coaxial connector to the oscilloscope.
3. Input signal to the device under test:
 - a. $V_{IN} = 0.0$ V to 3.0 V; duty cycle = 50 percent; $f_{IN} \geq 1$ MHz.
 - b. $t_r, t_f = 3$ ns ± 1.0 ns. For input signal generators incapable of maintaining these values of t_r and t_f , the 3.0 ns limit may be increased up to 10 ns, as needed, maintaining the ± 1.0 ns tolerance and guaranteeing the results at 3.0 ns ± 1.0 ns; skew between any two switching inputs signals (t_{sk}): ≤ 250 ps.

FIGURE 4. Ground bounce load circuit and waveforms.

STANDARD MICROCIRCUIT DRAWING DEFENSE ELECTRONICS SUPPLY CENTER DAYTON, OHIO 45444	SIZE A		5962-92259
		REVISION LEVEL	SHEET 13

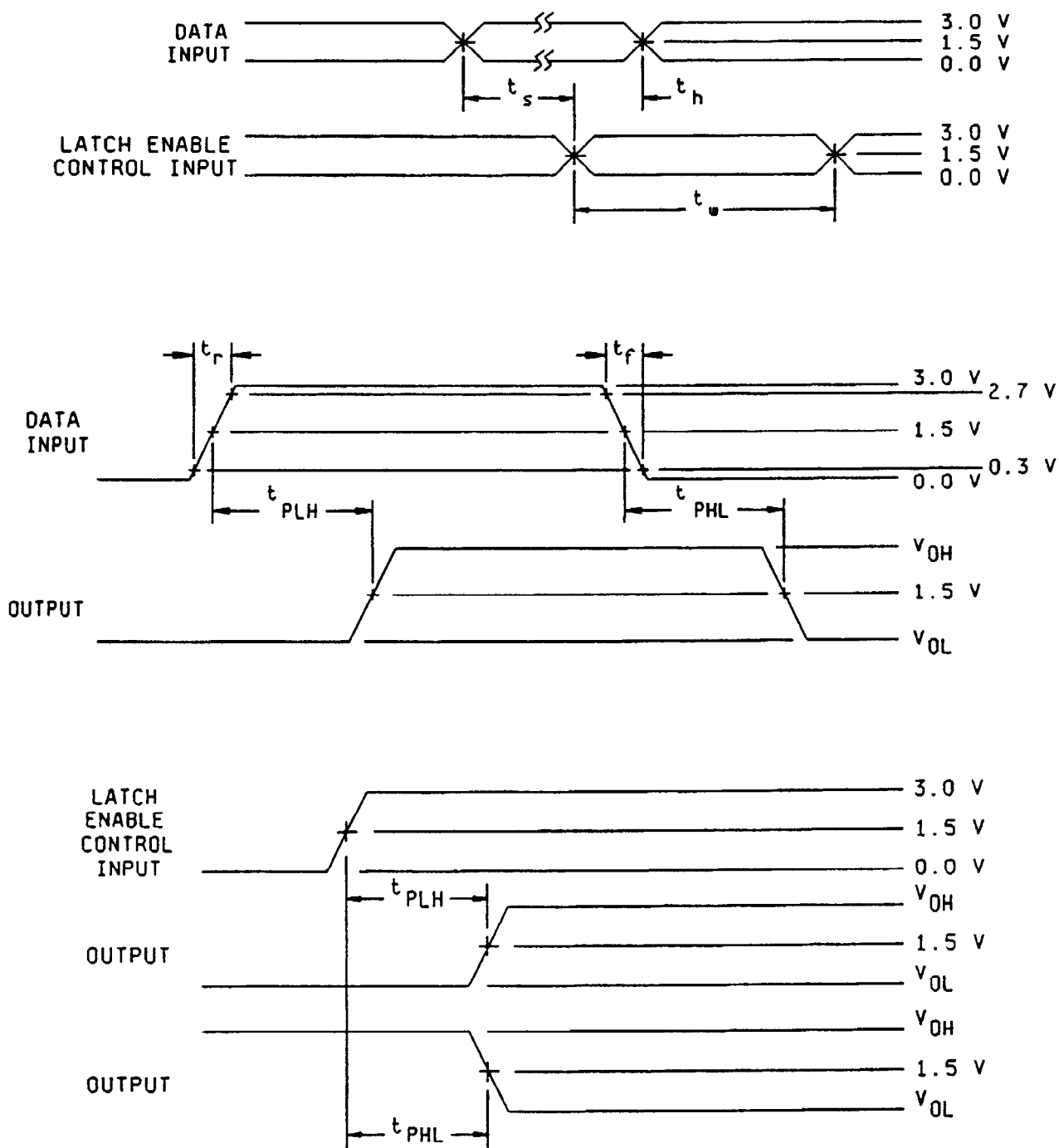

FIGURE 5. Switching waveforms and test circuit.

STANDARD
MICROCIRCUIT DRAWING
DEFENSE ELECTRONICS SUPPLY CENTER
DAYTON, OHIO 45444

SIZE
A

5962-92259

REVISION LEVEL

SHEET
14

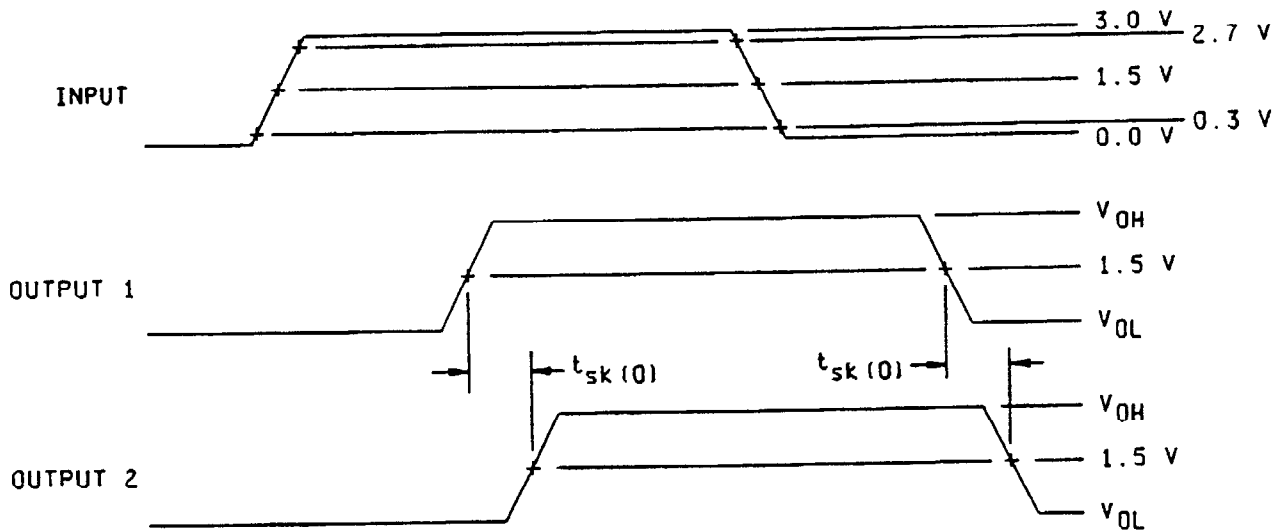
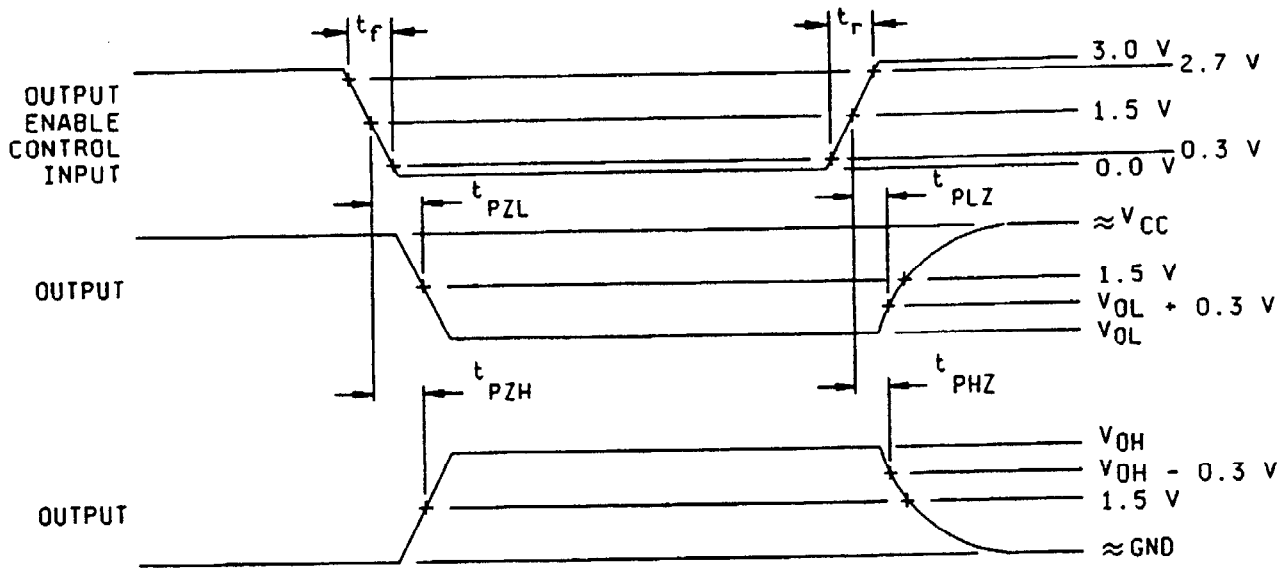
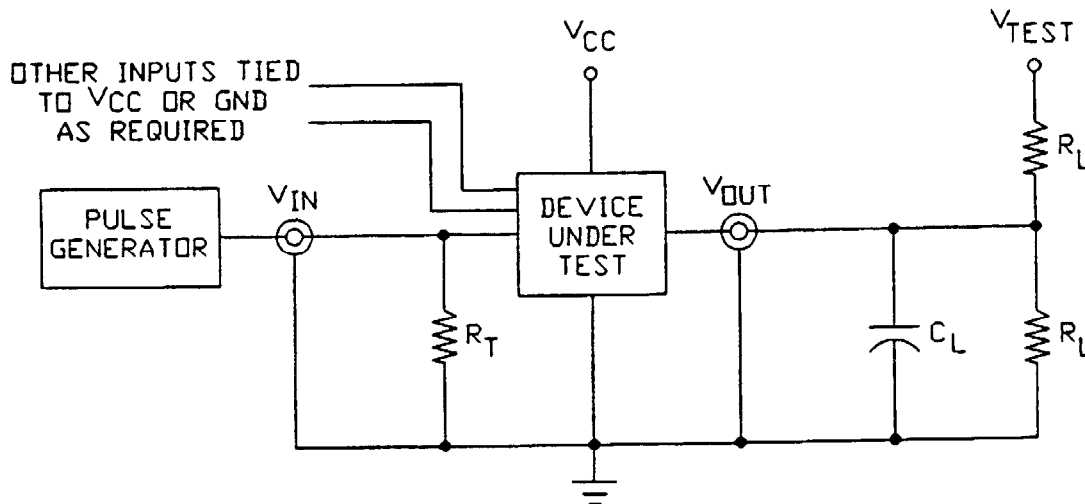

FIGURE 5. Switching waveforms and test circuit - Continued.

STANDARD MICROCIRCUIT DRAWING DEFENSE ELECTRONICS SUPPLY CENTER DAYTON, OHIO 45444	SIZE A		5962-92259
		REVISION LEVEL	SHEET 15



NOTES:

1. When measuring t_{PLZ} and t_{PZL} : $V_{TEST} = 7.0$ V.
2. When measuring t_{PHZ} , t_{PZH} , t_{PLH} , and t_{PHL} : $V_{TEST} =$ open.
3. The t_{PZL} and t_{PLZ} reference waveform is for the output under test with internal conditions such that the output is at V_{OL} except when disabled by the output enable control. The t_{PZH} and t_{PHZ} reference waveform is for the output under test with internal conditions such that the output is at V_{OH} except when disabled by the output enable control.
4. $C_L = 50$ pF minimum or equivalent (includes test jig and probe capacitance).
5. $R_L = 500\Omega$ or equivalent.
6. $R_T = 50\Omega$ or equivalent.
7. Input signal from pulse generator: $V_{IN} = 0.0$ V to 3.0 V; $PRR \leq 10$ MHz; $t_r \leq 2.5$ ns; $t_f \leq 2.5$ ns; t_r and t_f shall be measured from 0.3 V to 2.7 V and from 2.7 V to 0.3 V, respectively; duty cycle = 50 percent.
8. Timing parameters shall be tested at a minimum input frequency of 1 MHz.
9. The outputs are measured one at a time with one transition per measurement.

FIGURE 5. Switching waveforms and test circuit - Continued.

STANDARD MICROCIRCUIT DRAWING DEFENSE ELECTRONICS SUPPLY CENTER DAYTON, OHIO 45444	SIZE A		5962-92259
		REVISION LEVEL	SHEET 16

TABLE II. Electrical test requirements.

Test requirements	Subgroups (in accordance with MIL-STD-883, TM 5005, table I)	Subgroups (in accordance with MIL-I-38535, table III)	
	Device class M	Device class Q	Device class V
Interim electrical parameters (see 4.2)	---	1	1
Final electrical parameters (see 4.2)	1, 2, 3, 4, 5, 6, 7, 8, 9, 10, 11 1/	1, 2, 3, 4, 5, 6, 7, 8, 9, 10, 11 1/	1, 2, 3, 4, 5, 6, 7, 8, 9, 10, 11 2/
Group A test requirements (see 4.4)	1, 2, 3, 4, 5, 6, 7, 8, 9, 10, 11	1, 2, 3, 4, 5, 6, 7, 8, 9, 10, 11	1, 2, 3, 4, 5, 6, 7, 8, 9, 10, 11
Group C end-point electrical parameters (see 4.4)	1, 2, 3, 4, 5, 6	1, 2, 3, 4, 5, 6	1, 2, 3, 4, 5, 6 7, 8, 9, 10, 11
Group D end-point electrical parameters (see 4.4)	1, 2, 3	1, 2, 3	1, 2, 3
Group E end-point electrical parameters (see 4.4)	1, 4, 7, 9	1, 4, 7, 9	1, 4, 7, 9

1/ PDA applies to subgroups 1 and 4 (i.e., I_{CCT} only).

2/ PDA applies to subgroups 1, 4, and 7.

4.2.2 Additional criteria for device classes Q and V.

- a. The burn-in test duration, test condition and test temperature, or approved alternatives shall be as specified in the device manufacturer's QM plan in accordance with MIL-I-38535. The burn-in test circuit shall be maintained under document revision level control of the device manufacturer's Technology Review Board (TRB) in accordance with MIL-I-38535 and shall be made available to the preparing or acquiring activity upon request. The test circuit shall specify the inputs, outputs, biases, and power dissipation, as applicable, in accordance with the intent specified in test method 1015.
- b. Interim and final electrical test parameters shall be as specified in table II herein.
- c. Additional screening for device class V beyond the requirements of device class Q shall be as specified in appendix B of MIL-I-38535.

4.3 Qualification inspection for device classes Q and V. Qualification inspection for device classes Q and V shall be in accordance with MIL-I-38535. Inspections to be performed shall be those specified in MIL-I-38535 and herein for groups A, B, C, D, and E inspections (see 4.4.1 through 4.4.4).

4.3.1 Electrostatic discharge sensitivity qualification inspection. Electrostatic discharge sensitivity (ESDS) testing shall be performed in accordance with MIL-STD-883, method 3015. ESDS testing shall be measured only for initial qualification and after process or design changes which may affect ESDS classification.

4.4 Conformance inspection. Quality conformance inspection for device class M shall be in accordance with MIL-STD-883 (see 3.1 herein) and as specified herein. Inspections to be performed for device class M shall be those specified in method 5005 of MIL-STD-883 and herein for groups A, B, C, D, and E inspections (see 4.4.1 through 4.4.4). Technology conformance inspection for classes Q and V shall be in accordance with MIL-I-38535 including groups A, B, C, D, and E inspections and as specified herein except where option 2 of MIL-I-38535 permits alternate in-line control testing.

STANDARD MICROCIRCUIT DRAWING DEFENSE ELECTRONICS SUPPLY CENTER DAYTON, OHIO 45444	SIZE A		5962-92259
		REVISION LEVEL	SHEET 17

4.4.1 Group A inspection.

- a. Tests shall be as specified in table II herein.
- b. C_{IN} and C_{OUT} shall be measured only for initial qualification and after process or design changes which may affect capacitance. C_{IN} and C_{OUT} shall be measured between the designated terminal and GND at a frequency of 1 MHz. For C_{IN} and C_{OUT} , test all applicable pins on five devices with zero failures.

For C_{IN} and C_{OUT} , a device manufacturer may qualify devices by functional groups. A specific functional group shall be composed of function types, that by design, will yield the same capacitance values when tested in accordance with table I herein. The device manufacturer shall set a functional group limit for the C_{IN} and C_{OUT} tests. The device manufacturer may then test one device function from a functional group to the limits and conditions specified herein. All other device functions in that particular functional group shall be guaranteed, if not tested, to the limits and conditions specified in table I herein. The device manufacturer shall submit to DESC-EC the device functions listed in each functional group and the test results for each device tested.

- c. For device class M, subgroups 7 and 8 tests shall be sufficient to verify the truth table in figure 2 herein. The test vectors used to verify the truth table shall, at a minimum, test all functions of each input and output. All possible input to output logic patterns per function shall be guaranteed, if not tested, to the truth table in figure 2 herein. For device classes Q and V, subgroups 7 and 8 shall include verifying the functionality of the device; these tests shall have been fault graded in accordance with MIL-STD-883, test method 5012 (see 1.5 herein).
- d. Ground and V_{CC} bounce tests are required for all device classes. These tests shall be performed only for initial qualification, after process or design changes which may affect the performance of the device, and any changes to the test fixture. V_{OLP} , V_{OLV} , V_{OHP} , and V_{OHV} shall be measured for the worst case outputs of the device. All other outputs shall be guaranteed, if not tested, to the limits established for the worst case outputs. The worst case outputs tested are to be determined by the manufacturer. Test 5 devices assembled in the worst case package type supplied to this document. All other package types shall be guaranteed, if not tested, to the limits established for the worst case package. The package type to be tested shall be determined by the manufacturer. The device manufacturer will submit to DESC-EC data that shall include all measured peak values for each device tested and detailed oscilloscope plots for each V_{OLP} , V_{OLV} , V_{OHP} , and V_{OHV} from one sample part per function. The plot shall contain the waveforms of both a switching output and the output under test.

Each device manufacturer shall test product on the fixtures they currently use. When a new fixture is used, the device manufacturer shall inform DESC-EC of this change and test the 5 devices on both the new and old test fixtures. The device manufacturer shall then submit to DESC-EC data from testing on both fixtures that shall include all measured peak values for each device tested and detailed oscilloscope plots for each V_{OLP} , V_{OLV} , V_{OHP} , and V_{OHV} from one sample part per function. The plot shall contain the waveforms of both a switching output and the output under test.

For V_{OLP} , V_{OLV} , V_{OHP} , and V_{OHV} , a device manufacturer may qualify devices by functional groups. A specific functional group shall be composed of function types, that by design, will yield the same test values when tested in accordance with table I herein. The device manufacturer shall set a functional group limit for the V_{OLP} , V_{OLV} , V_{OHP} , and V_{OHV} tests. The device manufacturer may then test one device function from a functional group to the limits and conditions specified herein. All other device functions in that particular functional group shall be guaranteed, if not tested, to the limits and conditions specified in table I herein. The device manufacturer shall submit to DESC-EC the device functions listed in each functional group and the test results, along with the oscilloscope plots, for each device tested.

4.4.2 Group C inspection. The group C inspection end-point electrical parameters shall be as specified in table II herein.

4.4.2.1 Additional criteria for device class M. Steady-state life test conditions, method 1005 of MIL-STD-883:

- a. Test condition A, B, C or D. The test circuit shall be maintained by the manufacturer under document revision level control and shall be made available to the preparing or acquiring activity upon request. The test circuit shall specify the inputs, outputs, biases, and power dissipation, as applicable, in accordance with the intent specified in test method 1005.
- b. $T_A = +125^\circ\text{C}$, minimum.

STANDARD MICROCIRCUIT DRAWING DEFENSE ELECTRONICS SUPPLY CENTER DAYTON, OHIO 45444	SIZE A		5962-92259
		REVISION LEVEL	SHEET 18

c. Test duration: 1,000 hours, except as permitted by method 1005 of MIL-STD-883.

4.4.2.2 Additional criteria for device classes Q and V. The steady-state life test duration, test condition and test temperature, or approved alternatives shall be as specified in the device manufacturer's QM plan in accordance with MIL-I-38535. The test circuit shall be maintained under document revision level control of the device manufacturer's TRB in accordance with MIL-I-38535 and shall be made available to the preparing or acquiring activity upon request. The test circuit shall specify the inputs, outputs, biases, and power dissipation, as applicable, in accordance with the intent specified in test method 1005.

4.4.3 Group D inspection. The group D inspection end-point electrical parameters shall be as specified in table II herein.

4.4.4 Group E inspection. Group E inspection is required only for parts intended to be marked as radiation hardness assured (see 3.5 herein). RHA levels for device classes Q and V shall be M, D, R, and H and RHA levels for device class M shall be M and D.

- a. End-point electrical parameters shall be as specified in table II herein.
- b. For device class M, the devices shall be subjected to radiation hardness assured tests as specified in MIL-I-38535, appendix A, for the RHA level being tested. For device classes Q and V, the devices or test vehicle shall be subjected to radiation hardness assured tests as specified in MIL-I-38535 for the RHA level being tested. All device classes must meet the postirradiation end-point electrical parameter limits as defined in table I at $T_A = +25^\circ\text{C} \pm 5^\circ\text{C}$, after exposure, to the subgroups specified in table II herein.
- c. When specified in the purchase order or contract, a copy of the RHA delta limits shall be supplied.

4.5 Methods of inspection. Methods of inspection shall be specified as follows:

4.5.1 Voltage and current. Unless otherwise specified, all voltages given are referenced to the microcircuit GND terminal. Currents given are conventional current and positive when flowing into the referenced terminal.

5. PACKAGING

5.1 Packaging requirements. The requirements for packaging shall be in accordance with MIL-STD-883 (see 3.1 herein) for device class M and MIL-I-38535 for device classes Q and V.

6. NOTES

6.1 Intended use. Microcircuits conforming to this drawing are intended for use for Government microcircuit applications (original equipment), design applications, and logistics purposes.

6.1.1 Replaceability. Microcircuits covered by this drawing will replace the same generic device covered by a contractor-prepared specification or drawing.

6.1.2 Substitutability. Device class Q devices will replace device class M devices.

6.2 Configuration control of SMD's. All proposed changes to existing SMD's will be coordinated with the users of record for the individual documents. This coordination will be accomplished in accordance with MIL-STD-973 using DD Form 1692, Engineering Change Proposal.

6.3 Record of users. Military and industrial users shall inform Defense Electronics Supply Center when a system application requires configuration control and which SMD's are applicable to that system. DESC will maintain a record of users and this list will be used for coordination and distribution of changes to the drawings. Users of drawings covering microelectronic devices (FSC 5962) should contact DESC-EC, telephone (513) 296-6047.

6.4 Comments. Comments on this drawing should be directed to DESC-EC, Dayton, Ohio 45444-5270, or telephone (513) 296-5377.

STANDARD MICROCIRCUIT DRAWING DEFENSE ELECTRONICS SUPPLY CENTER DAYTON, OHIO 45444	SIZE A		5962-92259
		REVISION LEVEL	SHEET 19

6.5 Abbreviations, symbols, and definitions. The abbreviations, symbols, and definitions used herein are defined in MIL-I-38535 and MIL-STD-1331, and as follows:

GND - - - - - Ground zero voltage potential.
 I_{CC} - - - - - Quiescent supply current.
 I_{IL} - - - - - Input current low.
 I_{IH} - - - - - Input current high.
 T_C - - - - - Case temperature.
 T_A - - - - - Ambient temperature.
 V_{CC} - - - - - Positive supply voltage.
 C_{IN} - - - - - Input terminal-to-GND capacitance.
 C_{OUT} - - - - - Output terminal-to-GND capacitance.
 V_{IC-} - - - - - Negative input clamp voltage.

6.6 One part - one part number system. The one part - one part number system described below has been developed to allow for transitions between identical generic devices covered by the three major microcircuit requirements documents (MIL-H-38534, MIL-I-38535, and 1.2.1 of MIL-STD-883) without the necessity for the generation of unique PIN's. The three military requirements documents represent different class levels, and previously when a device manufacturer upgraded military product from one class level to another, the benefits of the upgraded product were unavailable to the Original Equipment Manufacturer (OEM), that was contractually locked into the original unique PIN. By establishing a one part number system covering all three documents, the OEM can acquire to the highest class level available for a given generic device to meet system needs without modifying the original contract parts selection criteria.

<u>Military documentation format</u>	<u>Example PIN under new system</u>	<u>Manufacturing source listing</u>	<u>Document Listing</u>
New MIL-H-38534 Standard Microcircuit Drawings	5962-XXXXXZZ(H or K)YY	QML-38534	MIL-BUL-103
New MIL-I-38535 Standard Microcircuit Drawings	5962-XXXXXZZ(Q or V)YY	QML-38535	MIL-BUL-103
New 1.2.1 of MIL-STD-883 Standard Microcircuit Drawings.	5962-XXXXXZZ(M)YY	MIL-BUL-103	MIL-BUL-103

6.7 Sources of supply.

6.7.1 Sources of supply for device classes Q and V. Sources of supply for device classes Q and V are listed in QML-38535. The vendors listed in QML-38535 have submitted a certificate of compliance (see 3.6 herein) to DESC-EC and have agreed to this drawing.

6.7.2 Approved sources of supply for device class M. Approved sources of supply for class M are listed in MIL-BUL-103. The vendors listed in MIL-BUL-103 have agreed to this drawing and a certificate of compliance (see 3.6 herein) has been submitted to and accepted by DESC-EC.

STANDARD MICROCIRCUIT DRAWING DEFENSE ELECTRONICS SUPPLY CENTER DAYTON, OHIO 45444	SIZE A		5962-92259
		REVISION LEVEL	SHEET 20

STANDARDIZED MILITARY DRAWING SOURCE APPROVAL BULLETIN

DATE: 94-09-22

Approved sources of supply for SMD 5962-92259 are listed below for immediate acquisition only and shall be added to MIL-BUL-103 during the next revision. MIL-BUL-103 will be revised to include the addition or deletion of sources. The vendors listed below have agreed to this drawing and a certificate of compliance has been submitted to and accepted by DESC-EC. This bulletin is superseded by the next dated revision of MIL-BUL-103.

Standardized military drawing PIN	Vendor CAGE number	Vendor similar PIN 1/
5962-9225901MXX	61772	IDT54FCT16373TEB
5962-9225902MXX	61772	IDT54FCT16373ATEB
5962-9225903MXX	61772	IDT54FCT16373CTEB

1/ Caution. Do not use this number for item acquisition. Items acquired to this number may not satisfy the performance requirements of this drawing.

Vendor CAGE number

61772

Vendor name and address

Integrated Devices Technology Inc
 3236 Scott Boulevard
 P.O. Box 58015
 Santa Clara, CA 95052

The information contained herein is disseminated for convenience only and the Government assumes no liability whatsoever for any inaccuracies in the information bulletin.