

3.3V, High Bandwidth, Hot Insertion, 4-Bit, 2-Port Bus Switch with Individual Enables

Product Features

- Near zero propagation delay
- 5Ω switches connect inputs to outputs
- High Bandwidth (>200 MHz)
- Rail-to-Rail, 3.3V Switching
- 5V I/O Tolerant
- Permits Hot Insertion
- Packages available:
 - 14-pin 150 mil wide plastic SOIC (W14)
 - 16-pin 150 mil wide plastic QSOP (Q16)

Applications

- High Bandwidth Data Switching
- Hot Docking

Product Description

Pericom Semiconductor’s PI3C series of logic circuits are produced using the Company’s advanced sub micron CMOS technology, achieving industry leading speed grades.

The PI3C3125A and PI3C3126A are 3.3 Volt, 4-bit bus switches designed with four individual 5Ω bus switches with fast individual enables in an industry standard 74XX125/126 pinout. When enabled via the associated Bus Enable (BE) pin, the “A” pin is directly connected to the “B” pin for that particular gate. The bus switch introduces no additional propagation delay or additional ground bounce noise.

The PI3C3125 device has active LOW enables, and the PI3C3126A has active HIGH enables. It is very useful in switching signals that have high bandwidth (>200 MHz).

PI3C3125 Logic Block Diagram

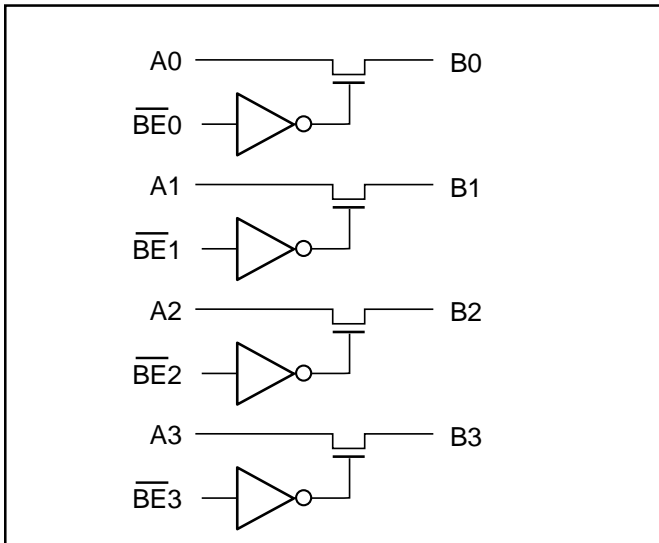

PI3C3126 Logic Block Diagram

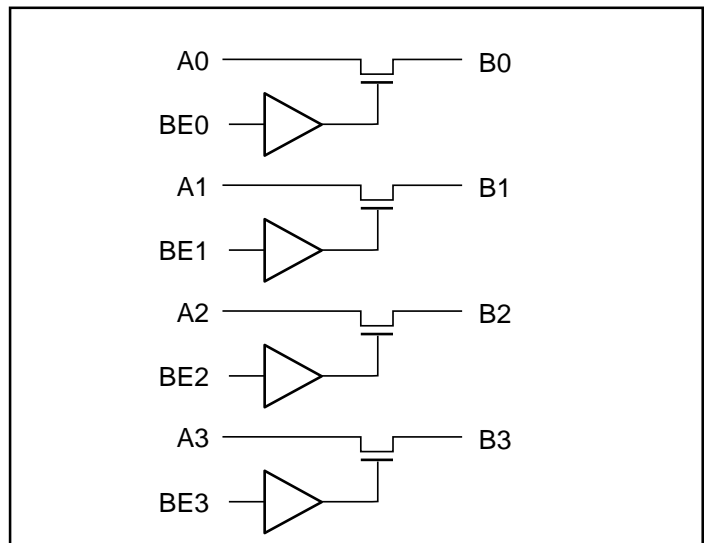

Maximum Ratings

(Above which the useful life may be impaired. For user guidelines, not tested.)

Storage Temperature	-65°C to +150°C
Ambient Temperature with Power Applied	-40°C to +85°C
Supply Voltage to Ground Potential (Inputs & V _{CC} Only) ...	-0.5V to +4.6V
Supply Voltage to Ground Potential (Outputs & D/O Only) .	-0.5V to +4.6V
DC Input Voltage	-0.5V to +4.6V
DC Output Current	120mA
Power Dissipation	0.5W

Note:

Stresses greater than those listed under MAXIMUM RATINGS may cause permanent damage to the device. This is a stress rating only and functional operation of the device at these or any other conditions above those indicated in the operational sections of this specification is not implied. Exposure to absolute maximum rating conditions for extended periods may affect reliability.

PI3C3125 14-Pin Product Pin Configuration

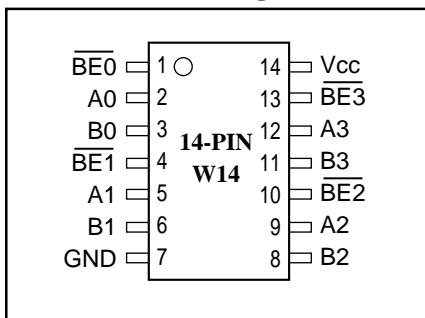

PI3C3126 14-Pin Product Pin Configuration

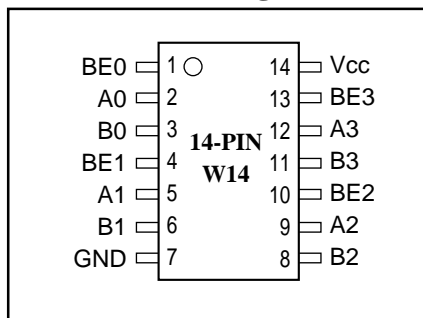

PI3C3125 16-Pin Product Pin Configuration

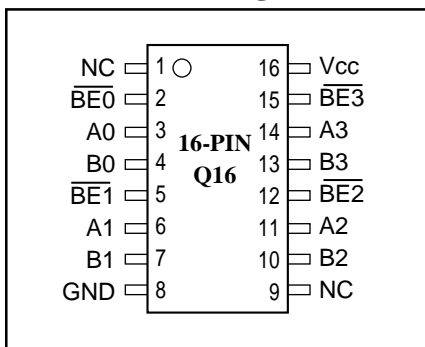

PI3C3126 16-Pin Product Pin Configuration

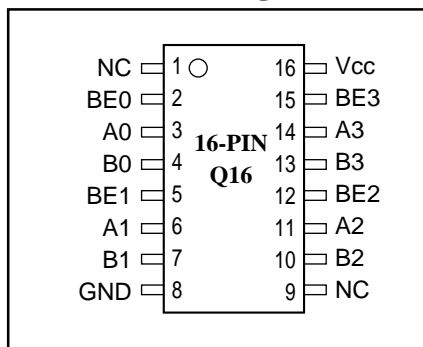

Product Pin Description

Pin Name	Description
\overline{BEn}	Switch Enable (PI3C3125)
BEn	Switch Enable (PI3C3126)
A3-A0	Bus A
B3-B0	Bus B
V _{CC}	Power
GND	Ground

Truth Table⁽¹⁾

PI3C3125 \overline{BEn}	PI3C3126 BEn	A _n	B _n	V _{CC}	Function
X*	X	Hi-Z	Hi-Z	GND	Disconnect
H	L	Hi-Z	Hi-Z	V _{CC}	Disconnect
L	H	B _n	A _n	V _{CC}	Connect

Note:

- H = High Voltage Level, L = Low Voltage Level
 HI-Z = High Impedance, X = Don't Care

* A pull-up resistor should be provided for power-up protection.

DC Electrical Characteristics (Over the Operating Range, $T_A = -40^\circ\text{C}$ to $+85^\circ\text{C}$, $V_{CC} = 3.3\text{V} \pm 10\%$)

Parameters	Description	Test Conditions ⁽¹⁾	Min.	Typ. ⁽²⁾	Max.	Units
V_{IH}	Input HIGH Voltage	Guaranteed Logic HIGH Level	2.0			V
V_{IL}	Input LOW Voltage	Guaranteed Logic LOW Level	-0.5		0.8	
I_{IH}	Input HIGH Current	$V_{CC} = \text{Max.}, V_{IN} = V_{CC}$			± 1	μA
I_{IL}	Input LOW Current	$V_{CC} = \text{Max.}, V_{IN} = \text{GND}$			± 1	
I_{OZH}	High Impedance Output Current	$0 \leq A, B \leq V_{CC}$			± 1	
V_{IK}	Clamp Diode Voltage	$V_{CC} = \text{Min.}, I_{IN} = -18\text{mA}$		-0.73	-1.2	V
R_{ON}	Switch On Resistance ⁽⁴⁾	$V_{CC} = \text{Min.}, V_{IN} = 0.0\text{V}, I_{ON} = 48\text{mA}$ or 60mA $V_{CC} = \text{Min.}, V_{IN} = 2.4\text{V}, I_{ON} = 15\text{mA}$		5 8	7 15	Ω

Capacitance ($T_A = 25^\circ\text{C}$, $f = 1\text{ MHz}$)

Parameters ⁽⁵⁾	Description	Test Conditions	Typ.	Units
C_{IN}	Input Capacitance	$V_{IN} = 0\text{V}$	3.5	pF
C_{OFF}	A/B Capacitance, Switch Off	$V_{IN} = 0\text{V}$	5.0	
C_{ON}	A/B Capacitance, Switch On	$V_{IN} = 0\text{V}$	10.0	

Notes:

1. For Max. or Min. conditions, use appropriate value specified under Electrical Characteristics for the applicable device type.
2. Typical values are at $V_{CC} = 3.3\text{V}$, $T_A = 25^\circ\text{C}$ ambient and maximum loading.
3. Not more than one output should be shorted at one time. Duration of the test should not exceed one second.
4. Measured by the voltage drop between A and B pin at indicated current through the switch. ON resistance is determined by the lower of the voltages on the two (A,B) pins.
5. This parameter is determined by device characterization but is not production tested.

Power Supply Characteristics

Parameters	Description	Test Conditions ⁽¹⁾		Min.	Typ. ⁽²⁾	Max.	Units
I_{CC}	Quiescent Power Supply Current	$V_{CC} = \text{Max.}$	$V_{IN} = \text{GND}$ or V_{CC}		260	500	μA
ΔI_{CC}	Supply Current per Input HIGH	$V_{CC} = \text{Max.}$	$V_{IN} = 3.0\text{V}$ ⁽³⁾			750	

Notes:

1. For Max. or Min. conditions, use appropriate value specified under Electrical Characteristics for the applicable device.
2. Typical values are at $V_{CC} = 3.3\text{V}$, $+25^\circ\text{C}$ ambient.
3. Per driven input (control input only); A and B pins do not contribute to ΔI_{CC} .
4. This current applies to the control inputs only and represent the current required to switch internal capacitance at the specified frequency. The A and B inputs generate no significant AC or DC currents as they transition. This parameter is not tested, but is guaranteed by design.

PI3C3125 Switching Characteristics over Operating Range

Parameters	Description	Conditions ⁽¹⁾	PI3C3125		Units
			Com.		
			Min.	Max.	
tPLH tPHL	Propagation Delay ^(2,3) Ax to Bx, Bx to Ax	C _L = 50 pF, R _L = 500Ω		0.25	ns
tPZH tPZL	Bus Enable Time	C _L = 50 pF, R _L = 500Ω,	1.5	6.5	
tPHZ tPLZ	Bus Disable Time	R = 500Ω	1.5	5.5	

PI3C3126 Switching Characteristics over Operating Range

Parameters	Description	Conditions ⁽¹⁾	PI3C3126		Units
			Com.		
			Min.	Max.	
tPLH tPHL	Propagation Delay ^(2,3) A to B, B to A	C _L = 50 pF, R _L = 500Ω		0.25	ns
tPZH tPZL	Bus Enable Time	C _L = 50 pF, R _L = 500Ω,	1.5	6.5	
tPHZ tPLZ	Bus Disable Time	R = 500Ω	1.5	5.5	

Notes:

1. See test circuit and waveforms.
2. This parameter is guaranteed but not tested on Propagation Delays.
3. The bus switch contributes no propagational delay other than the RC delay of the ON resistance of the switch and the load capacitance. The time constant for the switch alone is of the order of 0.25ns for 50pF load. Since this time constant is much smaller than the rise/fall times of typical driving signals, it adds very little propagational delay to the system. Propagational delay of the bus switch when used in a system is determined by the driving circuit on the driving side of the switch and its interaction with the load on the driven side.