

7410, 7411, LS10, LS11, S10, S11 Gates

Logic Products

Triple Three-Input NAND ('10), AND ('11) Gates
Product Specification

TYPE	TYPICAL PROPAGATION DELAY	TYPICAL SUPPLY CURRENT (TOTAL)
7410	9ns	6mA
74LS10	10ns	1.2mA
74S10	3ns	12mA
7411	10ns	11mA
74LS11	9ns	2.6mA
74S11	5ns	19mA

FUNCTION TABLE

INPUTS			OUTPUTS	
A	B	C	Y('10)	Y('11)
L	L	L	H	L
L	L	H	H	L
L	H	L	H	L
L	H	H	H	L
H	L	L	H	L
H	L	H	H	L
H	H	L	H	L
H	H	H	L	H

H = HIGH voltage level
L = LOW voltage level

ORDERING CODE

PACKAGES	COMMERCIAL RANGE $V_{CC} = 5V \pm 5\%$; $T_A = 0^\circ C$ to $+70^\circ C$
Plastic DIP '10	N7410N, N74LS10N, N74S10N
'11	N7411N, N74LS11N, N74S11N
Plastic SO '10	N74LS10D, N74S10D
Plastic SO '11	N74LS11D, N74S11D

NOTE:

For information regarding devices processed to Military Specifications, see the Signetics Military Products Data Manual.

INPUT AND OUTPUT LOADING AND FAN-OUT TABLE

PINS	DESCRIPTION	74	74S	74LS
A - C	Inputs	1ul	1Sul	1LSul
Y	Output	10ul	10Sul	10LSul

NOTE:

Where a 74 unit load (ul) is understood to be $40\mu A I_{IH}$ and $-1.6mA I_{IL}$, a 74S unit load (Sul) is $50\mu A I_{IH}$ and $-2.0mA I_{IL}$, and 74LS unit load (LSul) is $20\mu A I_{IH}$ and $-0.4mA I_{IL}$.

PIN CONFIGURATION

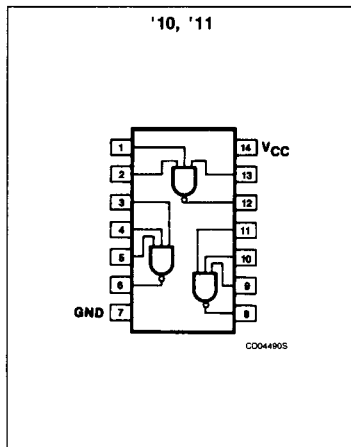

LOGIC SYMBOL

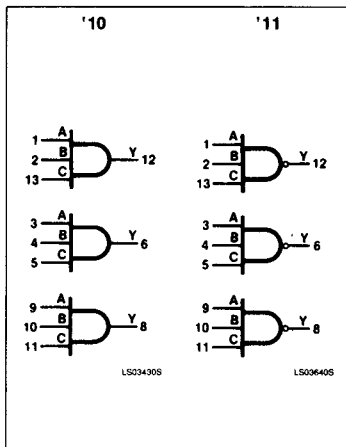

LOGIC SYMBOL (IEEE/IEC)

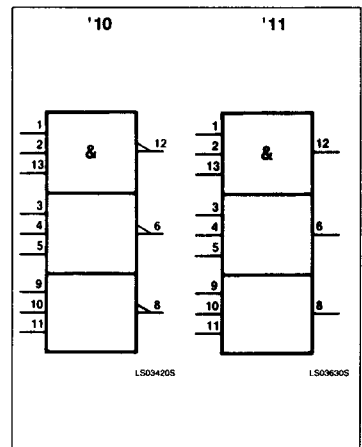

Gates

7410, 7411, LS10, LS11, S10, S11

ABSOLUTE MAXIMUM RATINGS (Over operating free-air temperatures unless otherwise noted.)

PARAMETER	74	74LS	74S	UNIT
V _{CC} Supply voltage	7.0	7.0	7.0	V
V _{IN} Input voltage	-0.5 to +5.5	-0.5 to +5.5	-0.5 to +5.5	V
I _{IN} Input current	-30 to +5	-30 to +1	-30 to +5	mA
V _{OUT} Voltage applied to output in HIGH output state	-0.5 to +V _{CC}	-0.5 to +V _{CC}	-0.5 to +V _{CC}	V
T _A Operating free-air temperature range	0 to 70			°C

RECOMMENDED OPERATING CONDITIONS

PARAMETER		74			74LS			74S			UNIT
		Min	Nom	Max	Min	Nom	Max	Min	Nom	Max	
V _{CC} Supply voltage	Com'l	4.75	5.0	5.25	4.75	5.0	5.25	4.75	5.0	5.25	V
V _{IH} HIGH-level input voltage		2.0			2.0			2.0			V
V _{IL} LOW-level input voltage	Com'l			+0.8			+0.8			+0.8	V
I _{IK} Input clamp current				-12			-18			-18	mA
I _{OH} HIGH-level output current	'10			-400			-400			-1000	μA
	'11			-800			-400			-1000	μA
I _{OL} LOW-level output current	Com'l			16			8			20	mA
T _A Operating free-air temperature	Com'l	0		70	0		70	0		70	°C

5

Gates

7410, 7411, LS10, LS11, S10, S11

DC ELECTRICAL CHARACTERISTICS (Over recommended operating free-air temperature range unless otherwise noted.)

PARAMETER	TEST CONDITIONS ¹	7410, 11			74LS10, 11			74S10, 11			UNIT	
		Min	Typ ²	Max	Min	Typ ²	Max	Min	Typ ²	Max		
V _{OH}	HIGH-level output voltage V _{CC} = MIN, V _{IL} = MAX, V _{IH} = MIN, I _{OH} = MAX	2.4	3.4		2.7	3.4		2.7	3.4		V	
V _{OL}	LOW-level output voltage V _{CC} = MIN, V _{IH} = MIN	I _{OL} = MAX			0.2	0.4		0.35	0.5		0.5	V
		I _{OL} = 4mA (74LS)						0.25	0.4			V
V _{IK}	Input clamp voltage V _{CC} = MIN, I _I = I _{IK}				-1.5			-1.5			-1.2	V
I _I	Input current at maximum input voltage V _{CC} = MAX	V _I = 5.5V				1.0					1.0	mA
		V _I = 7.0V						0.1				mA
I _{IH}	HIGH-level input current V _{CC} = MAX	V _I = 2.4V				40						μA
		V _I = 2.7V						20			50	μA
I _{IL}	LOW-level input current V _{CC} = MAX	V _I = 0.4V				-1.6		-0.4				mA
		V _I = 0.5V									-2.0	mA
I _{OS}	Short-circuit output current ³ V _{CC} = MAX	-18		-55	-20		-100	-40		-100	mA	
I _{CC}	Supply current (total) V _{CC} = MAX	I _{CCH} Outputs HIGH	'10	3	6		0.6	1.2		7.5	12	mA
		I _{CCL} Outputs LOW		9	16.5		1.8	3.3		15	27	mA
		I _{CCH} Outputs HIGH	'11	6	12		1.8	3.6		13.5	24	mA
		I _{CCL} Outputs LOW		15	20		3.3	6.6		24	42	mA

NOTES:

- For conditions shown as MIN or MAX, use the appropriate value specified under recommended operating conditions for the applicable type.
- All typical values are at V_{CC} = 5V, T_A = 25°C.
- I_{OS} is tested with V_{OUT} = +0.5V and V_{CC} = V_{CC} MAX + 0.5V. Not more than one output should be shorted at a time and duration of the short circuit should not exceed one second.

AC WAVEFORMS

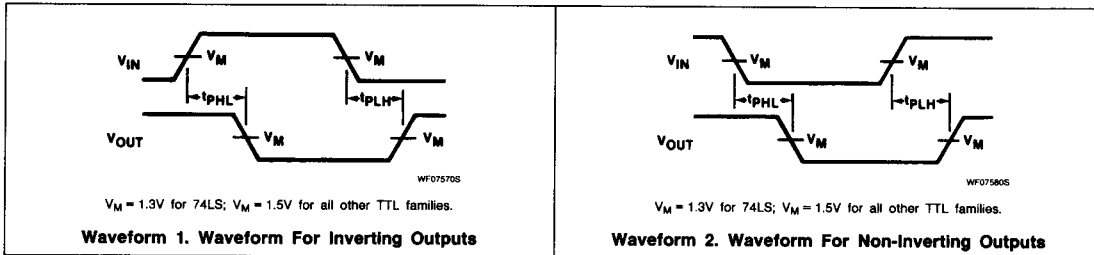

Gates

7410, 7411, LS10, LS11, S10, S11

AC ELECTRICAL CHARACTERISTICS $T_A = 25^\circ\text{C}$, $V_{CC} = 5.0\text{V}$

PARAMETER	TEST CONDITIONS	74		74LS		74S		UNIT
		$C_L = 15\text{pF}$, $R_L = 400\Omega$		$C_L = 15\text{pF}$, $R_L = 2\text{k}\Omega$		$C_L = 15\text{pF}$, $R_L = 280\Omega$		
		Min	Max	Min	Max	Min	Max	
t_{PLH} t_{PHL} Propagation delay	Waveform 1, '10		22 15		15 15		4.5 5.0	ns
t_{PLH} t_{PHL} Propagation delay	Waveform 2, '11		27 19		15 20		7.0 7.5	ns

TEST CIRCUITS AND WAVEFORMS

TC028405

WF064505

$V_M = 1.3\text{V}$ for 74LS; $V_M = 1.5\text{V}$ for all other TTL families.

Input Pulse Definitions

FAMILY	INPUT PULSE REQUIREMENTS				
	Amplitude	Rep. Rate	Pulse Width	t_{TLH}	t_{THL}
74	3.0V	1MHz	500ns	7ns	7ns
74LS	3.0V	1MHz	500ns	15ns	6ns
74S	3.0V	1MHz	500ns	2.5ns	2.5ns

Test Circuit For 74 Totem-Pole Outputs

DEFINITIONS

R_L = Load resistor to V_{CC} ; see AC CHARACTERISTICS for value.

C_L = Load capacitance includes jig and probe capacitance; see AC CHARACTERISTICS for value.

R_T = Termination resistance should be equal to Z_{OUT} of Pulse Generators.

D = Diodes are 1N916, 1N3064, or equivalent.

t_{TLH} , t_{THL} Values should be less than or equal to the table entries.