

DESCRIPTION	KEY FEATURES
<p>LX23108AL - is a compact 8 Ports White or RGB back light LED Driver, to be used in large display notebooks, LCD monitors, and TV sets. It is designed to work together with the LX24132 LED Controller as a chipset, driving up to 32 LED strings with a variable current of up to 200mA peak. In addition, the LX23108AL provides the LX24132 LED Controller with its ports voltage samples, that facilitate the control of the LED strings supply voltage through an external DC/DC converter; minimizing the power dissipation while regulating the LED currents for all 8 strings. Current regulation is maintained within a ± 3 percent.</p> <p>The LX23108AL LED Driver includes 8 High Bandwidth Current Limiter Cells with PWM Control (ON/OFF Signal).</p> <p>The chip is designed to operate with external Sense Resistors. Such configuration provides maximum flexibility for system designers when scaling up or down the LED currents for meeting a wide range of high accuracy application requirements.</p> <p>IMPORTANT: For the most current data, consult MICROSEMI's website: http://www.microsemi.com</p>	<p>The LX23108AL LED Driver enables a wide dimming range, achieved through a combination of LED current amplitude and PWM duty-cycle control. In addition, the chipset provides a thermally robust solution through advanced system control; including Drain Voltage Sensing for Open/Shorts events and per string Thermal Protection monitoring.</p> <p>The LX23108AL LED Driver is housed in a 32 pin, 5mmx5mm QFN package.</p> <ul style="list-style-type: none"> • White LED, or RGB Backlight Driver for Large Size Display Panels • Up to 8 LED Strings With $\pm 0.5\%$ Precision Current Matching. • Wide Dimming Ratio with PWM Duty-Cycle and LED Current Amplitude Controls. • 12 bit PWM Duty-cycle Resolution – Controlled by LX24132, LX24132A or the LX24232 LED Controllers. • 8 bit Resolution for LED Current Setting – Controlled by LX24132, LX24132A or the LX24232 LED Controllers. • Open String, Short LED and Over-Temperature Protection Per Individual Channel.
APPLICATIONS	
<ul style="list-style-type: none"> • LCD Monitor and TV • Large Signage Display 	

PACKAGE ORDER INFO		THERMAL DATA
T_A (°C)	MLPQ Plastic 5 x5mm 32 pin RoHS Compliant / Pb-free / MSL 1	27.5 ° C/W According to the JESD51-7 THERMAL RESISTANCE-JUNCTION TO AMBIENT
	LX23108ALILQ	Junction Temperature Calculation: $T_J = T_A + (P_D \times \theta_{JA})$. The θ_{JA} numbers are guidelines for the thermal performance of the device/pc-board system. All of the above assume no ambient airflow.
Note: Available in Tape & Reel. Append the letters "TR" to the part number. (i.e. LX23108ALILQ-TR)		

ABSOLUTE MAXIMUM RATINGS

V _{CC} Supply Input Voltage	-0.5V to 5.5V
V _{IO} Supply Input Voltage	-0.5V to 4.5V
LED Pins.....	-0.3V to 70V
All other pins	-0.5V to V _{IO} +0.3 up to 4.5V
Operating Ambient Temperature Range.....	-40 to 85°C
Maximum Operating Junction Temperature.....	150°C
ESD Protection at all I/O pins*.....	+/- 2KV HBM
Storage Temperature Range.....	-65°C to 150°C
Package Peak Temperature for Solder Reflow (40 seconds maximum exposure).....	260°C(+0,-5)

Notes: Exceeding these ratings could cause damage to the device. All voltages are with respect to Ground. Currents are positive into, negative out of specified terminal.

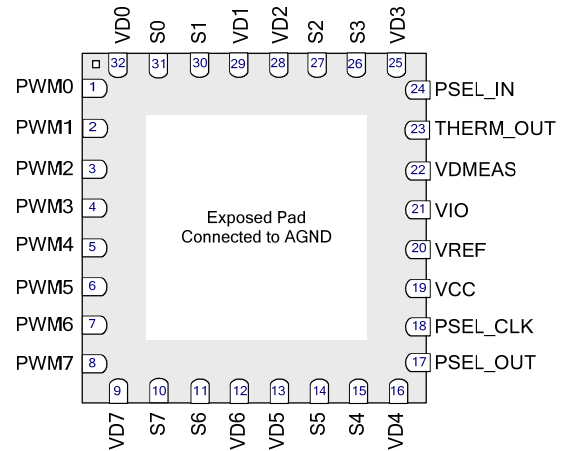
PACKAGE PIN OUT

(Top View)

RoHS / Pb-free Matte Tin Finish / MSL 1

ELECTRICAL CHARACTERISTICS

The following specifications apply over the operating ambient temperature $-40^{\circ}\text{C} \leq T_{\text{AMB}} \leq 85^{\circ}\text{C}$ except where otherwise noted and the following test conditions: $V_{\text{CC}} = 5.0\text{V}$. Performance must be guaranteed for $0^{\circ}\text{C} \leq T_{\text{J}} \leq 110^{\circ}\text{C}$

Parameter	Symbol	Test Conditions / Comment	Min	Typ	Max	Units
Power Supply						
Input Voltage	V _{IO}		3.0	3.3	3.6	V
Operating Current	I _{IO}	V _{IO} = 3.3V, All PWM out are operated at 50% duty @2kHz		1		mA
Input Voltage	V _{CC}		4.5	5	5.5	V
Operating Current	I _{CC}	V _{CC} = 5V, All PWM out are operated at 50% duty @2kHz		7		mA
Digital Interface						
Input Logic High Threshold	V _{HI}		2			V
Input Logic Low Threshold	V _{IL}				0.4	V
Output high voltage	V _{OH}	I _{OH} = -1mA	2.4			V
Output low voltage	V _{OL}	I _{OH} = 1mA			0.4	V
LED Current Control						
Current limiter output accuracy error	ε	40mA ≤ I _{OUT} ≤ 80mA @ 100% duty cycle, 175mV ≤ V _{SENSE} ≤ 350mV (R _S = 4.375Ω).		± 0.82	± 0.91	%
See Note 1. (Tested @ Room Temp)		I _{OUT} = 100mA @ 100% duty cycle, V _{SENSE} = 350mV (R _S = 3.5Ω).			± 0.69	%

ELECTRICAL CHARACTERISTICS

The following specifications apply over the operating ambient temperature $-40^{\circ}\text{C} \leq T_{\text{AMB}} \leq 85^{\circ}\text{C}$ except where otherwise noted and the following test conditions: $V_{\text{CC}} = 5.0\text{V}$. Performance must be guaranteed for $0^{\circ}\text{C} \leq T_{\text{J}} \leq 110^{\circ}\text{C}$

Parameter	Symbol	Test Conditions / Comment	Min	Typ	Max	Units
		$I_{\text{OUT}} = 200\text{mA}$ @ 50% duty cycle, $V_{\text{SENSE}} = 350\text{mV}$ ($R_{\text{S}} = 1.75\Omega$).			0.89	%
V_{REF} Range			0		2.5	V
S0-7 Out. Voltage Range			0		357	mV
LED Switching FET $R_{\text{DS-ON}}$		@ 100mA force through LED pin		3.2	5	Ω
Port Switching Output Leakage (I_{LED})		While port is off and $V_{\text{DRAIN}} = 60\text{V}$ $T_{\text{amb}} = 25^{\circ}\text{C}$		0.1	1	μA
Port rise (sense pin) or fall time (drain) – PWM.		@ $V_{\text{MAIN}} = 5\text{V}$, $R_{\text{LOAD}} = 60\Omega$, $C_{\text{LOAD}} = 33\text{pF}$	0.45	0.95	1.7	μS
Port delay - between PWM control and sense voltage increase.		@ 100 mA	0.25	0.6	1.15	μS
		@ 50 mA	0.4	0.95	2	μS
		@ 10 mA	1.2	3.2	7	μS
Protections						
Over Temp. Detection (This parameter is GBD.)	Max Temp	Per Port Thermal Sensor, located @ the driver main LED switching FET – shut off the port if junction Temperature exceed MAX TEMP level	150	180	210	$^{\circ}\text{C}$
Drain Over-voltage Protection Threshold		Shuts a channel off if the Vd voltage exceeds this level.	6.0	6.4	6.8	V
ESD – HBM*		At all pins - JEDEC JESD22-A114	± 2			kV
ESD - MM		At all pins - JEDEC JESD22-A115-A	± 200			V
ESD - CDM		At all pins - JEDEC JESD22-C101C	± 500			V
Test Mode						
Threshold Voltage at V_{REF}			3.4			V

Note 1: Current accuracy error is calculated according to the below formulas:

$$\varepsilon[\%] = 100 \frac{I_{\text{OUT}} - I_{\text{SET}}}{I_{\text{SET}}}$$

Where the adjusted current is:

$$I_{\text{SET}} = \frac{V_{\text{REF}}}{2.5V} I_{\text{MAX}}$$

$$I_{\text{MAX}} = \frac{2.5V}{7R_{\text{TOTAL}}}$$

$R_{\text{TOTAL}} = R_{\text{S}} + R_{\text{IC}} + R_{\text{PCB}}$ I_{OUT} is the observed port current, I_{MAX} is the maximum LED current, R_{S} is the sense resistance, R_{IC} (typically $85\text{m}\Omega$) accounts for the internal resistance at the sense pin and R_{PCB} (typically $15\text{m}\Omega$) represents a parasitic resistance that depends on PCB implementation.

FUNCTIONAL PIN DESCRIPTION

Name	Pin #	Description
PWM0-7	1-8	Logic Input Signals. Per Port ON/OFF Control When PWM is asserted "0" – LED String is disabled (OFF)
S0-7	31, 30, 27, 26, 15, 14, 11, 10	Current sense pins. These pins are connected to external resistor. The signal from this pin is fed to the LED current regulation amplifier input to maintain the required LED current set by the current reference voltage.
VD0-7	32, 29, 28, 25, 16, 13, 12, 9	Output pins to LED string load. These high voltage output are switched ON/OFF according to the PWM frequency and duty cycle control (PWM input signals). LED Sink Current is Pre-Set by VREF pin
PSEL_IN	24	Serial data input pin. The data from PSEL_IN is clocked into a shift register at the rising edge of the PSEL_CLK. This Serial Data is used to SELECT one VD and one of the Thermal Sensing signals – out to the VDMEAS and THERM_OUT pins.
PSEL_OUT	17	Serial data output pin. The data from the internal shift register is clocked OUT at the rising edge of the PSEL_CLK. This Serial PSEL_OUT - is used to be cascaded into the next LX23108AL Driver – to continue the SELECT functions as described before (VD and Thermal Sensing signals). Through this mechanism – up to 32 Ports can be controlled for VD and Thermal Sense Monitoring.
PSEL_CLK	18	Clock signal for the DIN / DOUT operation. One clock shifts the data by one bit.
VDMEAS	22	Open Drain Output Signal. Port Drain Voltage is multiplexed into this pin, when selected by the internal shift register.
THERM_OUT	23	Open Drain Output Signal. Port Thermal Sensors are latched and multiplexed into this pin, when selected by the internal shift register.
VREF	20	Analog Input signal. This DV voltage, is driven by the LX24132, LX24132A or the LX24232 LED Controller, and used to set all LED current levels.
VCC	19	Supply voltage for the internal circuit. A low ESR bypass capacitor not less than 1uF should be placed as close as possible to this pin with low impedance traces to GND
VIO	21	3.3V VIO Supply voltage pin. This voltage is typically used for the I/Os that are communicated with LX24132, LX24132A or a LX24232 LED Controller.

Package Information

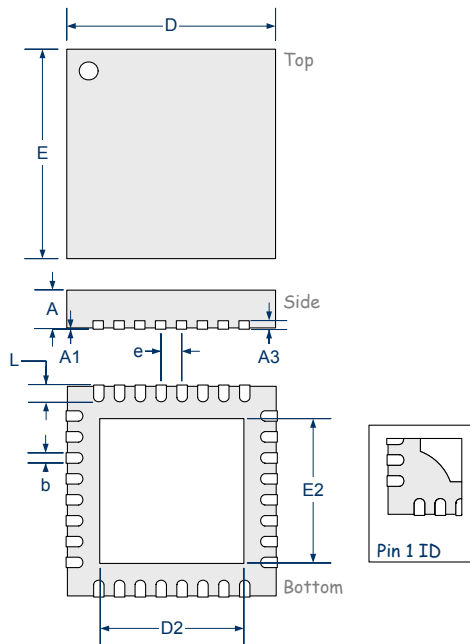
LQ
32-Pin 5x5 mm QFN

DIM	MILLIMETERS		INCHES	
	MIN	MAX	MIN	MAX
A	0.80	1.00	0.031	0.039
A1	0	0.05	0	0.002
A3	0.20 REF		0.008 REF	
b	0.18	0.30	0.007	0.012
D	5.00 BSC		0.197 BSC	
D2	3.30	3.60	0.130	0.142
E	5.00 BSC		0.197 BSC	
E2	3.30	3.60	0.130	0.142
e	0.50 BSC		0.02 BSC	
L	0.30	0.50	0.012	0.020

Note:

Dimensions do not include protrusions; these do not exceed 0.155 mm (.006") on any side. Lead dimension shall not include solder coverage.

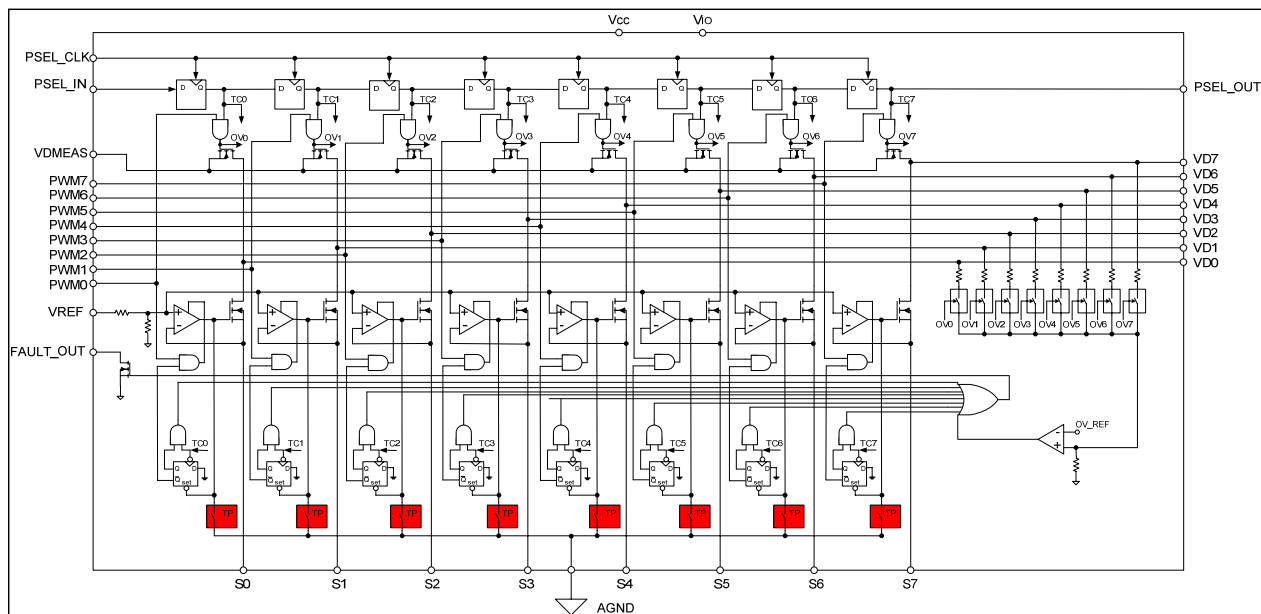
Figure 1: LX23108ALILQ Block Diagram

Functional Description

The following sections provide detailed information about the chip, its functions and applications.

LX23108ALILQ Block Diagram

The LX23108ALILQ has eight current limiters controlled by a dedicated reference voltage and by eight independent PWM control signals (received from the LX24132ILQ). The LX23108ALILQ is designed to operate with current scaling external sense resistors connected to its S0 - S7 pins (refer to Figure 1).

Each current limiter employs three components;

- Operational amplifier
- MOSFET
- External sense resistor

These components are utilized to regulate the LED string current to achieve the desired value.

Channels drain voltage measurements are performed at each string's "on" time, in accordance with the PSEL_CLK and PSEL_IN commands received from the LX24132ILQ 32 Port Display Backlight LED Controller. Each output MOSFET has a thermal sensor which causes it to switch off when its temperature exceeds a predetermined value.

At the same time, the channels output voltages are successively sensed for any possible LED short circuit.

Over-Temperature/LED Short-Circuit Events; Latch and Select Operation Description

Each output MOSFET is thermally protected by a temperature sensor that forces its gate to 'Low' in over-heating scenarios (see TP block in **Error! Reference source not found.**). Hence, the MOSFET is switched off, regardless of the PWM<n> digital command.

The thermal status of each channel is read by the LX24132ILQ sequentially by utilizing a sampling pulse that clocks the thermal flip-flops at the falling edge. If no thermal event occurs, the flip flop's output is maintained 'Low', as well as its associated **AND** gate.

When a thermal event occurs the following takes place:

- The set pin of the thermal flip flop is grounded.
- The Q output is asynchronously forced to a 'High'.
- The output of the AND gate is maintained at 'High' unless a sampling pulse is issued.
- However, while Q is at 'High', the amplifier is disabled by an additional AND gate.

The sequential sampling also activates an over-voltage sensing mechanism formed by OV switches, a resistor divider and a voltage comparator. Such comparator is common to all eight ports and reports LED shorts through a general chip OR gate.

Current Sense Resistor Selection

The value of the external sense resistors is determined as shown below:

$$R_{SENSE} = \frac{V_{REF_MAX}}{7 \cdot I_{MAX}} - R_{IC} - R_{PCB}$$

V_{REF_MAX} is equal to 2.5V; it is the maximum reference voltage.

I_{MAX} is the maximum LED current.

R_{IC} and R_{PCB} are internal IC and PCB resistances, respectively. Typically, R_{IC} is 85 m Ω and R_{PCB} is 15 m Ω .

Power Dissipation Calculation

The power dissipated by the LX23108ALILQ 8-port LED driver is calculated as follows:

$$P_D = V_{CC}I_{CC} + V_{IO}I_{IO} + I_{OUT} \cdot \sum_K V_{DS_K} \cdot D_K$$

I_{OUT} is the output current.

V_{DS_K} and D_K are the drain-source voltage and PWM duty-cycle at channel "K".

Drain Measurements and Select Operation Description

A logic circuitry within the LX23108ALILQ enables the LX24132ILQ to sequentially measure all the array drain voltages and stores the results in internal registers.

The measurements are performed when appropriate commands (determined by the PSEL_IN and PSEL_CLK) are received from the LX24132ILQ at each string's "on" time.

The System Controller uses this information in conjunction with its algorithms to calculate the power dissipation and control the power supply voltage (see Figure 2).

Fault Detection and Protection

The LX23108ALILQ, in conjunction with the LX24132ILQ, has fault detection and protection feature dedicated for an open LED string, short LED and over-temperature (see Figure 2). The open string and short LED faults are detected one by one in such a way that if a fault is detected at a specific stage, it can be shut down individually without affecting the operation of the other LEDs.

The over-temperature protection circuits monitor the die temperature and shut down the relevant channel when temperature reaches a trigger point (See **Error! Reference source not found.** and Figure 2). Such channel returns to normal operation when the temperature drops below the recovery threshold.

Typical Application

As shown in Figure 2, 32 LED strings are supported by a single LX24132ILQ 32 Port Display Backlight LED Controller and four LX23108ALILQs arrays (eight ports each).

Typical applications include:

- LCD display back-lighting
- LED signboards
- LED displays

The System Controller (LED BL FPGA) controls the general modes and sets the parameters for the operation of the LX24132ILQ devices used in the system. The LX24132ILQ sequentially measures the voltages of all LX23108ALILQ 8-port LED driver's channels.

The System Controller performs various calculations based on each LX24132ILQ measurement. Measurements and status information are available in registers within the LX24132ILQ digital block that are accessed through a designated SPI communication bus (see Figure 2).

Therefore, bi-directional information between the system Controller and the LX24132ILQ flows via the SPI communication protocol.

The LX24132ILQ controls the BackLight LED currents by driving the LX23108ALILQ 8-port LED drivers with an accurate voltage reference. Hence, the LX23108ALILQs generates accurate currents for LED strings, up to eight strings per array chip.

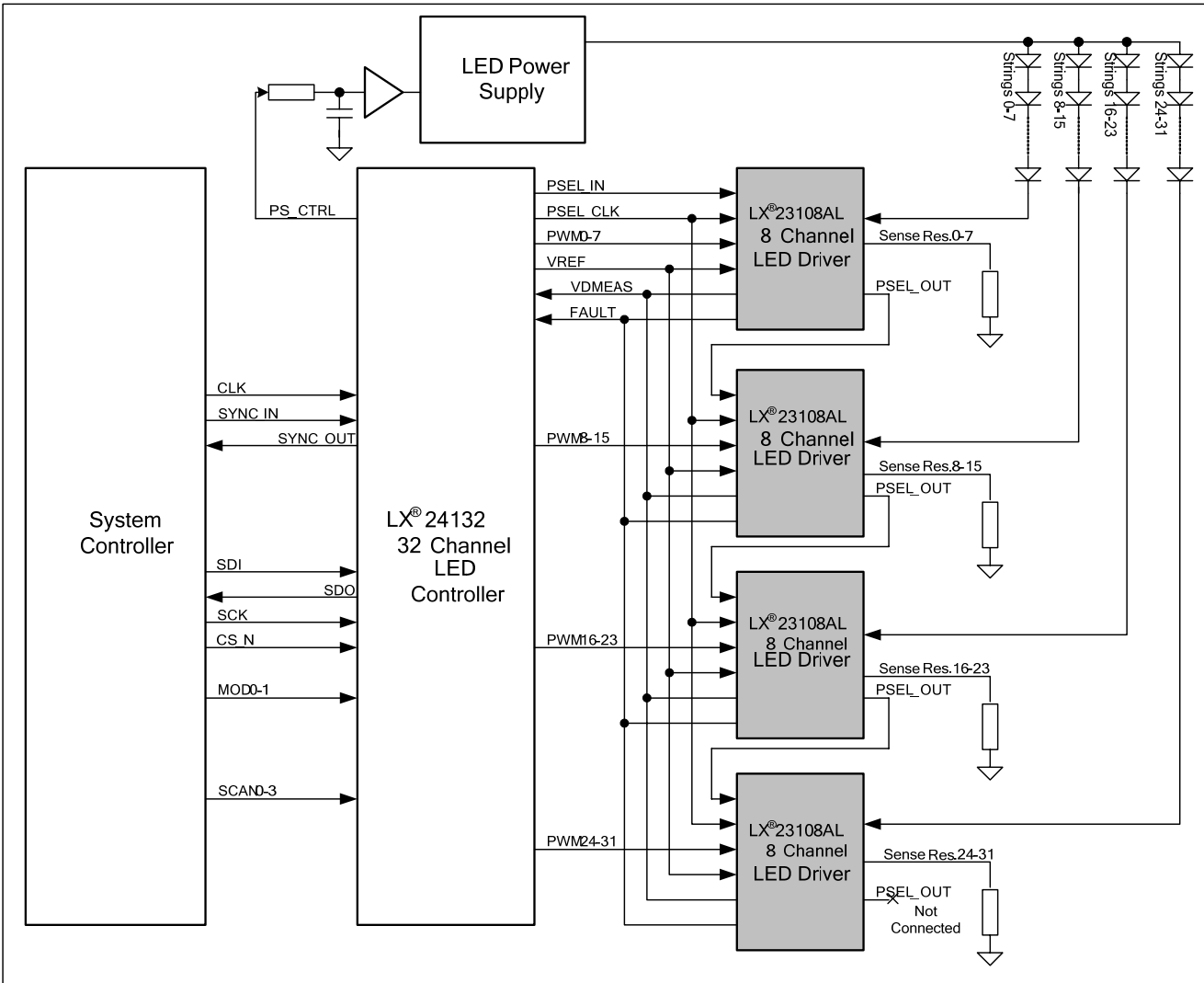

Figure 2: Low Voltage LED Controller and 8 Channel LED Driver



The information contained in the document is PROPRIETARY AND CONFIDENTIAL information of Microsemi and cannot be copied, published, uploaded, posted, transmitted, distributed or disclosed or used without the express duly signed written consent of Microsemi. If the recipient of this document has entered into a disclosure agreement with Microsemi, then the terms of such Agreement will also apply. This document and the information contained herein may not be modified, by any person other than authorized personnel of Microsemi. No license under any patent, copyright, trade secret or other intellectual property right is granted to or conferred upon you by disclosure or delivery of the information, either expressly, by implication, inducement, estoppel or otherwise. Any license under such intellectual property rights must be express and approved by Microsemi in writing signed by an officer of Microsemi.

Microsemi reserves the right to change the configuration, functionality and performance of its products at anytime without any notice. This product has been subject to limited testing and should not be used in conjunction with life-support or other mission-critical equipment or applications. Microsemi assumes no liability whatsoever, and Microsemi disclaims any express or implied warranty, relating to sale and/or use of Microsemi products including liability or warranties relating to fitness for a particular purpose, merchantability, or infringement of any patent, copyright or other intellectual property right. The product is subject to other terms and conditions which can be located on the web at <http://www.microsemi.com/legal/tnc.asp>

Revision History

Revision Level / Date	Para. Affected	Description
1.0 / 25 Jan 2011	-	Initial Release
1.1 / 16 March 2012	-	Update OVP, add symbols to VIO, etc.

© 2011 Microsemi Corp.
All rights reserved.

For support contact: sales_AMSG@microsemi.com

Visit our web site at: www.microsemi.com

Cat. No. DS_LX23108AL