

# SN55111, SN75111 QUADRUPLE LINE DRIVERS WITH COMMON ENABLES

D3000, FEBRUARY 1986—REVISED OCTOBER 1988

- Similar to a Dual Version of the SN55109A/SN75109A Line Driver
- Improved Stability Over Supply Voltage and Temperature Ranges
- Constant-Current Outputs
- High Output Impedance
- High Common-Mode Output Voltage Range (–3 V to 10 V)
- Glitch-Free Power-Up/Power-Down Operation
- TTL Input Compatibility
- Common Enable Circuit

## description

The SN55111 and SN75111 feature four line drivers with a common enable input. When the enable input is high, a constant output current is switched between each pair of output terminals in response to the logic level at that channel's input. When the enable is low, all channel outputs are nonconductive (transistors biased to cutoff). This feature minimizes loading in party-line systems where a large number of drivers share the same line.

The driver outputs have a common-mode voltage range of –3 V to 10 V, allowing common-mode voltages on the line without affecting driver performance.

All outputs should be maintained within the recommended common-mode output voltage range to ensure that the channels do not interact with each other. To minimize power dissipation, all unused inputs should be grounded.

All inputs are diode clamped and are designed to satisfy TTL-system requirements. The inputs are tested at 2 V for high-logic-level input conditions and 0.8 V for low-logic-level input conditions. These tests guarantee 400 mV of noise margin when interfaced with Series 54/74 TTL.

The SN55111 is characterized for operation from –55°C to 125°C. The SN75111 is characterized for operation from 0°C to 70°C.

SN55111 . . . J PACKAGE  
SN75111 . . . D, J, OR N PACKAGE  
(TOP VIEW)

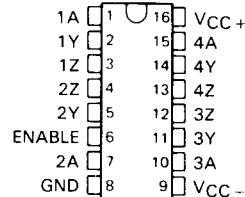

SN55111 . . . FK PACKAGE  
(TOP VIEW)

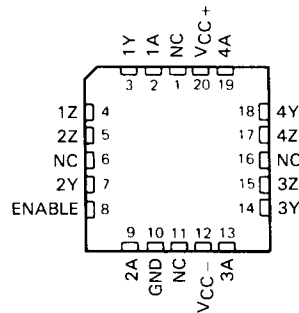

NC—No internal connection

## logic symbol†

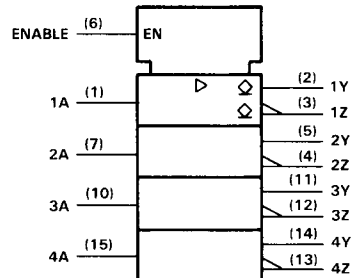

†This symbol is in accordance with ANSI/IEEE Std 91-1984 and IEC Publication 617-12.

Pin numbers shown are for D, J, and N packages.

**SN55111, SN75111**  
**QUADRUPLE LINE DRIVERS WITH COMMON ENABLES**

**FUNCTION TABLE**

LOGIC INPUT	ENABLE INPUT	OUTPUT CURRENT	
		Z	Y
H	H	ON	OFF
L	H	OFF	ON
H	L	OFF	OFF
L	L	OFF	OFF

L = low logic level  
H = high logic level

**logic diagram (positive logic)**

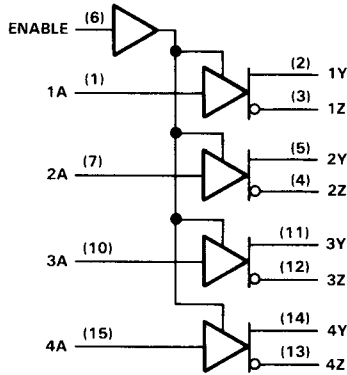

**schematics of inputs and outputs**

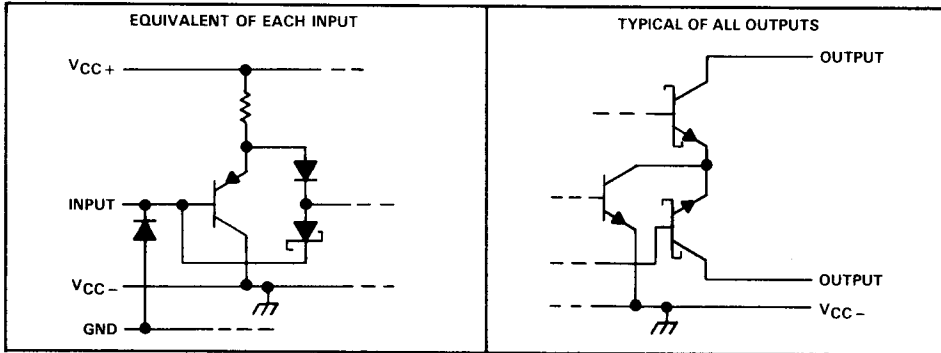

# SN55111, SN75111

## QUADRUPLE LINE DRIVERS WITH COMMON ENABLES

### absolute maximum ratings over operating free-air temperature range (unless otherwise noted)

Supply voltage, $V_{CC+}$ (see Note 1)	7 V
Supply voltage, $V_{CC-}$	-7 V
Input voltage (any input)	5.5 V
Output voltage range (any output)	-5 V to 12 V
Continuous total dissipation	See Dissipation Rating Table
Operating free-air temperature range: SN55111	-55°C to 125°C
SN75111	0°C to 70°C
Storage temperature range	-65°C to 150°C
Case temperature for 60 seconds: FK package	260°C
Lead temperature 1,6 mm (1/16 inch) from case for 10 seconds: D or N package	260°C
Lead temperature 1,6 mm (1/16 inch) from case for 60 seconds: J package	300°C

NOTE 1: All voltage values are with respect to network ground terminal.

**DISSIPATION RATING TABLE**

PACKAGE	$T_A \leq 25^\circ\text{C}$	DERATING FACTOR	$T_A = 70^\circ\text{C}$	$T_A = 85^\circ\text{C}$
	POWER RATING	ABOVE $T_A = 25^\circ\text{C}$	POWER RATING	POWER RATING
D	950 mW	7.6 mW/°C	608 mW	N/A
FK	1375 mW	11.0 mW/°C	880 mW	275 mW
J (SN55111)	1375 mW	11.0 mW/°C	880 mW	275 mW
J (SN75111)	1025 mW	8.2 mW/°C	656 mW	N/A
N	1150 mW	9.2 mW/°C	736 mW	N/A

### recommended operating conditions (see Note 2)

		SN55111			SN75111			UNIT
		MIN	NOM	MAX	MIN	NOM	MAX	
Supply voltage, $V_{CC+}$	$T_A \geq 25^\circ\text{C}$	4.5	5	5.5	4.75	5	5.25	V
	$T_A < 25^\circ\text{C}$	4.75	5	5.5	4.75	5	5.25	
Supply voltage, $V_{CC-}$	$T_A \geq 25^\circ\text{C}$	-4.5	-5	-5.5	-4.75	-5	-5.25	V
	$T_A < 25^\circ\text{C}$	-4.75	-5	-5.5	-4.75	-5	-5.25	
High-level input voltage, $V_{IH}$		2		5.5	2		5.5	V
Low-level input voltage, $V_{IL}$		0		0.8	0		0.8	V
Common-mode output voltage range	$V_{OCR+}$	0		10	0		10	V
	$V_{OCR-}$	0		-3	0		-3	
Operating free-air temperature, $T_A$		-55		125	0		70	°C

NOTE 2: All unused outputs should be grounded.

# SN55111, SN75111

## QUADRUPLE LINE DRIVERS WITH COMMON ENABLES

electrical characteristics over recommended operating free-air temperature range,  $V_{CC+} = \text{MAX}$ ,  $V_{CC-} = \text{MAX}$  (unless otherwise noted)

PARAMETER	TEST CONDITIONS†	MIN	TYP‡	MAX	UNIT
$V_{IK}$ Input clamp voltage	$I_I = -12 \text{ mA}$	-0.9	-1.5		V
$I_{O(on)}$ On-state output current	$V_{CC+} = \text{MAX}$ , $V_{CC-} = \text{MAX}$		5.5	7	mA
	$V_{CC+} = \text{MIN}$ , $V_{CC-} = \text{MIN}$	3.5	5.5		
$I_{O(off)}$ Off-state output current	$V_{CC+} = \text{MIN}$ , $V_{CC-} = \text{MIN}$ , $V_O = 10\text{V}$			100	$\mu\text{A}$
$I_{IH}$ High-level input current	$V_I = 2.4 \text{ V}$			40	$\mu\text{A}$
	$V_I = V_{CC+} \text{ MAX}$			1	mA
$I_{IL}$ Low-level input current	$V_I = 0.4 \text{ V}$			-1.6	mA
	A inputs at 0.4 V	Enable at 2 V	28	40	mA
$I_{CC+}$ Supply current from $V_{CC+}$	A inputs at 0.4 V	Enable at 0.4 V	27	40	
	$I_{CC-}$ Supply current from $V_{CC-}$	A inputs at 0.4 V	Enable at 2 V	-43	-55
A inputs at 0.4 V		Enable at 0.4 V	-25	-35	

†For conditions shown as MIN or MAX, use the appropriate value specified under recommended operating conditions.

‡All typical values are at  $V_{CC+} = 5 \text{ V}$ ,  $V_{CC-} = -5 \text{ V}$ , and  $T_A = 25^\circ\text{C}$ .

switching characteristics,  $V_{CC+} = 5 \text{ V}$ ,  $V_{CC-} = -5 \text{ V}$ ,  $R_L = 50 \Omega$ ,  $C_L = 40 \text{ pF}$ ,  $T_A = 25^\circ\text{C}$

PARAMETER	FROM (INPUT)	TO (OUTPUT)	TEST CONDITIONS	MIN	TYP	MAX	UNIT
$t_{PLH}$ Propagation delay time, low-to-high-level output	A	Y or Z	See Figure 1		9	15	ns
$t_{PHL}$ Propagation delay time, high-to-low-level output	A	Y or Z			7	15	ns
$t_{PLH}$ Propagation delay time, low-to-high-level output	Enable	Y or Z			14	25	ns
$t_{PHL}$ Propagation delay time, high-to-low-level output	Enable	Y or Z			15	25	ns



PARAMETER MEASUREMENT INFORMATION

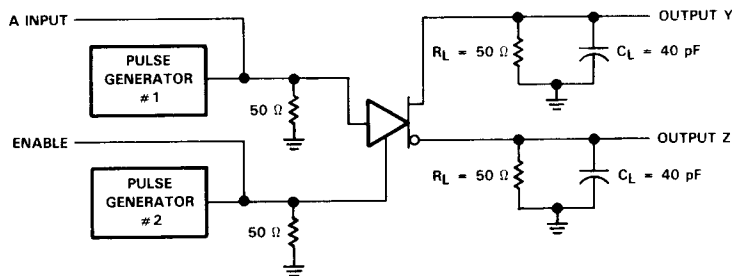

TEST CIRCUIT

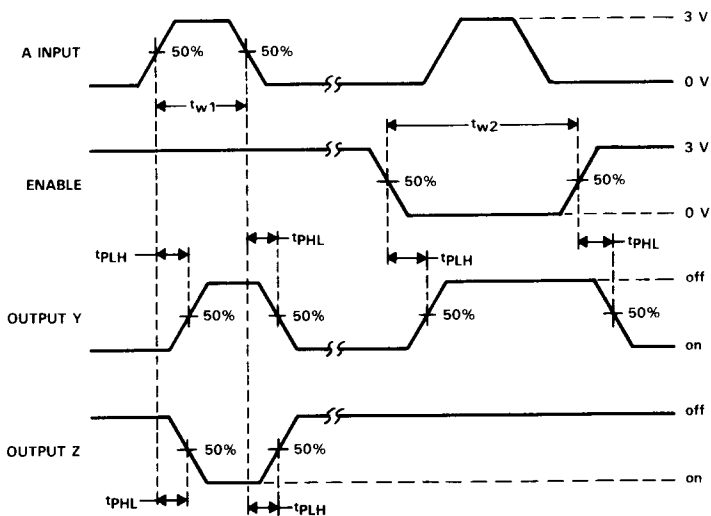

VOLTAGE WAVEFORMS

- NOTES: A. The pulse generators have the following characteristics:  $Z_0 \approx 50 \Omega$ ,  $t_r = t_f = 10 \pm 5 \text{ ns}$ ,  $t_{w1} \leq 200 \text{ ns}$ ,  $\text{PRR} \leq 1 \text{ MHz}$ ,  $t_{w2} \leq 1 \mu\text{s}$ ,  $\text{PRR} \leq 500 \text{ kHz}$ .  
 B.  $C_L$  includes probe and jig capacitance.

FIGURE 1. PROPAGATION DELAY TIMES