

1-of-8 Decoder

Features

- Function, pinout, and drive compatible with FCT and F logic
- FCT-C speed at 5.0 ns max. (Com'l)
FCT-A speed at 5.8 ns max. (Com'l)
- Reduced V_{OH} (typically = 3.3V) versions of equivalent FCT functions
- Edge-rate control circuitry for significantly improved noise characteristics
- Power-off disable feature
- ESD > 2000V

- Matched rise and fall times
- Fully compatible with TTL input and output logic levels
- Sink current 64 mA (Com'l),
 32 mA (Mil)
- Source current 32 mA (Com'l),
 12 mA (Mil)
- Dual 1-of-8 decoder with enables

Functional Description

The FCT138T is a 1-of-8 decoder. The FCT138T accepts three binary weighted inputs (A_0 , A_1 , A_2) and, when enabled, provides eight mutually exclusive active

LOW outputs ($\bar{O}_0 - \bar{O}_7$). The FCT138T features three enable inputs, two active LOW (\bar{E}_1 , \bar{E}_2) and one active HIGH (E_3).

All inputs will be HIGH unless \bar{E}_1 and \bar{E}_2 are LOW and E_3 is HIGH. This multiple enable function allows easy parallel expansion of the device to a 1-of-32 (5 lines to 32 lines) decoder with just four FCT138T devices and one inverter.

The outputs are designed with a power-off disable feature to allow for live insertion of boards.

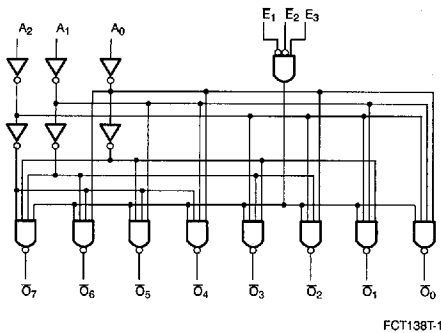
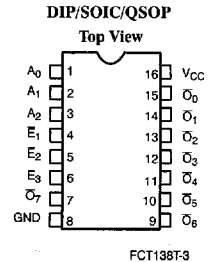
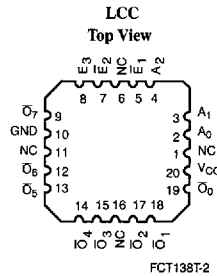
Logic Block Diagram

Pin Configurations

Pin Description

Name	Description
A	Address Inputs
$\bar{E}_1 - \bar{E}_2$	Enable Inputs (Active LOW)
E_3	Enable Input (Active HIGH)
\bar{O}	Outputs

Function Table^[1]

Inputs						Outputs							
\bar{E}_1	\bar{E}_2	E_3	A_0	A_1	A_2	\bar{O}_0	\bar{O}_1	\bar{O}_2	\bar{O}_3	O_4	\bar{O}_5	\bar{O}_6	\bar{O}_7
H	X	X	X	X	X	H	H	H	H	H	H	H	H
X	H	X	X	X	X	H	H	H	H	H	H	H	H
X	X	L	X	X	X	H	H	H	H	H	H	H	H
L	L	H	L	L	L	L	H	H	H	H	H	H	H
L	L	H	H	L	L	L	L	H	H	H	H	H	H
L	L	H	L	L	L	L	H	H	L	H	H	H	H
L	L	H	H	H	L	L	H	H	L	L	H	H	H
L	L	H	L	L	L	L	H	H	L	L	H	H	H
L	L	H	H	H	H	H	H	H	H	L	H	H	H
L	L	H	L	L	L	H	H	H	H	H	H	L	L

Maximum Ratings^[2,3]

(Above which the useful life may be impaired. For user guidelines, not tested.)

Storage Temperature -65°C to $+150^{\circ}\text{C}$
 Ambient Temperature with
 Power Applied -65°C to $+135^{\circ}\text{C}$
 Supply Voltage to Ground Potential -0.5V to $+7.0\text{V}$
 DC Input Voltage -0.5V to $+7.0\text{V}$
 DC Output Voltage -0.5V to $+7.0\text{V}$
 DC Output Current (Maximum Sink Current/Pin) 120 mA
 Power Dissipation 0.5W

Static Discharge Voltage $>2001\text{V}$
 (per MIL-STD-883, Method 3015)

Operating Range

Range	Range	Ambient Temperature	V_{CC}
Commercial	CT	0°C to $+70^{\circ}\text{C}$	$5\text{V} \pm 5\%$
Commercial	T, AT	-40°C to $+85^{\circ}\text{C}$	$5\text{V} \pm 5\%$
Military ^[4]	All	-55°C to $+125^{\circ}\text{C}$	$5\text{V} \pm 10\%$

Electrical Characteristics Over the Operating Range

Parameter	Description	Test Conditions		Min.	Typ. ^[5]	Max.	Unit
V_{OH}	Output HIGH Voltage	$V_{CC}=\text{Min.}, I_{OH}=-32\text{ mA}$	Com'l	2.0			V
		$V_{CC}=\text{Min.}, I_{OH}=-15\text{ mA}$	Com'l	2.4	3.3		V
		$V_{CC}=\text{Min.}, I_{OH}=-12\text{ mA}$	Mil	2.4	3.3		V
V_{OL}	Output LOW Voltage	$V_{CC}=\text{Min.}, I_{OL}=64\text{ mA}$	Com'l		0.3	0.55	V
		$V_{CC}=\text{Min.}, I_{OL}=32\text{ mA}$	Mil		0.3	0.55	V
V_{IH}	Input HIGH Voltage			2.0			V
V_{IL}	Input LOW Voltage					0.8	V
V_H	Hysteresis ^[6]	All inputs			0.2		V
V_{IK}	Input Clamp Diode Voltage	$V_{CC}=\text{Min.}, I_{IN}=-18\text{ mA}$			-0.7	-1.2	V
I_I	Input HIGH Current	$V_{CC}=\text{Max.}, V_{IN}=V_{CC}$				5	μA
I_{IH}	Input HIGH Current	$V_{CC}=\text{Max.}, V_{IN}=2.7\text{V}$				± 1	μA
I_{IL}	Input LOW Current	$V_{CC}=\text{Max.}, V_{IN}=0.5\text{V}$				± 1	μA
I_{OS}	Output Short Circuit Current ^[7]	$V_{CC}=\text{Max.}, V_{OUT}=0.0\text{V}$		-60	-120	-225	mA
I_{OFF}	Power-Off Disable	$V_{CC}=0\text{V}, V_{OUT}=4.5\text{V}$				± 1	μA

Notes:

- H = HIGH Voltage Level. L = LOW Voltage Level. X = Don't Care.
- Unless otherwise noted, these limits are over the operating free-air temperature range.
- Unused inputs must always be connected to an appropriate logic voltage level, preferably either V_{CC} or ground.
- T_A is the "instant on" case temperature.
- Typical values are at $V_{CC}=5.0\text{V}, T_A=+25^{\circ}\text{C}$ ambient.
- This parameter is guaranteed but not tested.
- Not more than one output should be shorted at a time. Duration of short should not exceed one second. The use of high-speed test apparatus and/or sample and hold techniques are preferable in order to minimize internal chip heating and more accurately reflect operational values. Otherwise prolonged shorting of a high output may raise the chip temperature well above normal and thereby cause invalid readings in other parametric tests. In any sequence of parameter tests, I_{OS} tests should be performed last.

Capacitance^[6]

Parameter	Description	Typ. ^[5]	Max.	Unit
C _{IN}	Input Capacitance	5	10	pF
C _{OUT}	Output Capacitance	9	12	pF

Power Supply Characteristics

Parameter	Description	Test Conditions	Typ. ^[5]	Max.	Unit
I _{CC}	Quiescent Power Supply Current	V _{CC} =Max., V _{IN} ≤0.2V, V _{IN} ≥V _{CC} -0.2V	0.1	0.2	mA
ΔI _{CC}	Quiescent Power Supply Current (TTL inputs)	V _{CC} =Max., V _{IN} =3.4V ^[8] f ₁ =0, Outputs Open	0.5	2.0	mA
I _{CCD}	Dynamic Power Supply Current ^[9]	V _{CC} =Max., One Input Toggling, 50% Duty Cycle, Outputs Open, V _{IN} ≤0.2V or V _{IN} ≥V _{CC} -0.2V	0.06	0.12	mA/ MHz
I _C	Total Power Supply Current ^[10]	V _{CC} =Max., f ₁ =10 MHz, 50% Duty Cycle, Outputs Open, Toggle E ₁ , E ₂ , or E ₃ , One Output Toggling, V _{IN} ≤0.2V or V _{IN} ≥V _{CC} -0.2V	0.7	1.4	mA
		V _{CC} =Max., f ₁ =10 MHz, 50% Duty Cycle, Outputs Open, Toggle E ₁ , E ₂ , or E ₃ , One Output Toggling, V _{IN} =3.4V or V _{IN} =GND	1.0	2.4	mA

Notes:

8. Per TTL driven input (V_{IN}=3.4V); all other inputs at V_{CC} or GND.

9. This parameter is not directly testable, but is derived for use in Total Power Supply calculations.

10. I_C = I_{QUIESCENT} + I_{INPUTS} + I_{DYNAMIC}

I_C = I_{CC} + ΔI_{CCD}D_HN_T + I_{CCD}(f₀/2 + f₁N₁)

I_{CC} = Quiescent Current with CMOS input levels

ΔI_{CC} = Power Supply Current for a TTL HIGH input (V_{IN}=3.4V)

D_H = Duty Cycle for TTL inputs HIGH

N_T = Number of TTL inputs at D_H

I_{CCD} = Dynamic Current caused by an input transition pair (HLH or LHL)

f₀ = Clock frequency for registered devices, otherwise zero

f₁ = Input signal frequency

N₁ = Number of inputs changing at f₁

All currents are in milliamps and all frequencies are in megahertz.

Switching Characteristics Over the Operating Range

Parameter	Description	FCT138T				FCT138AT				Unit	Fig. No. ^[12]
		Military		Commercial		Military		Commercial			
		Min. ^[11]	Max.	Min. ^[11]	Max.	Min. ^[11]	Max.	Min. ^[11]	Max.		
t _{PLH} t _{PHL}	Propagation Delay A to \bar{O}	1.5	12.0	1.5	9.0	1.5	7.8	1.5	5.8	ns	1, 2
t _{PLH} t _{PHL}	Propagation Delay \bar{E}_1 or \bar{E}_2 to \bar{O}	1.5	12.5	1.5	9.0	1.5	8.0	1.5	5.9	ns	1, 5
t _{PLH} t _{PHL}	Propagation Delay E_3 to \bar{O}	1.5	12.5	1.5	9.0	1.5	8.0	1.5	5.9	ns	1, 5

Parameter	Description	FCT138CT				Unit	Fig. No. ^[12]
		Military		Commercial			
		Min. ^[11]	Max.	Min. ^[11]	Max.		
t _{PLH} t _{PHL}	Propagation Delay A to \bar{O}	1.5	6.0	1.5	5.0	ns	1, 2
t _{PLH} t _{PHL}	Propagation Delay \bar{E}_1 or \bar{E}_2 to \bar{O}	1.5	6.1	1.5	5.0	ns	1, 5
t _{PLH} t _{PHL}	Propagation Delay E_3 to \bar{O}	1.5	6.1	1.5	5.0	ns	1, 5

Ordering Information

Speed (ns)	Ordering Code	Package Name	Package Type	Operating Range
5.0	CY74FCT138CTPC	P1	16-Lead (300-Mil) Molded DIP	Commercial
	CY74FCT138CTQC	Q1	16-Lead (150-Mil) QSOP	
	CY74FCT138CTSOC	S1	16-Lead (300-Mil) Molded SOIC	
5.8	CY74FCT138ATPC	P1	16-Lead (300-Mil) Molded DIP	Commercial
	CY74FCT138ATQC	Q1	16-Lead (150-Mil) QSOP	
	CY74FCT138ATSOC	S1	16-Lead (300-Mil) Molded SOIC	
6.0	CY54FCT138CTDMB	D2	16-Lead (300-Mil) CerDIP	Military
	CY54FCT138CTLMB	L61	20-Pin Square Leadless Chip Carrier	
7.8	CY54FCT138ATDMB	D2	16-Lead (300-Mil) CerDIP	Military
	CY54FCT138ATLMB	L61	20-Pin Square Leadless Chip Carrier	
9.0	CY74FCT138TPC	P1	16-Lead (300-Mil) Molded DIP	Commercial
	CY74FCT138TQC	Q1	16-Lead (150-Mil) QSOP	
	CY74FCT138TSOC	S1	16-Lead (300-Mil) Molded SOIC	
12.0	CY54FCT138TDMB	D2	16-Lead (300-Mil) CerDIP	Military
	CY54FCT138TLMB	L61	20-Pin Square Leadless Chip Carrier	

Notes:

11. Minimum limits are guaranteed but not tested on Propagation Delays. 12. See "Parameter Measurement Information" in the General Information Section.

Document #: 38-00297-A