

Features

- ESD Protect for 5 Lines with Unidirectional.
- Provide ESD protection for each line to IEC 61000-4-2 (ESD) $\pm 16\text{kV}$ (air), $\pm 10\text{kV}$ (contact)
- IEC 61000-4-4 (EFT) 20A (5/50ns)
- IEC 61000-4-5 (Lightning) 5A (8/20 μs)
- Below 5V operating voltage
- Fast turn-on and Low clamping voltage
- Array of surge rated equivalent TVS diodes
- Small package saves board space
- Solid-state silicon-avalanche and active circuit triggering technology

Applications

- Cellular Handsets and Accessories
- Small Panel Modules
- PDA's
- Portable Devices
- Digital Cameras
- Touch Panels
- Notebooks and Handhelds
- MP3 Players
- Peripherals

Description

AZ2015-05C is a design which includes surge rated clamping cell arrays to protect the power lines or data/control lines in an electronic systems. The AZ2015-05C has been specifically designed to protect sensitive components which are connected to power and control lines from over-voltage caused by Electrostatic Discharging (ESD), Electrical Fast Transients (EFT), and Lightning.

AZ2015-05C is a unique design which includes proprietary clamping cells in a single package. During transient conditions, the proprietary clamping cells prevent over-voltage on the power lines or control lines, protecting any downstream components.

AZ2015-05C may be used to meet the ESD immunity requirements of IEC 61000-4-2, Level 4 ($\pm 15\text{kV}$ air, $\pm 8\text{kV}$ contact discharge).

Circuit Diagram

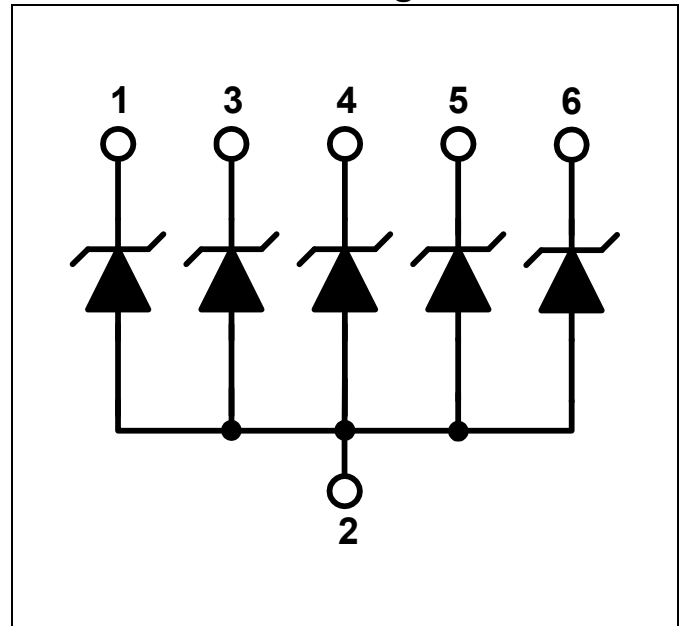

Pin Configuration

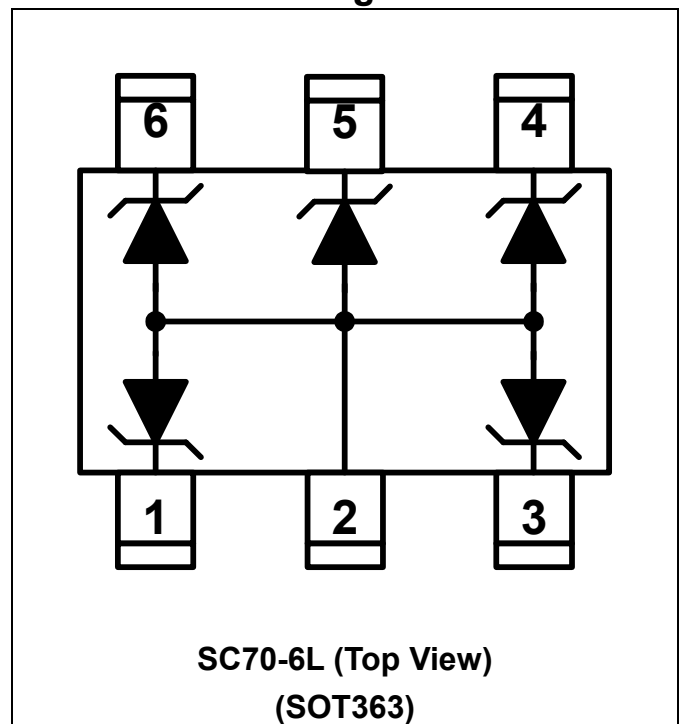

SPECIFICATIONS

ABSOLUTE MAXIMUM RATINGS			
PARAMETER	PARAMETER	RATING	UNITS
Peak Pulse Current (tp =8/20us)	I _{PP}	5A	A
Operating Supply Voltage (pin-1,-2 to pin-3)	V _{DC}	6	V
pin-1,-3, -4, -5, -6 to pin-2 ESD per IEC 61000-4-2 (Air)	V _{ESD1}	16	kV
pin-1,-3, -4, -5, -6 to pin-2 ESD per IEC 61000-4-2 (Contact)		10	
Lead Soldering Temperature	T _{SOL}	260 (10 sec.)	°C
Operating Temperature	T _{OP}	-55 to +85	°C
Storage Temperature	T _{STO}	-55 to +150	°C

ELECTRICAL CHARACTERISTICS						
PARAMETER	SYMBOL	CONDITIONS	MINI	TYP	MAX	UNITS
Reverse Stand-Off Voltage	V _{RMM}	pin-1,-3, -4, -5, -6 to pin-2, T=25 °C.			5	V
Reverse Leakage Current	I _{Leak}	V _{RMM} = 5V, T=25 °C, pin-1,-3, -4, -5, -6 to pin-2.			2.5	μA
Reverse Breakdown Voltage	V _{BV}	I _{BV} = 1mA, T=25 °C, pin-1,-3, -4, -5, -6 to pin-2	6		9	V
Forward Voltage	V _F	I _F = 15mA, T=25 °C, pin-2 to pin-1,-3, -4, -5, -6	0.6	0.8	1	V
Surge Clamping Voltage	V _{CL-surge}	I _{PP} =5A, tp=8/20us, T=25 °C, pin-1,-3, -4, -5, -6 to pin-2.		8.5		V
ESD Clamping Voltage	V _{clamp}	IEC 61000-4-2 +6kV, T=25 °C, Contact mode, pin-1,-3, -4, -5, -6 to pin-2.		10		V
ESD Dynamic Turn-on Resistance	R _{dynamic}	IEC 61000-4-2 0~+6kV, T=25 °C, Contact mode, pin-1,-3, -4, -5, -6 to pin-2.		0.3		Ω
Channel Input Capacitance	C _{IN}	V _R = 0V, f = 1MHz, T=25 °C, pin-1,-3, -4, -5, -6 to pin-2.		7	9	pF

Typical Characteristics

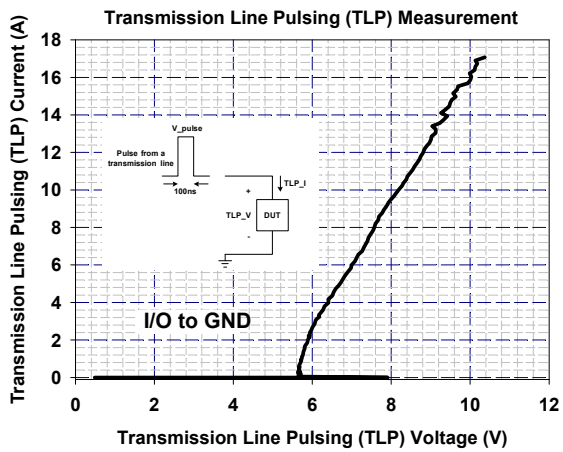
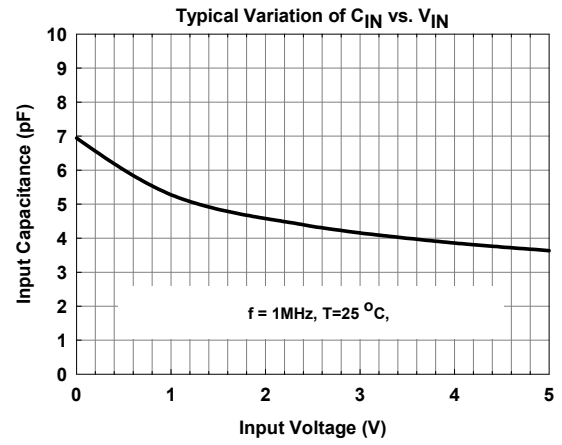
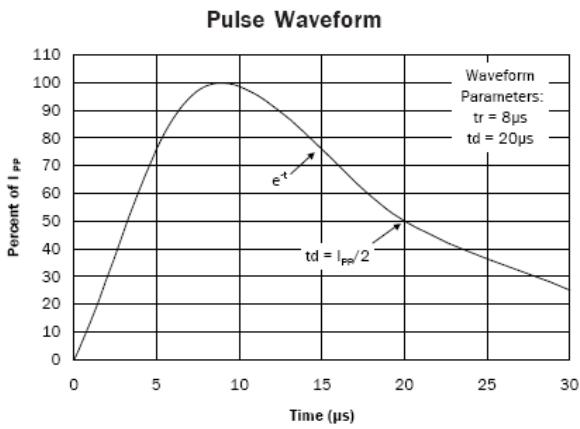

Applications Information

The AZ2015-05C is designed to protect five lines against System ESD/EFT/Lightning pulses by clamping them to an acceptable reference.

The usage of the AZ2015-05C is shown in Fig. 1. Protected lines, such as data lines, control lines, or power lines, are connected at pin 1, 3, 4, 5 and 6. The pin 2 should be connected directly to a ground plane on the board. All path lengths connected to the pins of AZ2015-05C should be kept as short as possible to minimize parasitic inductance in the board traces.

In order to obtain enough suppression of ESD induced transient, good circuit board is critical. Thus, the following guidelines are recommended:

- Minimize the path length between the protected lines and the AZ2015-05C.
- Place the AZ2015-05C near the input terminals or connectors to restrict transient coupling.
- The ESD current return path to ground should be kept as short as possible.
- Use ground planes whenever possible.
- NEVER route critical signals near board edges and near the lines which the ESD transient easily injects to.

Fig. 2 shows an example of PCB layout with the AZ2015-05C.

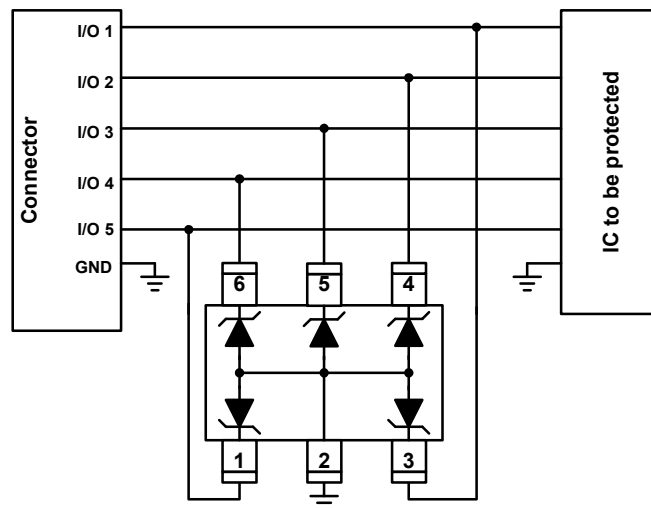

Fig. 1

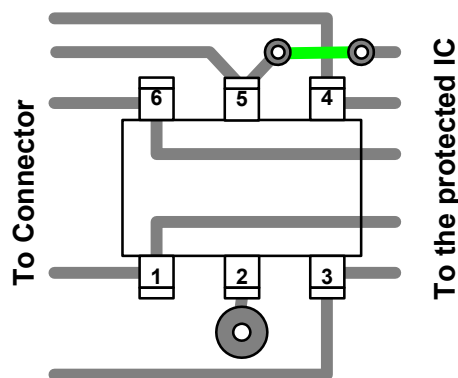
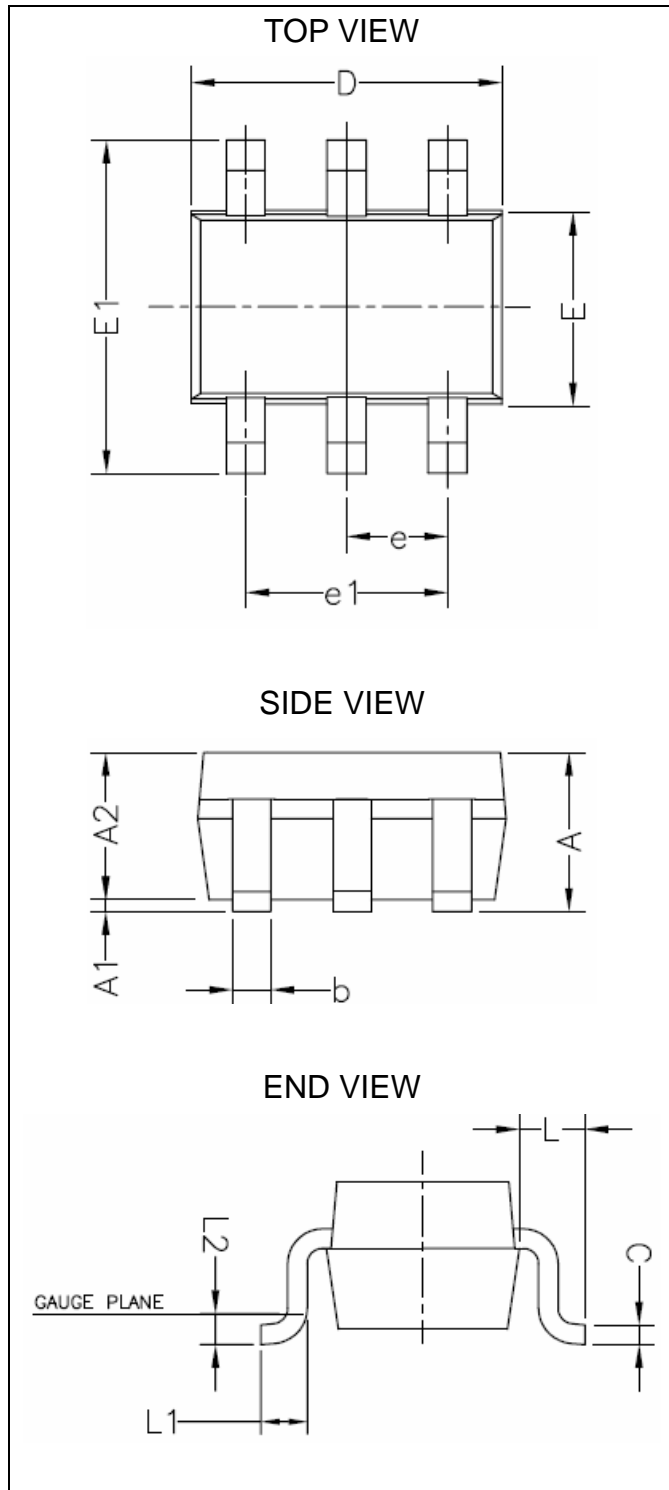

Fig. 2

Mechanical Details

SC70-6L

PACKAGE DIAGRAMS



PACKAGE DIMENSIONS

Symbol	Millimeters		Inches	
	MIN.	MAX.	MIN.	MAX.
A	0.90	1.10	.036	.044
A1	0.025	0.10	.001	.004
A2	0.875	1.00	.035	.040
b	0.20	0.40	.008	.016
C	0.10	0.15	.004	.006
D	1.90	2.10	.076	.084
E	1.15	1.35	.046	.054
E1	2.00	2.20	.080	.088
e	0.65 BSC.		.026 BSC.	
e1	1.30 BSC.		.052 BSC.	
L	0.425 REF.		.017 REF.	
L1	0.300 REF.		.012 REF.	
L2	0.200 REF.		.007 REF.	

Note:
1. All dimensions are in millimeters, and the dimensions in inches are for reference only.
2. 1mm=40mils=0.04inches

LAND LAYOUT

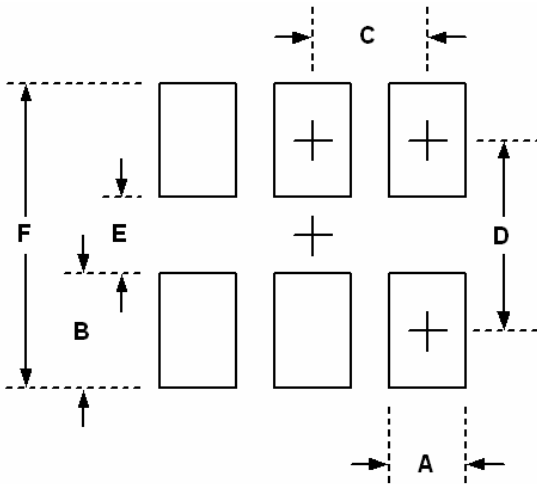

Dimensions		
Index	Millimeter	Inches
A	0.40	0.016
B	0.85	0.033
C	0.65	0.026
D	1.85	0.073
E	1.00	0.039
F	2.70	0.106

Notes:

This LAND LAYOUT is for reference purposes only. Please consult your manufacturing partners to ensure your company's PCB design guidelines are met.

MARKING CODE

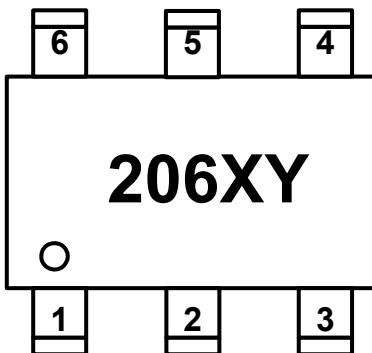

Part Number	Marking Code
AZ2015-05C	206XY
Engineering Sample	P1YD

206 = Device Code
X = Date Code
Y = Control Code

Revision History

Revision	Modification Description
Revision 2007/06/26	Preliminary Release.
Revision 2007/07/10	Original Formal Release.