



# FAST CMOS 18-BIT REGISTERED TRANSCEIVER

## IDT54/74FCT162500/AT/CT/ET

### FEATURES:

- 0.5 MICRON CMOS Technology
- High-speed, low-power CMOS replacement for ABT functions
- Typical  $t_{sk(o)}$  (Output Skew) < 250ps
- Low input and output leakage  $\leq 1\mu A$  (max.)
- ESD > 2000V per MIL-STD-883, Method 3015; > 200V using machine model (C = 200pF, R = 0)
- 25 mil pitch SSOP, 19.6 mil pitch TSSOP, 15.7 mil pitch TVSOP and 25 mil pitch CERPACK packages
- Extended commercial range of -40°C to +85°C
- $V_{CC} = 5V \pm 10\%$
- Balanced Output Drivers:
  - $\pm 24mA$  (commercial)
  - $\pm 16mA$  (military)
- Reduced system switching noise
- Typical VOLP (Output Ground Bounce) < 0.6V at  $V_{CC} = 5V$ ,  $T_A = 25^\circ C$

### DESCRIPTION:

The FCT162500AT/CT/ET 18-bit registered transceivers are built using advanced dual metal CMOS technology. These high-speed, low-power 18-bit registered bus transceivers combine D-type latches and D-type flip-flops to allow data flow in transparent, latched and clocked modes. Data flow in each direction is controlled by output-enable (OEAB and OEBA), latch enable (LEAB and LEBA) and clock (CLKAB and CLKBA) inputs. For A-to-B data flow, the device operates in transparent mode when LEAB is high. When LEAB is low, the A data is latched if CLKAB is held at a high or low logic level. If LEAB is low, the A bus data is stored in the latch/flip-flop on the high-to-low transition of CLKAB. OEAB performs the output enable function on the B port. Data flow from B port to A port is similar but uses OEBA, LEBA and CLKBA. Flow-through organization of signal pins simplifies layout. All inputs are designed with hysteresis for improved noise margin.

The FCT162500AT/CT/ET have balanced output drive with current limiting resistors. This offers low ground bounce, minimal undershoot, and controlled output fall times—reducing the need for external series terminating resistors. The FCT162500AT/CT/ET are plug-in replacements for the FCT16500AT/CT/ET and ABT16500 for on-board bus interface applications.

### FUNCTIONAL BLOCK DIAGRAM

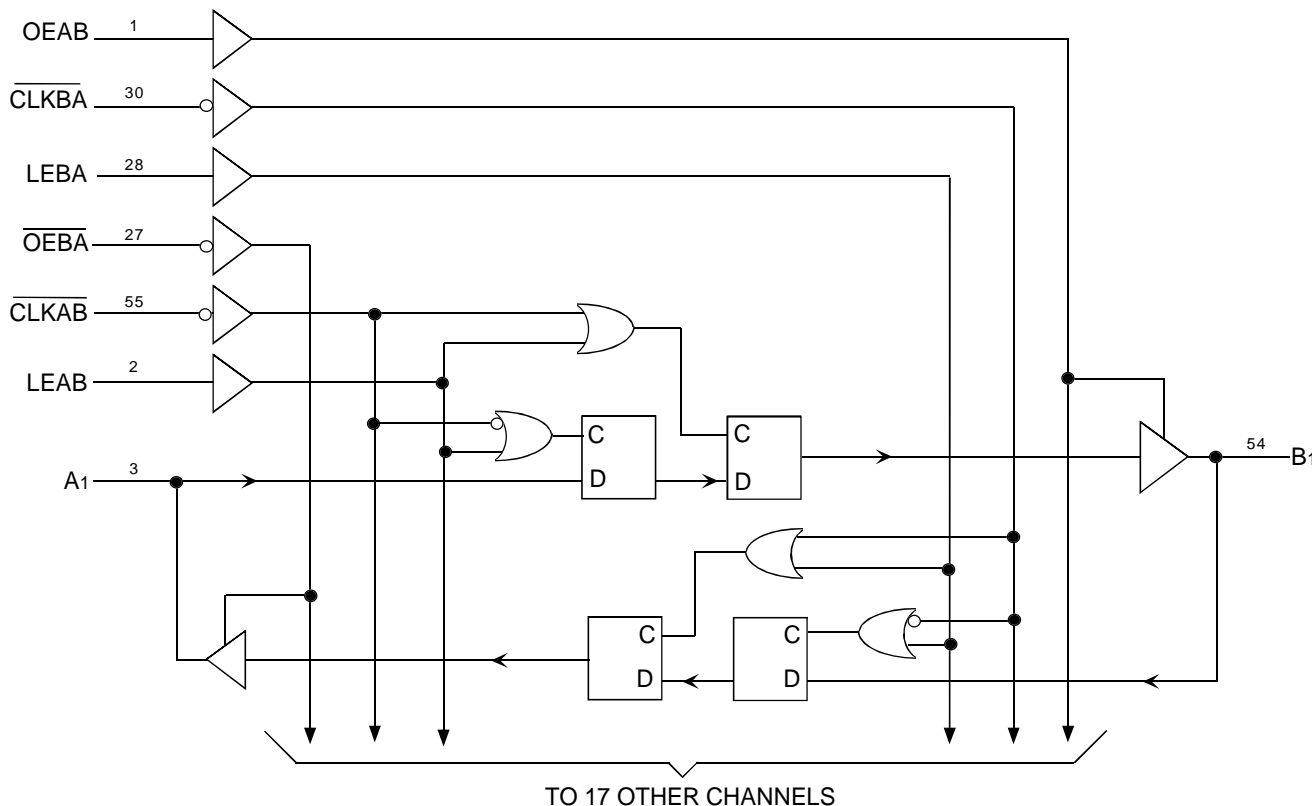

MILITARY AND COMMERCIAL TEMPERATURE RANGES

JULY 1999

## PIN CONFIGURATION

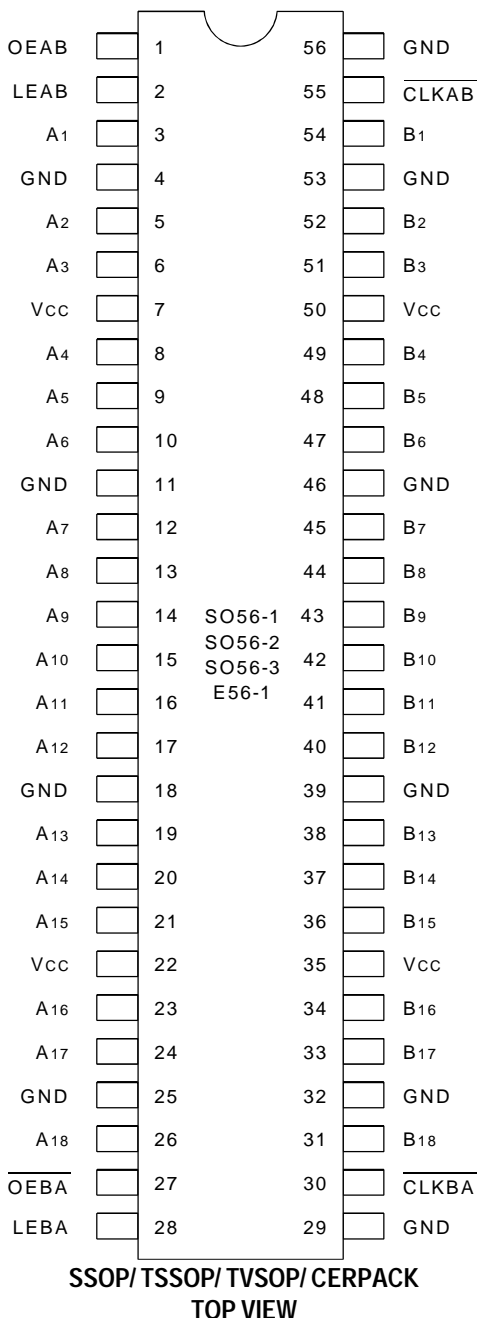

## PIN DESCRIPTION

| Pin Names          | Description                                  |
|--------------------|--|
| OEAB               | A-to-B Output Enable Input                   |
| $\overline{OEBA}$  | B-to-A Output Enable Input (Active LOW)      |
| LEAB               | A-to-B Latch Enable Input                    |
| LEBA               | B-to-A Latch Enable Input                    |
| $\overline{CLKAB}$ | A-to-B Clock Input (Active LOW)              |
| $\overline{CLKBA}$ | B-to-A Clock Input (Active LOW)              |
| Ax                 | A-to-B Data Inputs or B-to-A 3-State Outputs |
| Bx                 | B-to-A Data Inputs or A-to-B 3-State Outputs |

## ABSOLUTE MAXIMUM RATINGS(1)

| Symbol           | Description                          | Max                  | Unit |
|------------------|--------------------------------------|----------------------|------|
| $V_{TERM}^{(2)}$ | Terminal Voltage with Respect to GND | -0.5 to +7           | V    |
| $V_{TERM}^{(3)}$ | Terminal Voltage with Respect to GND | -0.5 to $V_{CC}+0.5$ | V    |
| TSTG             | Storage Temperature                  | -65 to +150          | °C   |
| I <sub>OUT</sub> | DC Output Current                    | -60 to +120          | mA   |

5v16-link

### NOTES:

- Stresses greater than those listed under ABSOLUTE MAXIMUM RATINGS may cause permanent damage to the device. This is a stress rating only and functional operation of the device at these or any other conditions above those indicated in the operational sections of this specification is not implied. Exposure to absolute maximum rating conditions for extended periods may affect reliability.
- All device terminals except FCT162XXXT Output and I/O terminals.
- Output and I/O terminals for FCT162XXXT.

## CAPACITANCE ( $T_A = +25^\circ\text{C}$ , $f = 1.0\text{MHz}$ )

| Symbol           | Parameter <sup>(1)</sup> | Conditions            | Typ. | Max. | Unit |
|------------------|--------------------------|-----------------------|------|------|------|
| C <sub>IN</sub>  | Input Capacitance        | $V_{IN} = 0\text{V}$  | 3.5  | 6    | pF   |
| C <sub>OUT</sub> | Output Capacitance       | $V_{OUT} = 0\text{V}$ | 3.5  | 8    | pF   |

5v16-link

### NOTE:

- This parameter is measured at characterization but not tested.

## FUNCTION TABLE<sup>(1,4)</sup>

| Inputs |      |                    |    | Outputs          |  |
|--------|------|--------------------|----|------------------|--|
| OEAB   | LEAB | $\overline{CLKAB}$ | Ax | Bx               |  |
| L      | X    | X                  | X  | Z                |  |
| H      | H    | X                  | L  | L                |  |
| H      | H    | X                  | H  | H                |  |
| H      | L    | ↓                  | L  | L                |  |
| H      | L    | ↓                  | H  | H                |  |
| H      | L    | H                  | X  | B <sup>(2)</sup> |  |
| H      | L    | L                  | X  | B <sup>(3)</sup> |  |

### NOTES:

- A-to-B data flow is shown. B-to-A data flow is similar but uses  $\overline{OEBA}$ , LEBA, and  $\overline{CLKBA}$ .
- Output level before the indicated steady-state input conditions were established.
- Output level before the indicated steady-state input conditions were established, provided that  $\overline{CLKAB}$  was LOW before LEAB went LOW.
- H = HIGH Voltage Level  
L = LOW Voltage Level  
X = Don't Care  
Z = High-impedance  
↓ = HIGH-to-LOW Transition

## DC ELECTRICAL CHARACTERISTICS OVER OPERATING RANGE

Following Conditions Apply Unless Otherwise Specified:

Commercial:  $T_A = -40^\circ\text{C}$  to  $+85^\circ\text{C}$ ,  $V_{CC} = 5.0\text{V} \pm 10\%$ ; Military:  $T_A = -55^\circ\text{C}$  to  $+125^\circ\text{C}$ ,  $V_{CC} = 5.0\text{V} \pm 10\%$

| Symbol                              | Parameter                                      | Test Conditions <sup>(1)</sup>                             |                     | Min. | Typ. <sup>(2)</sup> | Max.    | Unit          |
|-------------------------------------|--|--|---------------------|------|---------------------|---------|---------------|
| $V_{IH}$                            | Input HIGH Level                               | Guaranteed Logic HIGH Level                                |                     | 2    | —                   | —       | V             |
| $V_{IL}$                            | Input LOW Level                                | Guaranteed Logic LOW Level                                 |                     | —    | —                   | 0.8     | V             |
| $I_{IH}$                            | Input HIGH Current (Input pins) <sup>(5)</sup> | $V_{CC} = \text{Max.}$                                     | $V_I = V_{CC}$      | —    | —                   | $\pm 1$ | $\mu\text{A}$ |
|                                     | Input HIGH Current (I/O pins) <sup>(5)</sup>   |  |                     | —    | —                   | $\pm 1$ |               |
| $I_{IL}$                            | Input LOW Current (Input pins) <sup>(5)</sup>  |  | $V_I = \text{GND}$  | —    | —                   | $\pm 1$ |               |
|                                     | Input LOW Current (I/O pins) <sup>(5)</sup>    |  |                     | —    | —                   | $\pm 1$ |               |
| $I_{OZH}$                           | High Impedance Output Current                  | $V_{CC} = \text{Max.}$                                     | $V_O = 2.7\text{V}$ | —    | —                   | $\pm 1$ | $\mu\text{A}$ |
| $I_{OZL}$                           | (3-State Output pins) <sup>(5)</sup>           |  | $V_O = 0.5\text{V}$ | —    | —                   | $\pm 1$ |               |
| $V_{IK}$                            | Clamp Diode Voltage                            | $V_{CC} = \text{Min.}, I_{IN} = -18\text{mA}$              |                     | —    | -0.7                | -1.2    | V             |
| $I_{OS}$                            | Short Circuit Current                          | $V_{CC} = \text{Max.}, V_O = \text{GND}^{(3)}$             |                     | -80  | -140                | -250    | mA            |
| $V_H$                               | Input Hysteresis                               | —  |                     | —    | 100                 | —       | mV            |
| $I_{CCL}$<br>$I_{CCH}$<br>$I_{CCZ}$ | Quiescent Power Supply Current                 | $V_{CC} = \text{Max.}$<br>$V_{IN} = \text{GND or } V_{CC}$ |                     | —    | 5                   | 500     | $\mu\text{A}$ |

5v16-link

## OUTPUT DRIVE CHARACTERISTICS

| Symbol    | Parameter           | Test Conditions <sup>(1)</sup>  |                                | Min. | Typ. <sup>(2)</sup> | Max. | Unit |
|-----------|---------------------|---|--------------------------------|------|---------------------|------|------|
| $I_{ODL}$ | Output LOW Current  | $V_{CC} = 5\text{V}, V_{IN} = V_{IH} \text{ or } V_{IL}, V_O = 1.5\text{V}^{(3)}$ |                                | 60   | 115                 | 200  | mA   |
| $I_{ODH}$ | Output HIGH Current | $V_{CC} = 5\text{V}, V_{IN} = V_{IH} \text{ or } V_{IL}, V_O = 1.5\text{V}^{(3)}$ |                                | -60  | -115                | -200 | mA   |
| $V_{OH}$  | Output HIGH Voltage | $V_{CC} = \text{Min.}$<br>$V_{IN} = V_{IH} \text{ or } V_{IL}$                    | $I_{OH} = -16\text{mA MIL.}$   | 2.4  | 3.3                 | —    | V    |
|           |                     |   | $I_{OH} = -24\text{mA COM'L.}$ |      |                     |      |      |
| $V_{OL}$  | Output LOW Voltage  | $V_{CC} = \text{Min.}$<br>$V_{IN} = V_{IH} \text{ or } V_{IL}$                    | $I_{OL} = 16\text{mA MIL.}$    | —    | 0.3                 | 0.55 | V    |
|           |                     |   | $I_{OL} = 24\text{mA COM'L.}$  |      |                     |      |      |

5v16-link

### NOTES:

- For conditions shown as Max. or Min., use appropriate value specified under Electrical Characteristics for the applicable device type.
- Typical values are at  $V_{CC} = 5.0\text{V}$ ,  $+25^\circ\text{C}$  ambient.
- Not more than one output should be shorted at one time. Duration of the test should not exceed one second.
- Duration of the condition can not exceed one second.
- The test limit for this parameter is  $\pm 5\mu\text{A}$  at  $T_A = -55^\circ\text{C}$ .

## POWER SUPPLY CHARACTERISTICS

| Symbol          | Parameter                                      | Test Conditions <sup>(1)</sup>   |  | Min. | Typ. <sup>(2)</sup> | Max.                | Unit             |
|-----------------|--|--|--|------|---------------------|---------------------|------------------|
| $\Delta I_{CC}$ | Quiescent Power Supply Current TTL Inputs HIGH | $V_{CC} = \text{Max.}$<br>$V_{IN} = 3.4V^{(3)}$  |  | —    | 0.5                 | 1.5                 | mA               |
| $I_{CCD}$       | Dynamic Power Supply Current <sup>(4)</sup>    | $V_{CC} = \text{Max.}, \text{Outputs Open}$<br>$OEAB = \overline{OEBA} = V_{CC} \text{ or GND}$<br>One Input Toggling<br>50% Duty Cycle  | $V_{IN} = V_{CC}$<br>$V_{IN} = \text{GND}$ | —    | 75                  | 120                 | $\mu A /$<br>MHz |
| $I_C$           | Total Power Supply Current <sup>(6)</sup>      | $V_{CC} = \text{Max.}, \text{Outputs Open}$<br>$f_{CP} = 10\text{MHz} (\overline{CLKAB})$<br>50% Duty Cycle<br>$OEAB = \overline{OEBA} = V_{CC}$<br>$LEAB = \text{GND}$<br>One Bit Toggling<br>$f_i = 5\text{MHz}$<br>50% Duty Cycle         | $V_{IN} = V_{CC}$<br>$V_{IN} = \text{GND}$ | —    | 0.8                 | 1.7                 | mA               |
|                 |  |  | $V_{IN} = 3.4V$<br>$V_{IN} = \text{GND}$   | —    | 1.3                 | 3.2                 |                  |
|                 |  | $V_{CC} = \text{Max.}, \text{Outputs Open}$<br>$f_{CP} = 10\text{MHz} (\overline{CLKAB})$<br>50% Duty Cycle<br>$OEAB = \overline{OEBA} = V_{CC}$<br>$LEAB = \text{GND}$<br>Eighteen Bits Toggling<br>$f_i = 2.5\text{MHz}$<br>50% Duty Cycle | $V_{IN} = V_{CC}$<br>$V_{IN} = \text{GND}$ | —    | 3.8                 | 6.5 <sup>(5)</sup>  |                  |
|                 |  |  | $V_{IN} = 3.4V$<br>$V_{IN} = \text{GND}$   | —    | 8.5                 | 20.8 <sup>(5)</sup> |                  |

### NOTES:

- For conditions shown as Max. or Min., use appropriate value specified under Electrical Characteristics for the applicable device type.
- Typical values are at  $V_{CC} = 5.0V$ ,  $+25^\circ C$  ambient.
- Per TTL driven input ( $V_{IN} = 3.4V$ ). All other inputs at  $V_{CC}$  or  $\text{GND}$ .
- This parameter is not directly testable, but is derived for use in Total Power Supply Calculations.
- Values for these conditions are examples of the  $I_{CC}$  formula. These limits are guaranteed but not tested.
- $I_C = I_{\text{QUIESCENT}} + I_{\text{INPUTS}} + I_{\text{DYNAMIC}}$   
 $I_C = I_{CC} + \Delta I_{CC} D_{HNT} + I_{CCD} (f_{CP} N_{CP} / 2 + f_i N_i)$   
 $I_{CC} = \text{Quiescent Current} (I_{CCL}, I_{CCH} \text{ and } I_{CCZ})$   
 $\Delta I_{CC} = \text{Power Supply Current for a TTL High Input} (V_{IN} = 3.4V)$   
 $D_H = \text{Duty Cycle for TTL Inputs High}$   
 $N_T = \text{Number of TTL Inputs at } D_H$   
 $I_{CCD} = \text{Dynamic Current Caused by an Input Transition Pair (HLH or LHL)}$   
 $f_{CP} = \text{Clock Frequency for Register Devices (Zero for Non-Register Devices)}$   
 $N_{CP} = \text{Number of Clock Inputs at } f_{CP}$   
 $f_i = \text{Input Frequency}$   
 $N_i = \text{Number of Inputs at } f_i$

## SWITCHING CHARACTERISTICS OVER OPERATING RANGE

| Symbol                               | Parameter  | Condition <sup>(1)</sup> | FCT162500AT         |      |                     |      | FCT162500CT         |      |                     |      | FCT162500ET         |      |                     |      | Unit |
|--------------------------------------|--|--------------------------|---------------------|------|---------------------|------|---------------------|------|---------------------|------|---------------------|------|---------------------|------|------|
|                                      |  |                          | Com'l.              |      | Mil.                |      | Com'l.              |      | Mil.                |      | Com'l.              |      | Mil.                |      |      |
|                                      |  |                          | Min. <sup>(2)</sup> | Max. | Min. <sup>(2)</sup> | Max. | Min. <sup>(2)</sup> | Max. | Min. <sup>(2)</sup> | Max. | Min. <sup>(2)</sup> | Max. | Min. <sup>(2)</sup> | Max. |      |
| f <sub>MAX</sub>                     | CLKAB or CLKBA frequency <sup>(4)</sup>                  | C <sub>L</sub> = 50pF    | —                   | 150  | —                   | 150  | —                   | 150  | —                   | 150  | —                   | 150  | —                   | —    | MHz  |
| t <sub>PLH</sub><br>t <sub>PHL</sub> | Propagation Delay<br>Ax to Bx or Bx to Ax                | RL = 500Ω                | 1.5                 | 5.1  | 1.5                 | 5.6  | 1.5                 | 4.6  | 1.5                 | 4.6  | —                   | 3.8  | —                   | —    | ns   |
| t <sub>PLH</sub><br>t <sub>PHL</sub> | Propagation Delay<br>LEBA to Ax, LEAB to Bx              |                          | 1.5                 | 5.6  | 1.5                 | 6    | 1.5                 | 5.3  | 1.5                 | 5.6  | —                   | 4.2  | —                   | —    | ns   |
| t <sub>PLH</sub><br>t <sub>PHL</sub> | Propagation Delay<br>CLKBA to Ax, CLKAB to Bx            |                          | 1.5                 | 5.6  | 1.5                 | 6    | 1.5                 | 5.3  | 1.5                 | 5.4  | —                   | 4.2  | —                   | —    | ns   |
| t <sub>PZH</sub><br>t <sub>PZL</sub> | Output Enable Time<br>OEBA to Ax, OEAB to Bx             |                          | 1.5                 | 6    | 1.5                 | 6.4  | 1.5                 | 5.6  | 1.5                 | 6    | —                   | 4.8  | —                   | —    | ns   |
| t <sub>PHZ</sub><br>t <sub>PLZ</sub> | Output Disable Time<br>OEBA to Ax, OEAB to Bx            |                          | 1.5                 | 5.6  | 1.5                 | 6    | 1.5                 | 5.2  | 1.5                 | 5.6  | —                   | 4    | —                   | —    | ns   |
| t <sub>SU</sub>                      | Set-up Time, HIGH or LOW<br>Ax to CLKAB, Bx to CLKBA     |                          | 3                   | —    | 3                   | —    | 3                   | —    | 3                   | —    | 2.4                 | —    | —                   | —    | ns   |
| t <sub>H</sub>                       | Hold Time, HIGH or LOW<br>Ax to CLKAB, Bx to CLKBA       |                          | 0                   | —    | 0                   | —    | 0                   | —    | 0                   | —    | 0                   | —    | —                   | —    | ns   |
| t <sub>SU</sub>                      | Set-up Time<br>HIGH or LOW<br>Ax to LEAB,<br>Bx to LEBA  | Clock<br>HIGH            | 3                   | —    | 3                   | —    | 3                   | —    | 3                   | —    | 2                   | —    | —                   | —    | ns   |
|                                      |  | Clock<br>LOW             | 1.5                 | —    | 1.5                 | —    | 1.5                 | —    | 1.5                 | —    | 1.5                 | —    | —                   | —    | ns   |
| t <sub>H</sub>                       | Hold Time, HIGH or LOW<br>Ax to LEAB, Bx to LEBA         |                          | 1.5                 | —    | 1.5                 | —    | 1.5                 | —    | 1.5                 | —    | 0.5                 | —    | —                   | —    | ns   |
| t <sub>W</sub>                       | LEAB or LEBA Pulse Width HIGH <sup>(4)</sup>             |                          | 3                   | —    | 3                   | —    | 3                   | —    | 3                   | —    | 3                   | —    | —                   | —    | ns   |
| t <sub>W</sub>                       | CLKAB or CLKBA Pulse Width<br>HIGH or LOW <sup>(4)</sup> |                          | 3                   | —    | 3                   | —    | 3                   | —    | 3                   | —    | 3                   | —    | —                   | —    | ns   |
| t <sub>SK(0)</sub>                   | Output Skew <sup>(3)</sup>                               |                          | —                   | 0.5  | —                   | 0.5  | —                   | 0.5  | —                   | 0.5  | —                   | 0.5  | —                   | —    | ns   |

### NOTES:

1. See test circuits and waveforms.
2. Minimum limits are guaranteed but not tested on Propagation Delays.
3. Skew between any two outputs of the same package switching in the same direction. This parameter is guaranteed by design.
4. This parameter is guaranteed but not tested.

## TEST CIRCUITS AND WAVEFORMS

### TEST CIRCUITS FOR ALL OUTPUTS

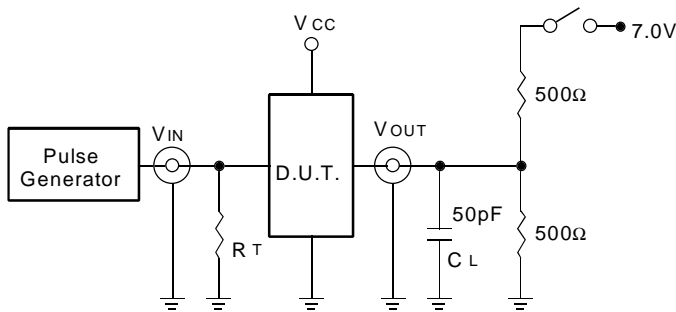

### SWITCH POSITION

| Test            | Switch |
|-----------------|--------|
| Open Drain      | Closed |
| Disable Low     |        |
| Enable Low      |        |
| All Other Tests | Open   |

5v16-link

### DEFINITIONS:

CL = Load capacitance: includes jig and probe capacitance.

RT = Termination resistance: should be equal to ZOUT of the Pulse Generator.

### SET-UP, HOLD, AND RELEASE TIMES

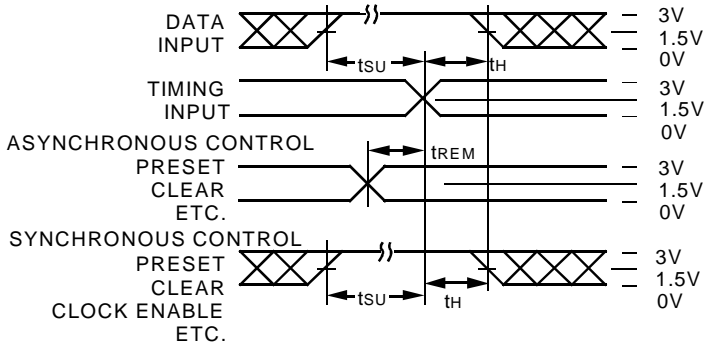

### PULSE WIDTH

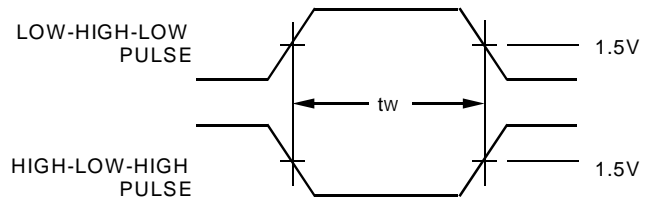

### PROPAGATION DELAY

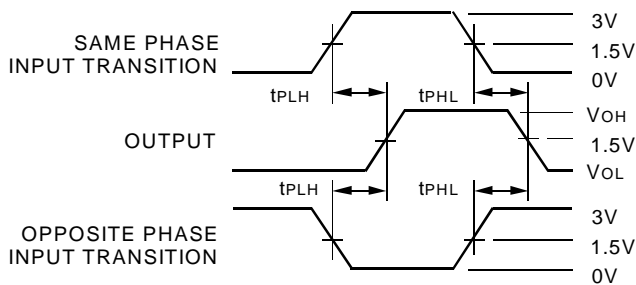

### ENABLE AND DISABLE TIMES

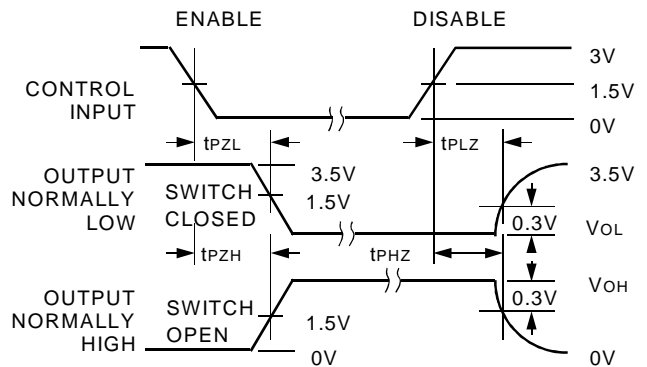

### NOTES:

1. Diagram shown for input Control Enable-LOW and input Control Disable-HIGH.
2. Pulse Generator for All Pulses: Rate  $\leq 1.0\text{MHz}$ ;  $t_f \leq 2.5\text{ns}$ ;  $t_r \leq 2.5\text{ns}$ .

**ORDERING INFORMATION**

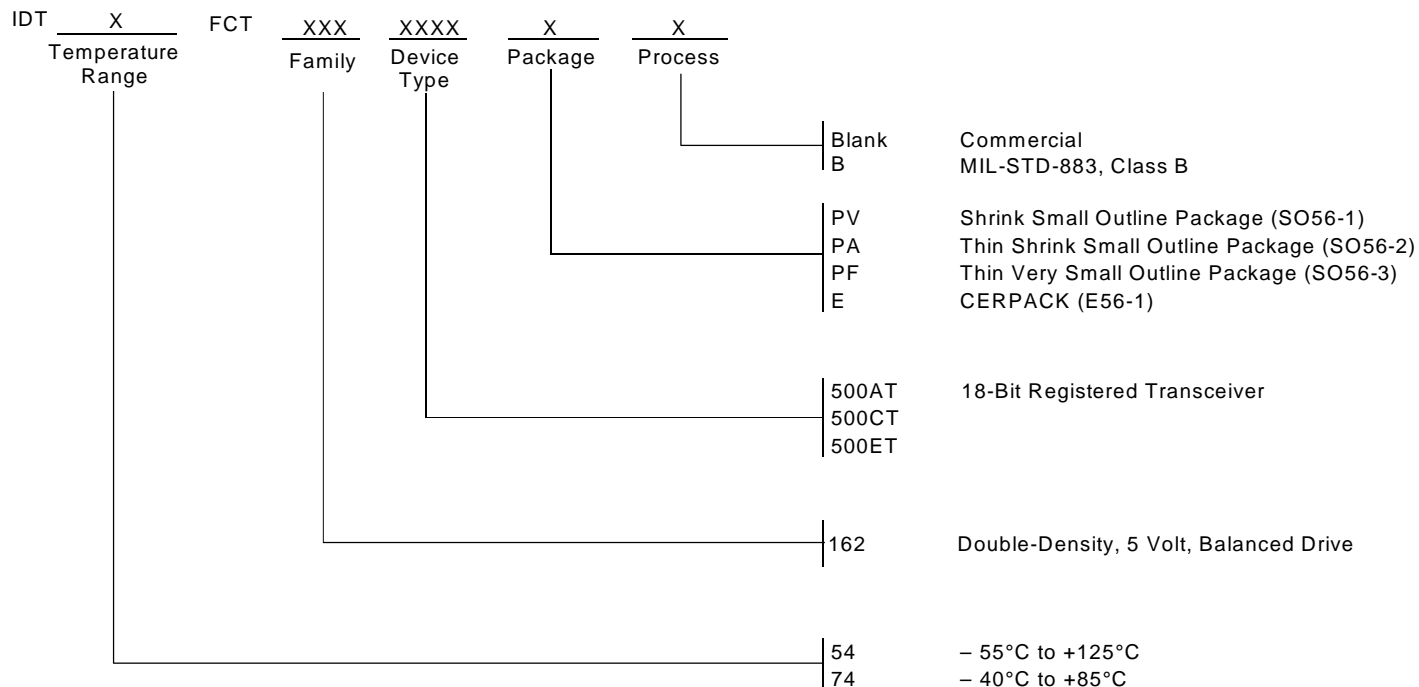

**CORPORATE HEADQUARTERS**  
 2975 Stender Way  
 Santa Clara, CA 95054

**for SALES:**  
 800-345-7015 or 408-727-6116  
 fax: 408-492-8674  
[www.idt.com](http://www.idt.com)\*

\*To search for sales office near you, please click the sales button found on our home page or dial the 800# above and press 2.  
 The IDT logo is a registered trademark of Integrated Device Technology, Inc.