

## FEATURES/BENEFITS

- 5V tolerant inputs and outputs
- 25Ω series resistor for low switching noise
- 10μA I<sub>CCQ</sub> quiescent power supply current
- Hot insertable
- 2.0V–3.6V V<sub>CC</sub> supply operation
- ±12mA balanced output drive
- Power down high impedance inputs and outputs
- t<sub>PD</sub> = 7.0ns max.
- Input hysteresis for noise immunity
- Meets or exceeds JEDEC Standard 36 specifications
- Multiple power and ground pins for low noise
- Operating temperature range:  
–40°C to 85°C
- Latch-up performance exceeds 500mA
- ESD performance:  
Human body model > 2000V  
Machine model > 200V
- Packages available:  
48-pin TSSOP  
48-pin SSOP

## DESCRIPTION

The QS74LVC162244 is a 16-bit bus interface buffer with three-state output that is ideal for driving address, clocks, and data buses. Output enables are used to enable or disable Y ports by placing them in a high impedance condition. The QS74LVC162244 with integrated output resistor is ideally suited for low noise environments where reduced output overshoot and undershoot are critical requirements. The 3.3V LVC family features low power, low switching noise, and fast switching speeds for low power portable applications as well as high-end, advanced workstation applications. 5V tolerant inputs and outputs allow these LVC products to be used in mixed 5V and 3.3V applications. Easy board layout is facilitated by the use of flow-through pinouts and byte enable controls provide architectural flexibility for systems designers. To accommodate hot-plug or live insertion applications, this product is designed not to load an active bus when V<sub>CC</sub> is removed. However, during power up or power down sequence, OE should be tied to V<sub>CC</sub> to ensure high-impedance state on the outputs.

**Figure 1. Functional Block Diagram**

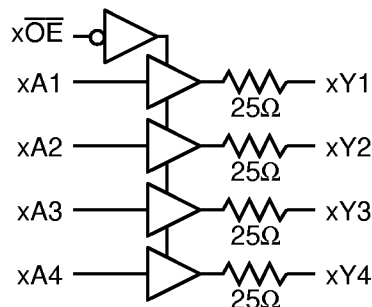

**Figure 2. Pin Configuration**  
(All Pins Top View)

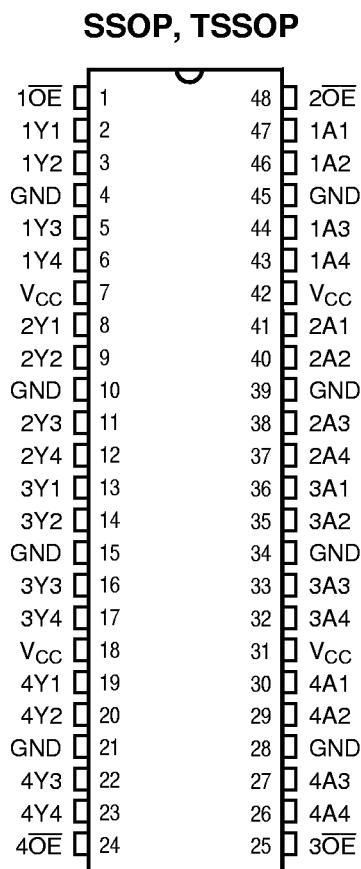

**Table 1. Pin Description**

Name	Description
$\overline{xOE}$	Three-State Output Enable Inputs
$xAx$	Data Inputs
$xYx$	Three-State Outputs

**Table 2. Function Table**

Inputs		Outputs
$\overline{xOE}$	$xAx$	$xYx$
L	L	L
L	H	H
H	X	Hi-Z

**Table 3. Absolute Maximum Ratings**

Supply Voltage to Ground .....	-0.5V to 7.0V
DC Output Voltage $V_{OUT}$	
Outputs HIGH-Z .....	-0.5V to 7.0V
Outputs Active .....	-0.5V to $V_{CC} + 0.5V$
DC Input Voltage $V_{IN}$ .....	-0.5V to 7.0V
DC Input Diode Current with $V_{IN} < 0$ .....	-50mA
DC Output Diode Current	
$V_O < 0$ .....	-50mA
$V_O > V_{CC}$ .....	50mA
DC Output Source/Sink Current ( $I_{OH}/I_{OL}$ ) .....	$\pm 50mA$
DC Supply Current per Supply Pin .....	$\pm 100mA$
DC Ground Current per Ground Pin .....	$\pm 100mA$
$T_{STG}$ Storage Temperature .....	-65°C to 150°C

**Note:** Stresses greater than those listed under ABSOLUTE MAXIMUM RATINGS may cause permanent damage to this device resulting in functional or reliability type failures.

**Table 4. Recommended Operating Conditions**

Symbol	Parameter	Min	Max	Unit	
V <sub>CC</sub>	Supply Voltage, Operating	2.0	3.6	V	
	Supply Voltage, Data Retention Only	1.5	3.6		
V <sub>IH</sub>	Input HIGH Voltage	2.0	—	V	
V <sub>IL</sub>	Input LOW Voltage	—	0.8	V	
V <sub>IN</sub>	Input Voltage	0	5.5	V	
V <sub>OUT</sub>	Output Voltage in Active State	0	V <sub>CC</sub>	V	
	Output Voltage in "OFF" State	0	5.5		
I <sub>OH</sub>	Output Current HIGH	V <sub>CC</sub> = 3.0–3.6V	—	–12	mA
		V <sub>CC</sub> = 2.7V	—	–8	
I <sub>OL</sub>	Output Current LOW	V <sub>CC</sub> = 3.0–3.6V	—	12	mA
		V <sub>CC</sub> = 2.7V	—	8	
Δt/Δv	Input Transition Slew Rate	—	10	ns/V	
T <sub>A</sub>	Operating Free Air Temperature	–40	85	°C	

**Table 5. DC Electrical Characteristics Over Operating Range**

Industrial Temperature Range, T<sub>A</sub> = –40°C to 85°C

Symbol	Parameter	Test Conditions	Min	Typ <sup>(1)</sup>	Max	Unit
V <sub>OH</sub>	Output HIGH Voltage	V <sub>CC</sub> = 2.7V, I <sub>OH</sub> = –100μA	V <sub>CC</sub> – 0.2	—	—	V
		V <sub>CC</sub> = 2.7V, I <sub>OH</sub> = –4mA	2.2	—	—	
		V <sub>CC</sub> = 3.0V, I <sub>OH</sub> = –6mA	2.4	—	—	
		V <sub>CC</sub> = 2.7V, I <sub>OH</sub> = –8mA	2.0	—	—	
		V <sub>CC</sub> = 3.0V, I <sub>OH</sub> = –12mA	2.2	—	—	
V <sub>OL</sub>	Output LOW Voltage	V <sub>CC</sub> = 2.7V, I <sub>OL</sub> = 100μA	—	—	0.2	V
		V <sub>CC</sub> = 2.7V, I <sub>OL</sub> = 4mA	—	—	0.4	
		V <sub>CC</sub> = 3.0V, I <sub>OL</sub> = 6mA	—	—	0.55	
		V <sub>CC</sub> = 2.7V, I <sub>OL</sub> = 8mA	—	—	0.6	
		V <sub>CC</sub> = 3.0V, I <sub>OL</sub> = 12mA	—	—	0.8	
V <sub>IK</sub>	Input Clamp Voltage	V <sub>CC</sub> = 2.7V, I <sub>IN</sub> = –18mA	—	–0.7	–1.2	V
I <sub>I</sub>	Input Leakage Current	V <sub>I</sub> = 0V, V <sub>I</sub> = 5.5V, V <sub>CC</sub> = 3.6V	—	—	±1.0	μA
I <sub>OZ</sub>	High-Z I/O Leakage	V <sub>O</sub> = 0V, V <sub>O</sub> = 5.5V, V <sub>I</sub> = V <sub>IH</sub> or V <sub>IL</sub> , V <sub>CC</sub> = 3.6V	—	—	±1.0	μA
I <sub>OFF</sub>	Power Off Leakage	V <sub>CC</sub> = 0V, V <sub>I</sub> or V <sub>O</sub> = 5.5V	—	—	10	μA
I <sub>CC</sub>	Quiescent Power Supply Current	V <sub>CC</sub> = 3.6V, V <sub>IN</sub> = V <sub>CC</sub> or GND	—	0.1	10	μA
ΔI <sub>CC</sub>	Quiescent Power Supply Current per Control Inputs at TTL HIGH	V <sub>CC</sub> = 3.6V, V <sub>IN</sub> = V <sub>CC</sub> – 0.6V <sup>(2)</sup>	—	2.0	3.0	μA

**Notes:**

1. Typical values are at V<sub>CC</sub> = 3.3V and T<sub>A</sub> = 25°C.
2. Per TTL driven input. All other inputs at V<sub>CC</sub> or GND.

**Table 6. Dynamic Switching Characteristics**

Symbol	Parameter	Test Conditions	Typ <sup>(1)</sup>	Unit	
V <sub>OLP</sub>	Quiet Output Dynamic Peak V <sub>OL</sub>	C <sub>L</sub> = 50pF, V <sub>CC</sub> = 3.3V V <sub>IH</sub> = 3.3V, V <sub>IL</sub> = 0V	0.8	V	
V <sub>OLV</sub>	Quiet Output Dynamic Valley V <sub>OL</sub>	C <sub>L</sub> = 50pF, V <sub>CC</sub> = 3.3V V <sub>IH</sub> = 3.3V, V <sub>IL</sub> = 0V	0.8	V	
C <sub>PD</sub>	Power Dissipation	C <sub>L</sub> = 50pF, f = 10MHz, V <sub>CC</sub> = 3.3 ± 0.3V	Output Enable	20	pF
			Output Disable	4	

**Note:**

1. Typical values are at V<sub>CC</sub> = 3.3V, 25°C ambient.

**Table 7. Capacitance<sup>(1)</sup>**

Symbol	Pins	Conditions	Typ	Unit
C <sub>IN</sub>	Input Capacitance	V <sub>IN</sub> = 0V, V <sub>OUT</sub> = 0V, f = 1MHz	7.0	pF
C <sub>I/O</sub>	I/O Capacitance	V <sub>IN</sub> = 0V, V <sub>OUT</sub> = 0V, f = 1MHz	8.0	pF

**Note:**

1. Capacitance is characterized but not production tested.

**Table 8. Switching Characteristics Over Operating Range**

Industrial Temperature Range, T<sub>A</sub> = -40°C to 85°C.

C<sub>LOAD</sub> = 50pF, R<sub>LOAD</sub> = 500Ω unless otherwise noted.

Symbol	Description <sup>(1)</sup>	V <sub>CC</sub> = 3.3 ± 0.3V		V <sub>CC</sub> = 2.7V <sup>(2)</sup>		Unit
		Min	Max	Min	Max	
t <sub>PD</sub>	Propagation Delay xAx to xYx	1.5	7.0	1.5	8.0	ns
t <sub>EN</sub>	Output Enable Time xOE to xYx	1.5	9.0	1.5	10.0	ns
t <sub>DIS</sub>	Output Disable Time <sup>(2)</sup> xOE to xYx	1.5	7.0	1.5	8.0	ns
t <sub>SK(O)</sub>	Output Skew <sup>(3)</sup>	—	0.5	—	—	ns

**Notes:**

1. Minimums guaranteed but not tested. See Test Circuit and Waveforms.
2. Guaranteed by characterization.
3. Skew between any two outputs of the same package switching in the same direction. This parameter is guaranteed by characterization but not production tested.

TEST CIRCUIT AND WAVEFORMS

Figure 3. Test Circuit

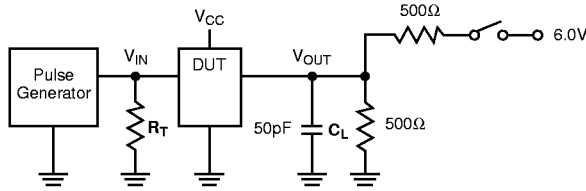

SWITCH POSITION	
Test	Switch
Open Drain	
Disable LOW	6V
Enable LOW	
Disable HIGH	GND
Enable HIGH	
All Other Inputs	Open

DEFINITIONS:  
 $C_L$  = Load capacitance: includes jig and probe capacitance.  
 $R_T$  = Termination resistance: should be equal to  $Z_{OUT}$  of the Pulse Generator.

Figure 4. Setup, Hold, and Release Timing

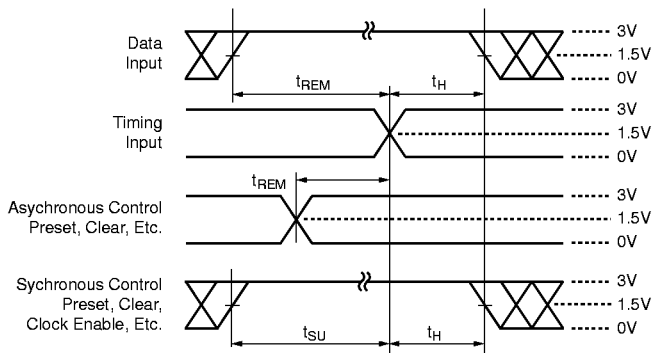

Figure 6. Pulse Width

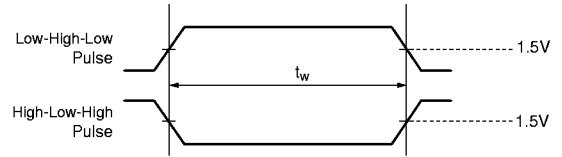
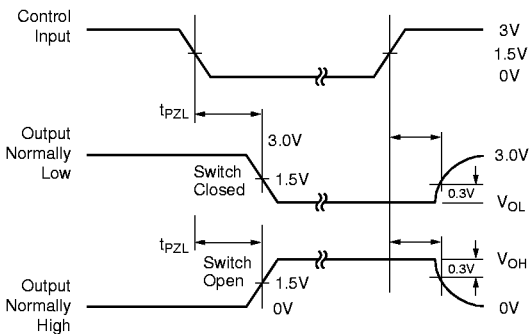

Figure 5. Enable and Disable Timing



Notes:

1. Input Control Enable = LOW and Input Control Disable = HIGH.
2. Pulse Generator for All Pulses: Rate  $\leq$  1.0MHz;  
 $Z_{OUT} \leq 50\Omega$ ;  $t_f, t_r \leq 2.5ns$ .

Figure 7. Propagation Delay

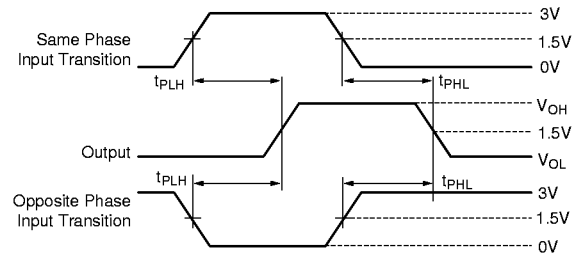

**ORDERING INFORMATION**

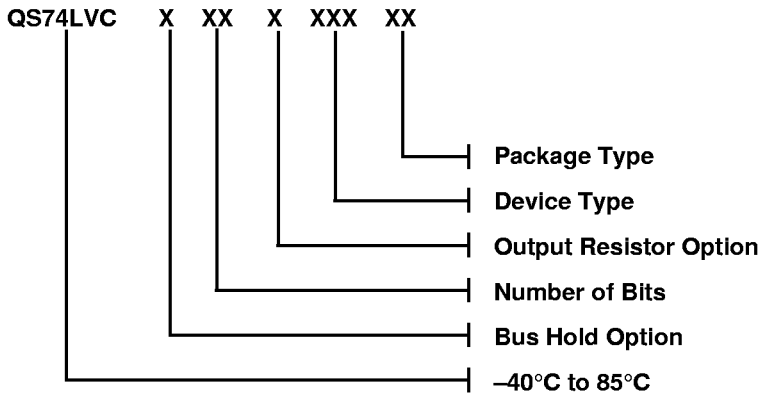

**Bus Hold Option:**  
Blank – No Bus Hold  
**Number of Bits:**  
16 – 16-Bit

**Output Resistor Option:**  
2 – Output Resistor

**Device Type:**  
244

**Package Type:**  
PV – SSOP, 300 mil  
PA – TSSOP, 240 mil