

ACTS244MS

Radiation Hardened Octal Non-Inverting Three-State Buffer

FN3187
Rev 1.00
January 1996

Features

- Devices QML Qualified in Accordance with MIL-PRF-38535
- Detailed Electrical and Screening Requirements are Contained in SMD# 5962-96718 and Intersil's QM Plan
- 1.25 Micron Radiation Hardened SOS CMOS
- Total Dose >300K RAD (Si)
- Single Event Upset (SEU) Immunity: $<1 \times 10^{-10}$ Errors/Bit/Day (Typ)
- SEU LET Threshold >100 MEV-cm²/mg
- Dose Rate Upset >10¹¹ RAD (Si)/s, 20ns Pulse
- Dose Rate Survivability >10¹² RAD (Si)/s, 20ns Pulse
- Latch-Up Free Under Any Conditions
- Military Temperature Range -55°C to +125°C
- Significant Power Reduction Compared to ALSTTL Logic
- DC Operating Voltage Range 4.5V to 5.5V
- Input Logic Levels
 - VIL = 0.8V Max
 - VIH = VCC/2 Min
- Input Current $\leq 1\mu\text{A}$ at VOL, VOH
- Fast Propagation Delay 14.5ns (Max), 10ns (Typ)

Description

The Intersil ACTS244MS is a Radiation Hardened Octal Non-Inverting Three-State Buffer having two active low enable inputs.

The ACTS244MS utilizes advanced CMOS/SOS technology to achieve high-speed operation. This device is a member of radiation hardened, high-speed, CMOS/SOS Logic Family.

The ACTS244MS is supplied in a 20 lead Ceramic Flatpack (K suffix) or a Dual-In-Line Ceramic Package (D suffix).

Pinouts

20 PIN CERAMIC DUAL-IN-LINE
MIL-STD-1835 DESIGNATOR CDIP2-T20,
LEAD FINISH C
TOP VIEW

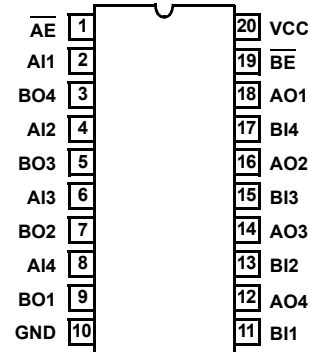

20 PIN CERAMIC FLATPACK
MIL-STD-1835 DESIGNATOR CDFP4-F20,
LEAD FINISH C
TOP VIEW

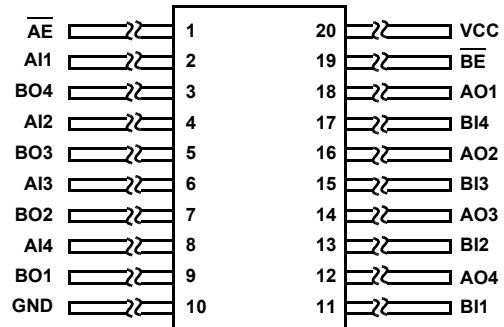

Ordering Information

PART NUMBER	TEMPERATURE RANGE	SCREENING LEVEL	PACKAGE
5962F9671801VRC	-55°C to +125°C	MIL-PRF-38535 Class V	20 Lead SBDIP
5962F9671801VXC	-55°C to +125°C	MIL-PRF-38535 Class V	20 Lead Ceramic Flatpack
ACTS244D/Sample	25°C	Sample	20 Lead SBDIP
ACTS244K/Sample	25°C	Sample	20 Lead Ceramic Flatpack
ACTS244HMSR	25°C	Die	Die

Functional Diagram

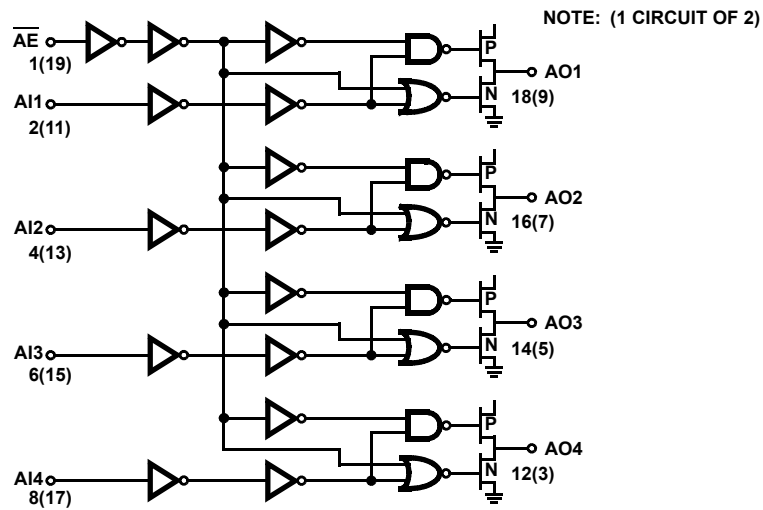

TRUTH TABLE

INPUTS		OUTPUT
$\overline{AE}, \overline{BE}$	AIn, BIn	AOn, BOn
L	L	L
L	H	H
H	X	Z

NOTE: H = High Voltage Level, L = Low Voltage Level, X = Immaterial, Z = High Impedance

Die Characteristics

DIE DIMENSIONS:

100 x 100 (mils)
 2.54 x 2.54 (mm)

METALLIZATION:

Type: AlSi
 Metal 1 Thickness: $7.125\text{k}\text{\AA} \pm 1.125\text{k}\text{\AA}$
 Metal 2 Thickness: $9\text{k}\text{\AA} \pm 1\text{k}\text{\AA}$

GLASSIVATION:

Type: SiO₂
 Thickness: $8\text{k}\text{\AA} \pm 1\text{k}\text{\AA}$

WORST CASE CURRENT DENSITY:

$< 2.0 \times 10^5 \text{A/cm}^2$

BOND PAD SIZE:

110 x 110 (μm)
 4.4 x 4.4 (mils)

Metallization Mask Layout

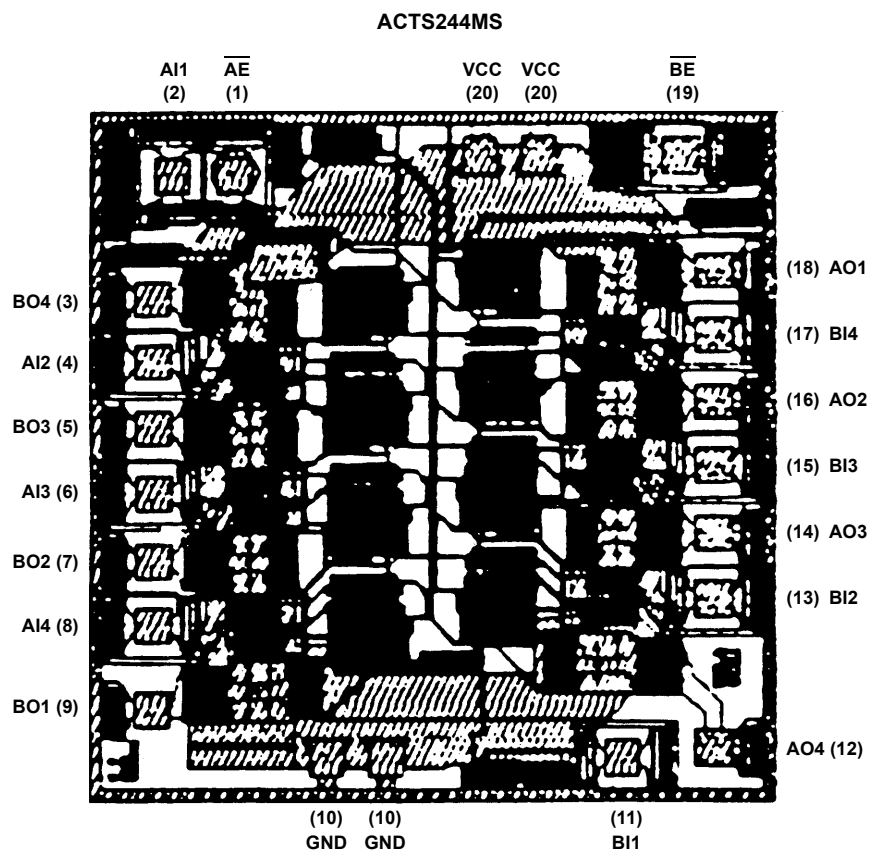

© Copyright Intersil Americas LLC 1999. All Rights Reserved.

All trademarks and registered trademarks are the property of their respective owners.

For additional products, see www.intersil.com/en/products.html

Intersil products are manufactured, assembled and tested utilizing ISO9001 quality systems as noted in the quality certifications found at www.intersil.com/en/support/qualandreliability.html

Intersil products are sold by description only. Intersil may modify the circuit design and/or specifications of products at any time without notice, provided that such modification does not, in Intersil's sole judgment, affect the form, fit or function of the product. Accordingly, the reader is cautioned to verify that datasheets are current before placing orders. Information furnished by Intersil is believed to be accurate and reliable. However, no responsibility is assumed by Intersil or its subsidiaries for its use; nor for any infringements of patents or other rights of third parties which may result from its use. No license is granted by implication or otherwise under any patent or patent rights of Intersil or its subsidiaries.

For information regarding Intersil Corporation and its products, see www.intersil.com