

## 16-bit buffer/line driver; (3-State)

74LVCH16241

## FEATURES

- Wide supply voltage range of 1.2V to 3.6V
- Complies with JEDEC standard no. 8-1A
- CMOS low power consumption
- MULTIBYTE™ flow-through standard pin-out architecture
- Low inductance multiple power and ground pins for minimum noise and ground bounce
- Direct interface with TTL levels
- All data inputs have bushold
- Output drive capability 50Ω transmission lines @ 85°C

## DESCRIPTION

The 74LVCH16241 is a high-performance, low-power, low-voltage, Si-gate CMOS device, superior to most advanced CMOS compatible TTL families.

The 74LVCH16241 is a 16-bit buffer/line driver with 3-State outputs. The 3-State outputs are controlled by the output enable inputs nOE and nOE. Schmitt-trigger action at all inputs makes the circuit highly tolerant for slower input rise and fall times. The device can be used as four 4-bit buffers, two 8-bit buffers or one 16-bit buffer.

## PIN CONFIGURATION

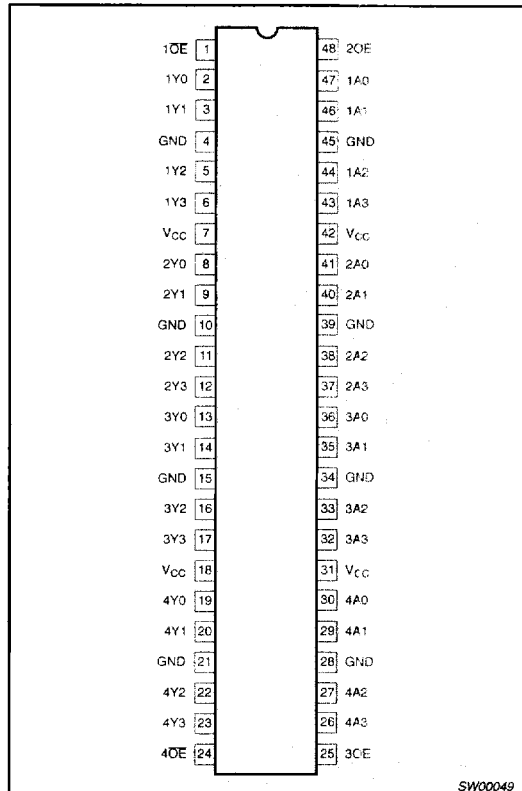

SW00049

## ORDERING INFORMATION

PACKAGES	TEMPERATURE RANGE	OUTSIDE NORTH AMERICA	NORTH AMERICA	DWG NUMBER
48-Pin Plastic SSOP Type III	-40°C to +85°C	74LVCH16241 DL	VCH16241 DL	SOT370-1
48-Pin Plastic TSSOP Type II	-40°C to +85°C	74LVCH16241 DGG	VCH16241 DGG	SOT362-1

## QUICK REFERENCE DATA

GND = 0 V; T<sub>amb</sub> = 25 °C; t<sub>r</sub> = t<sub>f</sub> ≤ 2.5 ns

SYMBOL	PARAMETER	CONDITIONS	TYPICAL	UNIT
t <sub>PHL</sub> /t <sub>PLH</sub>	Propagation delay nAn to nYn	C <sub>L</sub> = 50pF V <sub>CC</sub> = 3.3V	2.1	ns
C <sub>I</sub>	Input capacitance		5.0	pF
C <sub>PD</sub>	Power dissipation capacitance per buffer	V <sub>I</sub> = GND to V <sub>CC</sub> <sup>1</sup>	30	pF

## NOTES:

- C<sub>PD</sub> is used to determine the dynamic power dissipation (P<sub>D</sub> in μW):  
 $P_D = C_{PD} \times V_{CC}^2 \times f_i + \sum (C_L \times V_{CC}^2 \times f_o)$  where:  
 f<sub>i</sub> = input frequency in MHz; C<sub>L</sub> = output load capacity in pF;  
 f<sub>o</sub> = output frequency in MHz; V<sub>CC</sub> = supply voltage in V;  
 $\sum (C_L \times V_{CC}^2 \times f_o)$  = sum of outputs.

# 16-bit buffer/line driver; (3-State)

74LVCH16241

## PIN DESCRIPTION

PIN NUMBER	SYMBOL	NAME AND FUNCTION
1	1OE	Output enable input (active LOW)
2, 3, 5, 6	1Y0 to 1Y3	Data outputs
4, 10, 15, 21, 28, 34, 39, 45	GND	Ground (0V)
7, 18, 31, 42	V <sub>CC</sub>	Positive supply voltage
8, 9, 11, 12	2Y0 to 2Y3	Data outputs
13, 14, 16, 17	3Y0 to 3Y3	Data outputs
19, 20, 22, 23	4Y0 to 4Y3	Data outputs
24	4OE	Output enable input (active LOW)
25	3OE	Output enable input (active LOW)
30, 29, 27, 26	4A0 to 4A3	Data inputs
36, 35, 33, 32	3A0 to 3A3	Data inputs
41, 40, 38, 37	2A0 to 2A3	Data inputs
47, 46, 44, 43	1A0 to 1A3	Data inputs
48	2OE	Output enable input (active LOW)

## LOGIC SYMBOL (IEEE/EC)

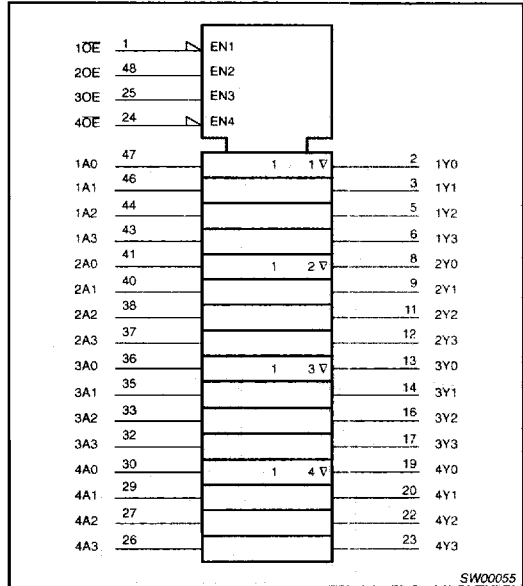

SW00055

## LOGIC SYMBOL

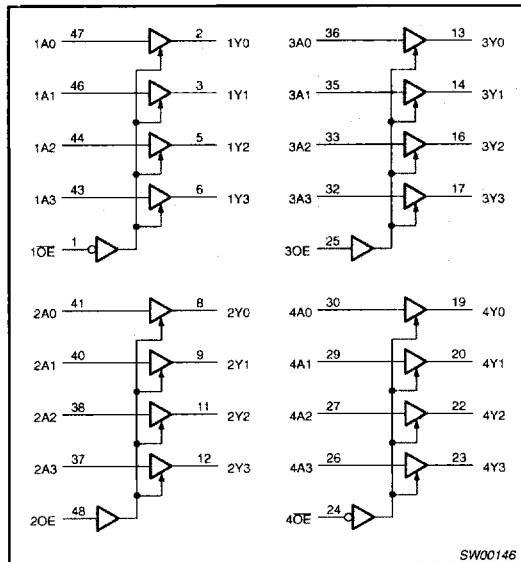

SW00146

## FUNCTION TABLES

INPUTS		OUTPUT
nOE	1An, 4An	1Yn, 4Yn
L	H	H
L	L	L
H	X	Z

INPUTS		OUTPUT
nOE	2An, 3An	2Yn, 3Yn
H	H	H
H	L	L
L	X	Z

H = HIGH voltage level  
 L = LOW voltage level  
 X = don't care  
 Z = high impedance OFF-state

## 16-bit buffer/line driver; (3-State)

74LVCH16241

## BUSHOLD CIRCUIT

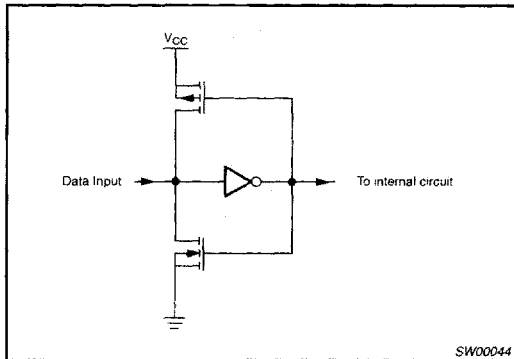
ABSOLUTE MAXIMUM RATINGS<sup>1, 2</sup>

In accordance with the Absolute Maximum Rating System (IEC 134)  
 Voltages are referenced to GND (ground = 0V)

SYMBOL	PARAMETER	CONDITIONS	RATING	UNIT
$V_{CC}$	DC supply voltage		-0.5 to +4.6	V
$I_{IK}$	DC input diode current	$V_I < 0$	-50	mA
$V_I$	DC input voltage	For control pins only <sup>3</sup>	-0.5 to +5.5	V
$V_I$	DC input voltage	For data inputs only <sup>3</sup>	-0.5 to $V_{CC} + 0.5$	V
$I_{OK}$	DC output diode current	$V_O > V_{CC}$ or $V_O < 0$	$\pm 50$	mA
$V_{OUT}$	DC output voltage	Note 3	-0.5 to $V_{CC} + 0.5$	V
$I_{OUT}$	DC output source or sink current	$V_O = 0$ to $V_{CC}$	$\pm 50$	mA
$I_{GND}, I_{CC}$	DC $V_{CC}$ or GND current		$\pm 100$	mA
$T_{stg}$	Storage temperature range		-60 to +150	$^{\circ}C$
$P_{TOT}$	Power dissipation per package -plastic medium-shrink SQ (SSOP)	For temperature range: -40 to +125 $^{\circ}C$ above +55 $^{\circ}C$ derate linearly with 11.3 mW/K above +55 $^{\circ}C$ derate linearly with 8 mW/K	850	mW
	-plastic mini-pack (TSSOP)		600	

## NOTES:

- Stresses beyond those listed may cause permanent damage to the device. These are stress ratings only and functional operation of the device at these or any other conditions beyond those indicated under "recommended operating conditions" is not implied. Exposure to absolute-maximum-rated conditions for extended periods may affect device reliability.
- The performance capability of a high-performance integrated circuit in conjunction with its thermal environment can create junction temperatures which are detrimental to reliability. The maximum junction temperature of this integrated circuit should not exceed 150 $^{\circ}C$ .
- The input and output voltage ratings may be exceeded if the input and output current ratings are observed.

## 16-bit buffer/line driver; (3-State)

74LVCH16241

## RECOMMENDED OPERATING CONDITIONS

SYMBOL	PARAMETER	CONDITIONS	LIMITS		UNIT
			MIN	MAX	
V <sub>CC</sub>	DC supply voltage (for max. speed performance)		2.7	3.6	V
V <sub>CC</sub>	DC supply voltage (for low-voltage applications)		1.2	3.6	V
V <sub>I</sub>	DC Input voltage range	Data inputs only	0	V <sub>CC</sub>	V
V <sub>I</sub>	DC Input voltage range	Control pins only	0	5.5	V
V <sub>O</sub>	DC output voltage range		0	V <sub>CC</sub>	V
T <sub>amb</sub>	Operating free-air temperature range		-40	+85	°C
t <sub>r</sub> , t <sub>f</sub>	Input rise and fall times	V <sub>CC</sub> = 2.7 to 3.0V V <sub>CC</sub> = 3.0 to 3.6V	0	20 10	ns/V

## DC ELECTRICAL CHARACTERISTICS

SYMBOL	PARAMETER	TEST CONDITIONS	LIMITS			UNIT
			Temp = -40°C to +85°C			
			MIN	TYP <sup>1</sup>	MAX	
V <sub>IH</sub>	HIGH level Input voltage	V <sub>CC</sub> = 1.2V	V <sub>CC</sub>			V
		V <sub>CC</sub> = 2.7 to 3.6V	2.0			
V <sub>IL</sub>	LOW level Input voltage	V <sub>CC</sub> = 1.2V			GND	V
		V <sub>CC</sub> = 2.7 to 3.6V			0.8	
V <sub>OH</sub>	HIGH level output voltage	V <sub>CC</sub> = 2.7V; V <sub>I</sub> = V <sub>IH</sub> or V <sub>IL</sub> ; I <sub>O</sub> = -12mA	V <sub>CC</sub> -0.5			V
		V <sub>CC</sub> = 3.0V; V <sub>I</sub> = V <sub>IH</sub> or V <sub>IL</sub> ; I <sub>O</sub> = -100µA	V <sub>CC</sub> -0.2	V <sub>CC</sub>		
		V <sub>CC</sub> = 3.0V; V <sub>I</sub> = V <sub>IH</sub> or V <sub>IL</sub> ; I <sub>O</sub> = -24mA	V <sub>CC</sub> -1.0			
V <sub>OL</sub>	LOW level output voltage	V <sub>CC</sub> = 2.7V; V <sub>I</sub> = V <sub>IH</sub> or V <sub>IL</sub> ; I <sub>O</sub> = 12mA			0.4	V
		V <sub>CC</sub> = 3.0V; V <sub>I</sub> = V <sub>IH</sub> or V <sub>IL</sub> ; I <sub>O</sub> = 100µA			0.2	
		V <sub>CC</sub> = 3.0V; V <sub>I</sub> = V <sub>IH</sub> or V <sub>IL</sub> ; I <sub>O</sub> = 24mA			0.55	
I <sub>I</sub>	Input leakage current	V <sub>CC</sub> = 3.6V; V <sub>I</sub> = 5.5V or GND	Control pins	± 0.1	± 5	µA
		V <sub>CC</sub> = 3.6V; V <sub>I</sub> = V <sub>CC</sub> or GND	Data input pins <sup>2</sup>	± 0.1	± 5	
I <sub>IHZ</sub> /I <sub>ILZ</sub>	Input current for common I/O pins	V <sub>CC</sub> = 3.6V; V <sub>I</sub> = V <sub>CC</sub> or GND		± 0.1	± 15	µA
I <sub>OZ</sub>	3-State output OFF-state current	V <sub>CC</sub> = 3.6V; V <sub>I</sub> = V <sub>IH</sub> or V <sub>IL</sub> ; V <sub>O</sub> = V <sub>CC</sub> or GND		0.1	± 10	µA
I <sub>CC</sub>	Quiescent supply current	V <sub>CC</sub> = 3.6V; V <sub>I</sub> = V <sub>CC</sub> or GND; I <sub>O</sub> = 0		0.2	40	µA
ΔI <sub>CC</sub>	Additional quiescent supply current per control pin	V <sub>CC</sub> = 2.7V to 3.6V; V <sub>I</sub> = V <sub>CC</sub> - 0.6V; I <sub>O</sub> = 0		5	500	µA
ΔI <sub>CC</sub>	Additional quiescent supply current per data I/O pin	V <sub>CC</sub> = 2.7V to 3.6V; V <sub>I</sub> = V <sub>CC</sub> - 0.6V; I <sub>O</sub> = 0		150	750	µA
I <sub>BHL</sub>	Bushold LOW sustaining current	V <sub>CC</sub> = 3.0V; V <sub>I</sub> = 0.8V <sup>2, 3</sup>	75			µA
I <sub>BHH</sub>	Bushold HIGH sustaining current	V <sub>CC</sub> = 3.0V; V <sub>I</sub> = 2.0V <sup>2, 3</sup>	-75			µA
I <sub>BHLO</sub>	Bushold LOW overdrive current	V <sub>CC</sub> = 3.6V <sup>2, 4</sup>	450			µA
I <sub>BHHO</sub>	Bushold HIGH overdrive current	V <sub>CC</sub> = 3.6V <sup>2, 4</sup>	-450			µA

## NOTES:

- All typical values are at V<sub>CC</sub> = 3.3V and T<sub>amb</sub> = 25°C.
- For data inputs only, control inputs do not have a bushold circuit.
- The specified sustaining current at the data input holds the input below the specified V<sub>I</sub> level.
- The specified overdrive current at the data input forces the data input to the opposite logic input state.

## 16-bit buffer/line driver; (3-State)

74LVCH16241

**AC CHARACTERISTICS**GND = 0V;  $t_{\text{R}} = t_{\text{F}} = 2.5\text{ns}$ ;  $C_{\text{L}} = 50\text{pF}$ ;  $R_{\text{L}} = 500\Omega$ ;  $T_{\text{amb}} = -40^{\circ}\text{C}$  to  $+85^{\circ}\text{C}$ .

SYMBOL	PARAMETER	WAVEFORM	LIMITS				UNIT
			$V_{\text{CC}} = 3.3\text{V} \pm 0.3\text{V}$			$V_{\text{CC}} = 2.7\text{V}$	
			MIN	TYP <sup>1</sup>	MAX	MAX	
$t_{\text{PHL}}$ $t_{\text{PLH}}$	Propagation delay nAn to nYn; nAn to nYn	1, 4		2.8	5.0	6.0	ns
$t_{\text{PZH}}$ $t_{\text{PZL}}$	3-State output enable time 1OE to 1Yn; 4OE to 4Yn	2, 4		3.4	6.0	7.0	ns
$t_{\text{PHZ}}$ $t_{\text{PLZ}}$	3-State output disable time 1OE to 1Yn; 4OE to 4Yn	2, 4		3.2	5.5	6.0	ns
$t_{\text{PZH}}$ $t_{\text{PZL}}$	3-State output enable time 2OE to 2Yn; 3OE to 3Yn	3, 4		3.4	6.0	7.0	ns
$t_{\text{PHZ}}$ $t_{\text{PLZ}}$	3-State output disable time 2OE to 2Yn; 3OE to 3Yn	3, 4		3.2	5.5	6.0	ns

**NOTE:**1. All typical values are at  $V_{\text{CC}} = 3.3\text{V}$  and  $T_{\text{amb}} = 25^{\circ}\text{C}$ .

# 16-bit buffer/line driver; (3-State)

# 74LVCH16241

## AC WAVEFORMS

$V_M = 1.5V$  at  $V_{CC} \geq 2.7V$ ;  $V_M = 0.5 V_{CC}$  at  $V_{CC} < 2.7V$ .  
 $V_{OL}$  and  $V_{OH}$  are the typical output voltage drop that occur with the output load.  
 $V_X = V_{OL} + 0.3V$  at  $V_{CC} \geq 2.7V$ ;  $V_X = V_{OL} + 0.1 V_{CC}$  at  $V_{CC} < 2.7V$   
 $V_Y = V_{OH} - 0.3V$  at  $V_{CC} \geq 2.7V$ ;  $V_Y = V_{OH} - 0.1 V_{CC}$  at  $V_{CC} < 2.7V$

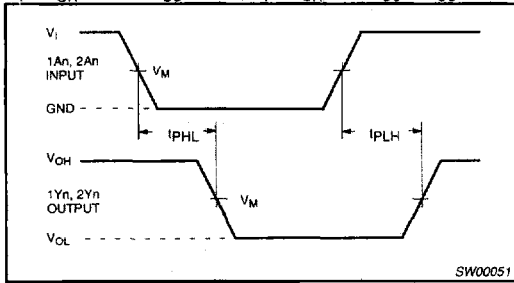

**Waveform 1.** Waveforms showing the input (nAn) to output (nYn) propagation times

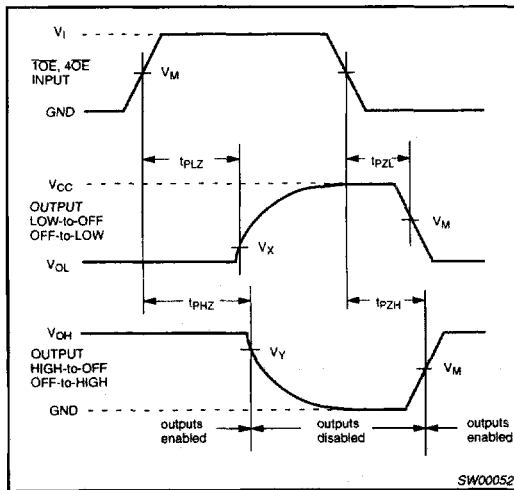

**Waveform 2.** Waveforms showing the 3-State enable and disable times for the input (10E, 40E)

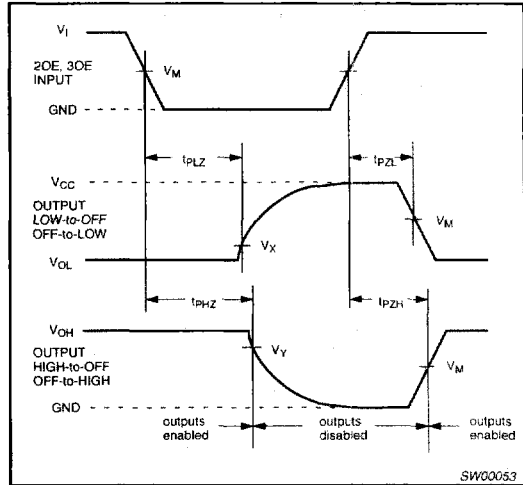

**Waveform 3.** Waveforms showing the 3-State enable and disable times for the input (20E, 30E)

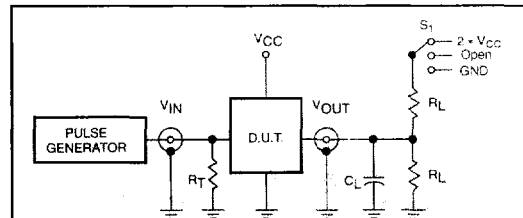

**Test Circuit for 3-State Outputs**

### SWITCH POSITION

TEST	SWITCH
$t_{PLH}/t_{PHL}$	Open
$t_{PLZ}/t_{PZL}$	$2 \cdot V_{CC}$
$t_{PHZ}/t_{PZH}$	GND

$V_{CC}$	$V_I$
$< 2.7V$	$V_{CC}$
$2.7 - 3.6V$	$2.7V$

### DEFINITIONS

$R_L$  = Load resistor; see AC CHARACTERISTICS for value.  
 $C_L$  = Load capacitance includes jig and probe capacitance; see AC CHARACTERISTICS for value.  
 $R_T$  = Termination resistance should be equal to  $Z_{OUT}$  of pulse generators.

SW00047

**Waveform 4.** Load circuitry for switching times