

GD54/74HC157, GD54/74HCT157 QUAD 2-INPUT SELECTORS/MULTIPLEXERS WITH NONINVERTED OUTPUT

General Description

These devices are identical in pinout to the 54/74LS157. They consist of four 2-input multiplexers with common select and enable inputs, and noninverted outputs. When the enable input is low, the four outputs assume the value as selected from the inputs, when the enable input is high, the output become low regardless of any other inputs values. Select decoding is done internally resulting in a single select input only. The HC/HCT 158 operates in the same manner, except that its outputs are in inverted form. The HC/HCT 157 is similar in function to the HC/HCT 257 and 258 which have 3-state outputs. These devices are characterized for operation over wide temperature ranges to meet industry and military specifications.

Features

- Low Power consumption characteristic of CMOS devices
- Output drive capability: 10 LS TTL Loads Min.
- Operating speed superior to LS TTL
- Wide operating voltage range: for HC 2 to 6 volts
for HCT 4.5 to 5.5 volts
- Low input current: 1 μ A Max.
- Low quiescent current: 80 μ A Max. (74HC)
- High noise immunity characteristic of CMOS
- Diode protection on all inputs

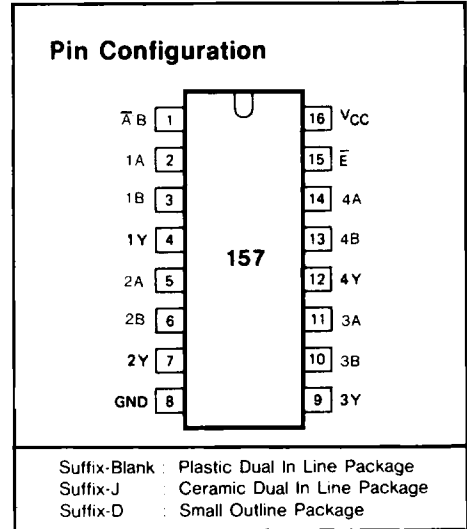

Function Table

INPUTS				OUTPUT
\bar{E}	\bar{A}/B	nA	nB	nY
H	X	X	X	L
L	L	L	X	L
L	L	H	X	H
L	H	X	L	L
L	H	X	H	H

H=HIGH voltage level
 L=LOW voltage level
 X=don't care

Absolute Maximum Ratings

SYMBOL	PARAMETER	CONDITIONS	MIN.	MAX.	UNIT
V_{CC}	DC Supply voltage		-0.5	+7	V
I_{IK}, I_{OK}	DC input or output diode current	for $V_I < -0.5$ or $V_I > V_{CC} + 0.5V$		20	mA
I_O	DC output source or sink current	for $-0.5V < V_O < V_{CC} + 0.5V$		25	mA
I_{CC}	DC V_{CC} or GND current			50	mA
T_{stg}	Storage temperature range		-65	150	°C
P_D	Power dissipation per package	above +70°C derate linearly with 8mW/K		500	mW
T_L	Lead temperature	At distance 1/16 ± 1/32 in. from case for 60 sec(CERAMIC) 10 sec(PLASTIC)		300 260	°C

Recommended Operating Conditions

CHARACTERISTIC	LIMITS		UNITS
	MIN	MAX	
Supply-Voltage Range V_{CC} : GD54/74HC Types GD54/74HCT Types	2 4.5	6 5.5	V
DC Input or Output Voltage V_I, V_O	0	V_{CC}	V
Operating Temperature T_A : GD74 Types GD54 Types	-40 -55	+85 +125	°C
Input Rise and Fall times t_r, t_f : GD54/74HC Types at 2V at 4.5V at 6V GD54/74HCT Types at 4.5V		1000 500 400 500	ns

Logic Diagram

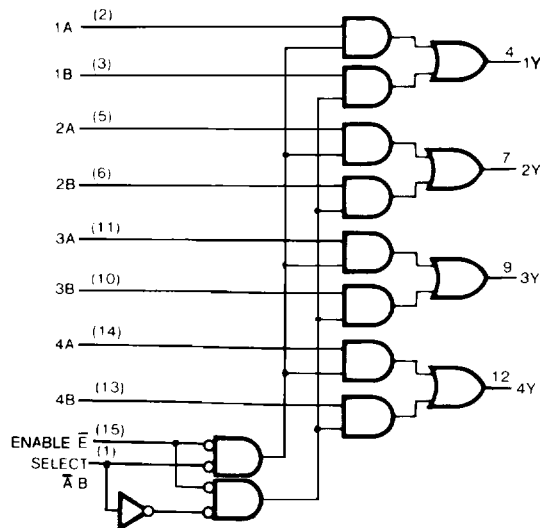

Fig. 1 Logic diagram

GD54/74HC157, GD54/74HCT157

DC Electrical Characteristics for HC

SYMBOL	PARAMETER	TEST CONDITION	V _{CC} (V)	T _A =25°C			GD74HC157		GD54HC157		UNIT	
				MIN.	TYP.	MAX.	MIN.	MAX.	MIN.	MAX.		
V _{IH}	HIGH level input Voltage		2.0	1.5			1.5		1.5		V	
			4.5	3.15			3.15		3.15			
			6.0	4.2			4.2		4.2			
V _{IL}	LOW level input voltage		2.0			0.3		0.3		0.3	V	
			4.5			0.9		0.9		0.9		
			6.0			1.2		1.2		1.2		
V _{OH}	HIGH level output voltage	V _{IN} =V _{IH}	I _{OH} =-20μA	2.0	1.9	2.0		1.9		1.9	V	
				4.5	4.4	4.5		4.4		4.4		
				6.0	5.9	6.0		5.9		5.9		
		or V _{IL}	I _{OH} =-4mA	4.5	3.98	4.3		3.84		3.7		
				6.0	5.48	5.2		5.34		5.2		
V _{OL}	LOW level output voltage	V _{IN} =V _{IH}	I _{OL} =20μA	2.0			0.1		0.1	V		
				4.5			0.1		0.1			
				6.0			0.1		0.1			
		or V _{IL}	I _{OL} =4mA	4.5		0.17	0.26		0.33			0.4
				6.0		0.15	0.26		0.33			0.4
I _{IH}	Input leakage Current	V _{IN} =V _{CC} or GND	6.0			0.1		1.0		1.0	μA	
I _{CC}	Quiescent Supply Current	V _{IN} =V _{CC} or GND I _{out} =0μA	6.0			8		80		160	μA	

DC Electrical Characteristics for HCT

SYMBOL	PARAMETER	TEST CONDITION	V _{CC} (V)	T _A =25°C			GD74HCT157		GD54HCT157		UNIT	
				MIN.	TYP.	MAX.	MIN.	MAX.	MIN.	MAX.		
V _{IH}	HIGH level input Voltage		4.5 to 5.5	2.0			2.0		2.0		V	
V _{IL}	LOW level input voltage		4.5 to 5.5			0.8		0.8		0.8	V	
V _{OH}	HIGH level output voltage	V _{IN} =V _{IH}	I _{OH} =-20μA	4.5	4.4	4.5		4.4		4.4	V	
				4.5	3.98	4.3		3.84		3.7		
				6.0								
		or V _{IL}	I _{OH} =-4mA	4.5	3.98	4.3		3.84		3.7		
				6.0								
V _{OL}	LOW level output voltage	V _{IN} =V _{IH}	I _{OL} =20μA	4.5			0.1		0.1	V		
				4.5			0.1		0.1			
				6.0			0.1		0.1			
		or V _{IL}	I _{OL} =4mA	4.5		0.17	0.26		0.33			0.4
				6.0								
I _{IH}	Input leakage Current	V _{IN} =V _{CC} or GND	5.5			0.1		1.0		1.0	μA	
I _{CC}	Quiescent Supply Current	V _{IN} =V _{CC} or GND I _{out} =0μA	5.5			8		80		160	μA	

GD54/74HC157, GD54/74HCT157

AC Characteristics for HC: $t_r=t_f=6\text{ns}$ $C_L=50\text{ pF}$

SYMBOL	PARAMETER V_{CC}	V_{CC} (V)	$T_A=25^\circ\text{C}$			GD74HC157		GD54HC157		UNIT
			MIN.	TYP.	MAX.	MIN.	MAX.	MIN.	MAX.	
$t_{PLH}/$ t_{PHL}	Propagation Delay Time	2.0		36	125		155		190	ns
	nA, nB to nY	4.5		13	25		31		38	
		6.0		10	21		26		32	
$t_{PLH}/$ t_{PHL}	Propagation Delay Time	2.0		39	115		145		175	ns
	E to nY	4.5		14	23		29		35	
		6.0		11	20		25		30	
$t_{PLH}/$ t_{PHL}	Propagation Delay Time	2.0		47	145		180		220	ns
	Select \bar{A}/B to nY	4.5		17	29		36		44	
		6.0		14	25		31		38	
$t_{TLH}/$ t_{THL}	Output Transition Time	2.0		19	75		95		110	ns
		4.5		7	15		19		22	
		6.0		6	13		16		19	

AC Characteristics for HCT: $t_r=t_f=6\text{ns}$ $C_L=50\text{ pF}$

SYMBOL	PARAMETER	V_{CC} (V)	$T_A=25^\circ\text{C}$			GD74HCT157		GD54HCT157		UNIT
			MIN.	TYP.	MAX.	MIN.	MAX.	MIN.	MAX.	
$t_{PLH}/$ t_{PHL}	Propagation Delay Time	4.5		16	27		34		41	ns
	nA, nB to nY									
$t_{PLH}/$ t_{PHL}	Propagation Delay Time	4.5		15	26		33		39	ns
	\bar{E} to nY									
$t_{PLH}/$ t_{PHL}	Propagation Delay Time	4.5		22	37		46		56	ns
	Select \bar{A}/B to nY									
$t_{TLH}/$ t_{THL}	Output Transition Time	4.5		7	15		19		22	ns

AC Waveforms

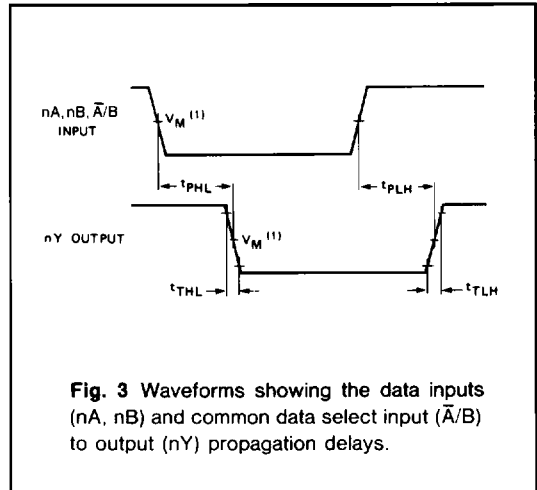
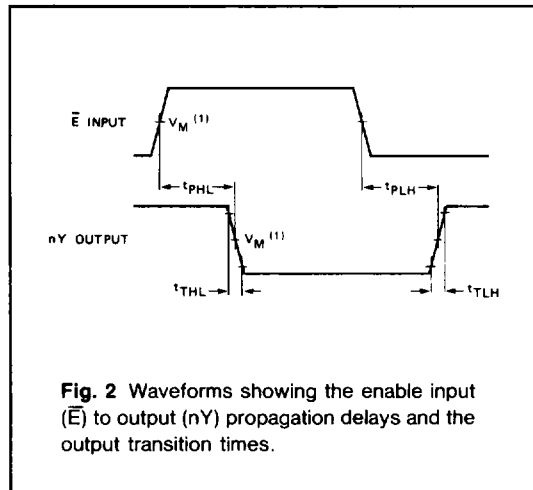

Note to AC waveforms

(1) HC : $V_M=50\%$; $V_I=GND$ to V_{CC}

HCT: $V_M=1.3V$; $V_I=GND$ to $3V$.