

54LS240, 54LS241, 54S240, 54S241 Buffers

Military Logic Products

'240 Octal Inverter Buffer (3-State)
'241 Octal Buffer (3-State)
Product Specification

FUNCTION TABLE '240

INPUTS				OUTPUTS	
OE _a	I _a	OE _b	I _b	Y _a	Y _b
L	L	L	L	H	H
L	H	L	H	L	L
H	X	H	X	(Z)	(Z)

H = High voltage level
L = Low voltage level
X = Don't care
(Z) = High impedance (off) state

FUNCTION TABLE '241

INPUTS				OUTPUTS	
OE _a	I _a	OE _b	I _b	Y _a	Y _b
L	L	H	L	L	L
L	H	H	H	H	H
H	X	L	X	(Z)	(Z)

H = High voltage level
L = Low voltage level
X = Don't care
(Z) = High impedance (off) state

ORDERING INFORMATION

DESCRIPTION	ORDER CODE
20-Pin Ceramic DIP	54LS240/BRA 54S240/BRA 54LS241/BRA 54S241/BRA
20-Pin Ceramic FlatPack	54LS240/BSA 54S240/BSA 54LS241/BSA 54S241/BSA
20-Pin Ceramic LLCC	54LS240/B2A 54S240/B2A 54LS241/B2A 54S241/B2A

INPUT AND OUTPUT LOADING AND FAN-OUT TABLE

PINS	DESCRIPTION	54S	54LS
I _{a0} - I _{a3} , I _{b0} - I _{b3}	Inputs	1SUL	1LSUL
OE _a , OE _b , OE _c	Inputs	1SUL	1LSUL
All	Outputs	24SUL	32LSUL

NOTE: A 54S Unit Load (SUL) is 50μA I_{IH}, and -2.0mA I_{IL}, and a 54LS Unit Load (LSUL) is 20μA I_{IH} and -0.4mA I_{IL}.

PIN CONFIGURATION

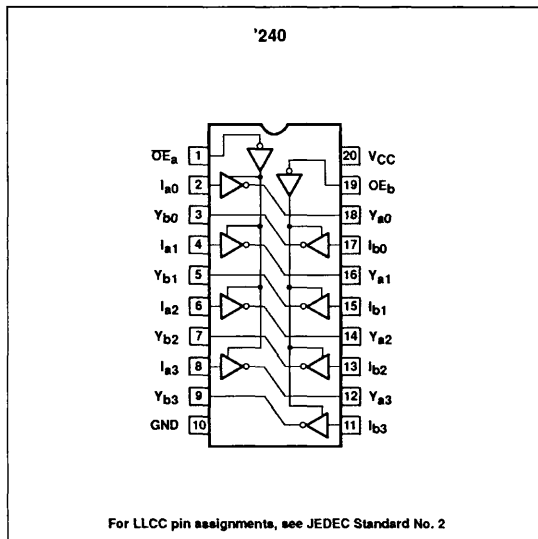

LOGIC SYMBOL

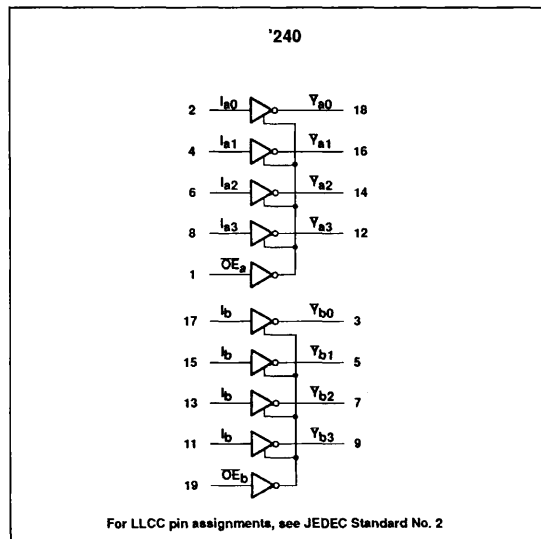

Buffers

54LS240, 54LS241, 54S240, 54S241

PIN CONFIGURATION

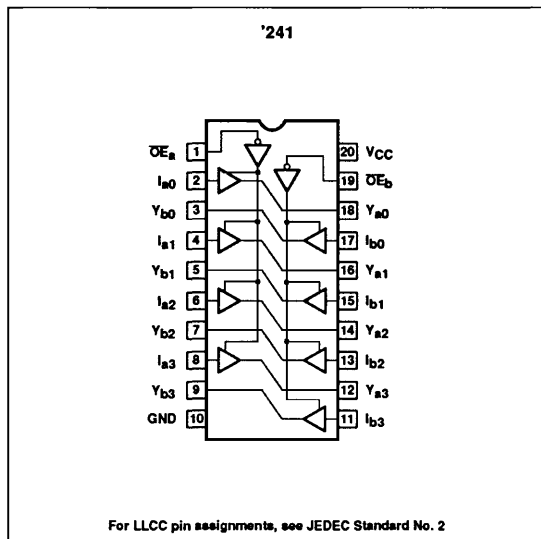

LOGIC SYMBOL

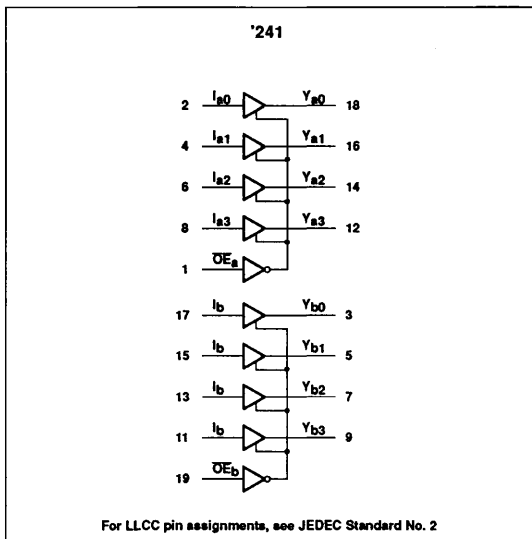

ABSOLUTE MAXIMUM RATINGS (Over operating free-air temperature range unless otherwise noted.)

SYMBOL	PARAMETER	54LS	54S	UNIT
V _{CC}	Supply voltage	7.0	7.0	V
V _I	Input voltage range	-0.5 to +7.0	-0.5 to +5.5	V
I _I	Input current range	-30 to +1	-30 to +5	mA
V _O	Voltage applied to output in High output state range	-0.5 to +V _{CC}	-0.5 to +V _{CC}	V
T _{STG}	Storage temperature range	-65 to +150	-65 to +150	°C

RECOMMENDED OPERATING CONDITIONS

SYMBOL	PARAMETER	54LS			54S			UNIT
		Min	Nom	Max	Min	Nom	Max	
V _{CC}	Supply voltage	4.5	5.0	5.5	4.5	5.0	5.5	V
V _{IH}	High-level input voltage	2.0			2.0			V
V _{IL}	Low-level input voltage			+0.7			+0.8	V
		+125°C		+0.7			+0.7	V
I _{IK}	Input clamp current			-18			-18	mA
I _{OH}	High-level output current			-12			-12	mA
I _{OL}	Low-level output current			12			48	mA
T _A	Operating free-air temperature range	-55		+125	-55		+125	°C

Buffers

54LS240, 54LS241, 54S240, 54S241

DC ELECTRICAL CHARACTERISTICS (Over recommended operating free-air temperature range unless otherwise noted.)

SYMBOL	PARAMETER	TEST CONDITIONS ¹	54LS240, 241			54S240, 241			UNIT		
			Min	Typ ²	Max	Min	Typ ²	Max			
ΔV_T	Hysteresis ($V_{T+} - V_{T-}$) ⁶	$V_{CC} = \text{Min}$	0.2	0.4		0.2	0.4		V		
V_{OH}	High-level output voltage	$V_{CC} = \text{Min}, V_{IH} = \text{Min}, V_{IL} = \text{Max}, I_{OH} = \text{Max}$	2.0			2.0			V		
		$V_{CC} = \text{Min}, V_{IH} = \text{Min}, V_{IL} = \text{Max}, I_{OH} = -3\text{mA}$	2.4	3.4		2.4	3.4		V		
V_{OL}	Low-level output voltage	$V_{CC} = \text{Min}, V_{IH} = \text{Min}, V_{IL} = \text{Max}, I_{OL} = \text{Max}$			0.4			0.55	V		
V_{IK}	Input clamp voltage	$V_{CC} = \text{Min}, I_I = I_{IK}$			-1.5			-1.2	V		
I_{OZH}	Offstate output current, High-level voltage applied	$V_{CC} = \text{Max}, V_{IH} = \text{Min}, V_{IL} = \text{Max}$	$V_O = 2.4\text{V}$					50	μA		
			$V_O = 2.7\text{V}$			20			μA		
I_{OZL}	Offstate output current, Low-level voltage applied	$V_{CC} = \text{Max}, V_{IH} = \text{Min}, V_{IL} = \text{Max}$	$V_O = 2.4\text{V}$			-20			μA		
			$V_O = 0.5\text{V}$					-50	μA		
I_{IH2}	Input current at maximum input voltage	$V_{CC} = \text{Max}$	$V_I = 5.5\text{V}$					1.0	mA		
			$V_I = 7.0\text{V}$			0.1			mA		
I_{IH1}	High-level input current	$V_{CC} = \text{Max}, V_I = 2.7\text{V}$			20			50	μA		
I_{IL}	Low-level input current	$V_{CC} = \text{Max}$	$V_I = 0.4\text{V}$			-0.2			mA		
			$V_I = 0.5\text{V}$	$I_{A0} - I_{A3}, I_{B0} - I_{B3}$ inputs					-400	μA	
				OE_a, OE_b, OE_b inputs						-2	mA
I_{OS}	Short-circuit output current ³	$V_{CC} = \text{Max}$	-40		-130	-80		-180	mA		
I_{CC}	Supply current ⁴ (total)	$V_{CC} = \text{Max}$	I_{CCH}	'LS240		17	27			mA	
					I_{CCL}		26	44			mA
					I_{CCZ}		29	60			mA
			I_{CCH}	'LS241		17	27			mA	
					I_{CCL}		27	46			mA
					I_{CCZ}		32	54			mA
			I_{CCH}	'S240				80	123	mA	
					I_{CCL}			100	145	mA	
					I_{CCZ}			100	145	mA	
			I_{CCH}	'S241				95	147	mA	
					I_{CCL}			120	170	mA	
					I_{CCZ}			120	170	mA	

Buffers**54LS240, 54LS241, 54S240, 54S241****AC ELECTRICAL CHARACTERISTICS** $T_A = 25^\circ\text{C}$, $V_{CC} = 5.0\text{V}$

SYMBOL	PARAMETER	TEST CONDITIONS	54LS		54S		UNIT
			$C_L = 50\text{pF}$		$C_L = 50\text{pF}$		
			Min	Max	Min	Max	
t_{PLH} t_{PHL}	Propagation delay	Waveform 1, '240		14 18		7 7	ns ns
t_{PLH} t_{PHL}	Propagation delay	Waveform 2, '241		18 18		9 9	ns ns
t_{PZH}	Enable to High	Waveform 3	LS	30			ns
			'S240			10	ns
			'S241			12	ns
t_{PZL}	Enable to Low	Waveform 4		30		15	ns
t_{PHZ}	Disable from High	Waveform 3, $C_L = 5\text{pF}^5$		18		9	ns
t_{PLZ}	Disable from Low	Waveform 4, $C_L = 5\text{pF}^5$		25		15	ns
t_{PHZ}	Disable from High	Waveform 3, $C_L = 50\text{pF}$		34		14	ns
t_{PLZ}	Disable from Low	Waveform 4, $C_L = 50\text{pF}$		27		16.5	ns

AC ELECTRICAL CHARACTERISTICS $T_A = -55^\circ\text{C}$ and $+125^\circ\text{C}$, $V_{CC} = 5.0\text{V}^6$

SYMBOL	PARAMETER	TEST CONDITIONS	54LS		54S		UNIT
			$C_L = 50\text{pF}$		$C_L = 50\text{pF}$		
			Min	Max	Min	Max	
t_{PLH} t_{PHL}	Propagation delay	Waveform 1, '240		18 23		9.0 9.0	ns ns
t_{PLH} t_{PHL}	Propagation delay	Waveform 2, '241		23 23		16 12	ns ns
t_{PZH}	Enable to High	Waveform 3	LS	39			ns
			'S240			13	ns
			'S241			20	ns
t_{PZL}	Enable to Low	Waveform 4		39		20	ns
t_{PHZ}	Disable from High	Waveform 3, $C_L = 5\text{pF}^5$		23		12	ns
t_{PLZ}	Disable from Low	Waveform 4, $C_L = 5\text{pF}^5$		33		20	ns
t_{PHZ}	Disable from High	Waveform 3, $C_L = 50\text{pF}$		44		18	ns
t_{PLZ}	Disable from Low	Waveform 4, $C_L = 50\text{pF}$		35		22	ns

NOTES:

- For conditions shown as Min or Max, use the appropriate value specified under recommended operating conditions for the applicable type and function table operating mode.
- All typical values are at $V_{CC} = 5\text{V}$, $T_A = 25^\circ\text{C}$.
- Not more than one output should be shorted at a time and duration of the short circuit should not exceed one second.
- I_{CC} is measured with outputs open.
- Guaranteed by 50pF limits, but not tested.
- These parameters are guaranteed, but not tested.

Buffers

54LS240, 54LS241, 54S240, 54S241

AC WAVEFORMS

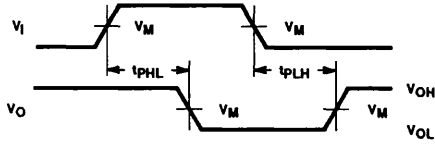

Waveform 1. Waveform for Inverting Outputs

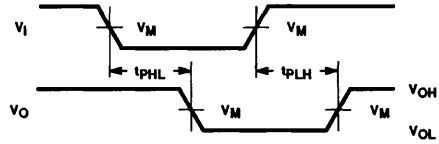

Waveform 2. Waveform for Non-Inverting Outputs

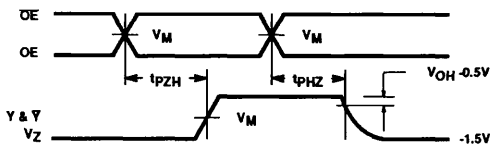

Waveform 3. 3-State Enable Time to High Level and Disable Time from High Level

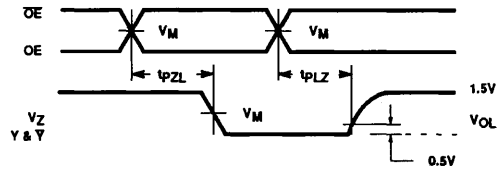

Waveform 4. 3-State Enable Time to Low Level and Disable Time from Low Level

FAMILY	V_M	V_{MZL}	V_{MZH}	V_Z
54LSXXX	1.3V	0.7V	1.9V	1.45V
54SXXX	1.5V	0.7V	2.0V	1.65V

Buffers

54LS240, 54LS241, 54S240, 54S241

TEST CIRCUIT AND WAVEFORM

